



5Amp/75Volt/100-Watt Load

- * Remote sense Loads for accurate voltage measurement of the DUT
- * Loads can be operated in parallel for power applications up to 500 watts
- * Programmable slew rate
- * Load synchronisation capabilities
- * Operation in constant current, constant voltage, constant resistance and constant power modes



The 100W DC Load module is designed for use in an Intepro 9000 test system. The unit is 261mm (6U) high, approximately 390mm deep, and fits into a 19-inch rack.

Features of the 100W DC Load include:

- ? Surface-mount and through-hole technology
- ? High slew rate performance
- ? 1kV isolation
- ? Analog to digital converter for measurement of voltage and current to 15-bit resolution

100 Watt DC Load

System Implementation

In an Intepro 9000 System, the Loads are controlled via a Controller Module (20mm /4HP wide) that is used to communicate with the host PC over an IEEE link. The Controller Module relays commands and information over the internal CAN bus to the Loads.

Each Load in a rack system can be addressed individually, as each back plane PCB slot has a unique address.

The sense voltage from each Load can be daisy chained via RJ45 connectors and connected to a high speed Measurement Module which performs transient, peak, counting, timing, ripple and noise, DC, and AC tests on the DUT.

Each slot in a rack has a unique address read by the load on power up. Each rack in a system has a unique rack address set by the user with DIL switches. These two addresses combine to give the load a unique CAN ID in the system.

Intepro engineers designed the 100W DC Load to enable high slew rate performance and efficient operation of constant voltage. This DC Load also boasts high resolution and improved current accuracy due to a lower current range.

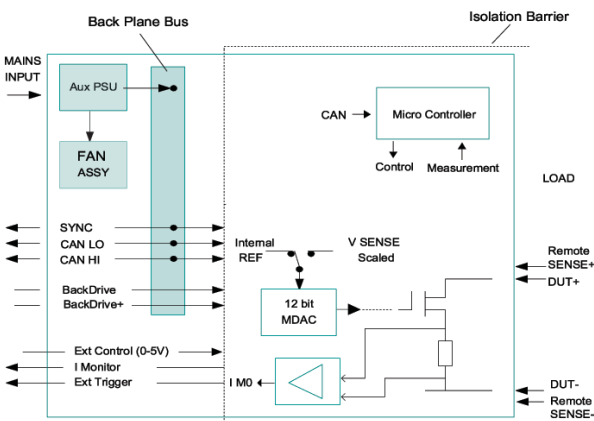

Figure 1: System Load Block Diagram