

INTEPRO

SYSTEMS

Programming Guide

ModBus & SCPI

For USB, GPIB, Ethernet
and AnyBus modules



Attention! This document is only valid for the device series listed in section 1.1.2 and also only valid as from the firmware version listed there.

Doc ID: PGMBEN
Revision: 17
Date: 09-18-2019

TABLE OF CONTENTS

1. GENERAL	5
1.1 About this document.....	5
1.1.1 Copyright.....	5
1.1.2 Validity.....	5
1.2 Explanation of symbols	5
1.3 Warranty.....	5
1.4 Limitation of liability	6
2. ANYBUS MODULES	7
2.1 Overview	7
2.2 Anybus module support.....	8
2.3 Before you begin	8
2.4 Installation of an Anybus module.....	8
2.5 Network with linear topology	8
2.6 Network access via HTTP.....	9
2.7 Network access via TCP	9
3. INTRODUCTION	10
3.1 Communication with a device in general.....	10
3.2 Control locations.....	10
3.3 Message timing and command execution time	10
3.3.1 Execution time when writing.....	10
3.3.2 Response time when reading.....	11
3.3.3 Timing of messages	12
3.4 Overview of the communication protocols.....	13
3.5 Special characteristics of remote control.....	14
3.6 Fragmented messages on serial transmissions	14
3.7 Connection timeout	14
3.8 Effective resolution when programming	14
3.9 Minimum slope (function generator).....	15
4. THE MODBUS PROTOCOL	16
4.1 General information about ModBus RTU	16
4.2 General information about ModBus TCP	16
4.3 Format of set values and resolution	16
4.4 Translating set values and actual values	16
4.5 Communication with the device via AnyBus modules	17
4.5.1 Ethernet.....	17
4.5.2 Profinet / Profibus.....	17
4.5.3 CANopen.....	17
4.5.4 CAN.....	17
4.5.5 ModBus TCP.....	17
4.5.6 EtherCAT.....	17
4.6 Communication with the device via USB port	17
4.6.1 USB driver installation.....	17
4.6.2 First steps.....	17
4.7 About the register lists.....	18
4.7.1 Columns "Function".....	18
4.7.2 Column "Data type"	18
4.7.3 Column "Access".....	18
4.7.4 Column "Number of registers".....	18
4.7.5 Column "Data".....	18
4.7.6 Columns "Profibus/Profinet slot & index"	18
4.7.7 Column "EtherCAT SDO/PDO?"	18

4.8	ModBus RTU in detail	19
4.8.1	Message types	19
4.8.2	General	19
4.8.3	Functions.....	19
4.8.4	Control messages (write)	20
4.8.5	Query message.....	20
4.8.6	Response message (read).....	21
4.8.7	The ModBus checksum.....	21
4.8.8	Communication errors.....	22
4.8.9	Examples of ModBus RTU messages	23
4.9	ModBus TCP in detail.....	25
4.9.1	Example for a ModBus TCP message	25
4.10	Explanation about specific registers.....	26
4.10.1	Register 171.....	26
4.10.2	Register 411	26
4.10.3	Registers 500-503 (Set values).....	26
4.10.4	Register 505 (Device status).....	26
4.10.5	Registers 650 - 662 (Master-slave configuration)	27
4.10.6	Registers 850 - 6695 (Function generator)	27
4.10.7	Registers 850 - 1692 (Sequence generator).....	30
4.10.8	Registers 850 - 854 and 900 - 908 (Function generator EL 3000 B)	30
4.10.9	Registers 9000 - 9009 (Adjustment limits)	31
4.10.10	Registers 10007 - 10900.....	31
4.10.11	Registers from 11000 (MPP tracking feature)	31
4.10.12	Registers from 11500 (battery test).....	32
4.10.13	Register from 12000 (advanced photovoltaics simulation acc. DIN EN 50530).....	33

5. SCPI PROTOCOL 35

5.1	Format of set values and actual values.....	35
5.2	Syntax	35
5.2.1	Coupled commands	35
5.2.2	Upper and lower case	36
5.2.3	Long form and short form.....	36
5.2.4	Termination character.....	36
5.2.5	Errors	36
5.3	Examples for a first start.....	37
5.3.1	Ping.....	37
5.3.2	Switch to remote control or back to manual control	37
5.4	Command groups.....	38
5.4.1	Standard IEEE commands.....	38
5.4.2	Status registers	39
5.4.3	Set value commands.....	42
5.4.4	Measuring commands.....	45
5.4.5	Status commands	46
5.4.6	Commands for protective features	48
5.4.7	Commands for supervision features	49
5.4.8	Commands for adjustment limits.....	51
5.4.9	Commands for master-slave operation	52
5.4.10	Commands for general queries.....	53
5.4.11	Commands for device configuration.....	54
5.4.12	Commands for remote control of the function generator.....	61
5.4.13	Commands for remote control of the sequence generator.....	67
5.4.14	Commands for remote control of the MPP tracking feature	69
5.4.15	Commands for alarm management.....	71
5.4.16	Commands for presets (Recall)	72
5.4.17	Commands for the extended PV simulation.....	74
5.4.18	Commands for the battery test function	79

5.5	Example applications	82
5.5.1	Configure and control master-slave with SCPI	82
5.5.2	Programming examples for the function generator	83
5.5.3	Programming examples for PV simulation (DIN EN 50530)	87
5.5.4	Programming examples for MPP tracking.....	91
6.	PROFIBUS & PROFINET	94
6.1	General.....	94
6.2	Preparation.....	94
6.3	Slot configuration for Profibus	94
6.4	Slot configuration for Profinet.....	95
6.5	Cyclic communication via Profibus/Profinet	95
6.6	Acyclic communication via Profibus/Profinet.....	96
6.7	Examples for acyclic access	97
6.7.1	Activate/deactivate remote control	97
6.7.2	Send a set value	97
6.7.3	Read something	98
6.8	Data interpretation.....	98
7.	CANOPEN	99
7.1	Preparation.....	99
7.2	User objects (indexes).....	99
7.2.1	Translation ADI -> register	99
7.3	Specific examples	99
7.4	CANopen to ModBus differences	100
7.4.1	When using the arbitrary generator.....	100
7.5	Error codes.....	100
8.	CAN	101
8.1	Preparation.....	101
8.2	Introduction.....	101
8.3	Message formats.....	101
8.3.1	Normal sending (writing)	101
8.3.2	Cyclic sending (writing)	102
8.3.3	Querying.....	103
8.3.4	Normal reading.....	103
8.3.5	Cyclic reading.....	104
8.3.6	Message examples	106
9.	ETHERCAT	107
9.1	Preamble.....	107
9.2	Integrating your device in TwinCAT	107
9.3	Data objects	107
9.3.1	PDO object.....	108
9.3.2	SDOs.....	108
9.3.3	Use of the data objects	108
A.	APPENDIX	109
A1.	Device classes	109

1. General

1.1 About this document

1.1.1 Copyright

Reprinting, copying, also partially, usage for other purposes as foreseen of this manual are forbidden and breach may lead to legal process.



1.1.2 Validity

This manual is valid for the below listed equipment including derived variants. This programming guide is connected to the firmware version of the communication unit KE. Older KE firmwares can thus be partially incompatible with this document. **It's recommended to memorize the abbreviation from the table below. It's later used as reference to determine whether a specific command or feature is supported by your device.**

Series	Firmware from	Abbr.
EL 3000 B	KE: 2.02	EL3
EL 9000 B 3U - 24A / HP / 2Q	KE: 2.27 (standard) / KE: 2.09 (GPIB)	ELR9
EL 9000 B Slave	KE: 2.27	ELR9
EL 9000 DT / EL 9000 T	KE: 3.06	DT
ELR/ELM 5000	HMI: 2.03	ELR5
ELR 9000 / ELR 9000 HP	KE: 2.27 (standard) / KE: 2.09 (GPIB)	ELR9
ELR 10000	KE: 2.01	ELR9
PS 5000	KE: 2.02	PS5
PSI 5000	KE: 3.06	PSI5
PS 9000 1U/2U/3U (series from 2014)	KE: 3.06	PS9
PS 9000 T	KE: 3.06	PST
PSB 9000	KE: 2.27	PSB
PSB 10000	KE: 2.01	PSB
PSBE 9000	KE: 2.27	PSBE
PSE 9000	KE: 2.27	PSE
PSI 9000 2U / 3U / WR / SLAVE (series from 2014)	KE: 2.27 (standard) / KE: 2.09 (GPIB)	PSI9
PSI 9000 15U / 24U	KE: 2.27	PSI9
PSI 9000 DT	KE: 3.06	DT
PSI 9000 T	KE: 3.06	PSIT
PSI 10000	KE: 2.01	PSI9
PS 3000 C	KE: 2.02	PS3

1.2 Explanation of symbols

Warning and safety notices as well as general notices in this document are shown in a box with a symbol as follows:

	Symbol for general safety notices (instructions and damage protection bans)
	Symbol for general notices

1.3 Warranty

The manufacturer guarantees the functional competence of the applied technology and the stated performance parameters. The warranty period begins with the delivery of free from defects equipment.

Terms of guarantee are included in the general terms and conditions of the manufacturer.

1.4 Limitation of liability









All statements and instructions in this manual are based on current norms and regulations, up-to-date technology and our long term knowledge and experience. The manufacturer accepts no liability for losses due to:

- Usage for purposes other than designed
- Use by untrained personnel
- Modification of devices by the customer
- Technical changes of devices
- Use of not authorized spare parts



ModBus & SCPI

2. Anybus modules

2.1 Overview

Module	Type / Connectors	LED indication	Front view	
IF-AB-CAN	CAN 2.0B, 1x Sub-D 9pole, male	RUN	Indicates data traffic (green, flickering)	
		ERR		
IF-AB-CANO	CANopen, 1x Sub-D 9pole, male	RUN	Indicates status with flash sequences according to DR303-3 (CiA)	
		ERR		
IF-AB-RS232	RS 232, 1x Sub-D 9pole, male, for null modem cable	PWR	Module is powered	
IF-AB-PBUS	Profibus DP-V1 Slave, 1x Sub-D 9pole, female	OP	Operation mode: on (green) = Connection established flashing (green) = Ready flashing (red, 1x) = Parameter error flashing (red, 2x) = Profibus error	
		ST		
IF-AB-ETH1P	Ethernet, 1x RJ45	NS	Network status: flashing (green) = default, can be ignored on (red) = Double IP, fatal error flashing (red) = Connection time-out	
		MS		
IF-AB-ETH2P	Ethernet, 2x RJ45	LINK	Connection status: on (green) = Connection established flashing (green) = Data traffic	
IF-AB-PNET1P	ProfiNET IO, 1x RJ45	NS	Network status: on (green) = Online with controller in RUN flashing (green) = Controller in STOP	
		MS		
IF-AB-PNET2P	ProfiNET IO, 2x RJ45	LINK	Connection status: on (green) = Connection established flashing (green) = Data traffic	
IF-AB-ECT	EtherCAT Slave, 2x RJ45	RUN	Indicates status with flash sequences according to DR303-3 (CiA)	
		ERR		

ModBus & SCPI

Module	Type / Connectors	LED indication		Front view
IF-AB-MBUS1P	ModBus TCP, 1x RJ45	NS	Network status: on (green) = Module active flashing (green) = Module waiting for connection on (red) = Double IP or fatal error flashing (red) = Process time-out	
		MS	Module status: on (green) = Everything OK on (red) = Primary error flashing (red) = Secondary error	
IF-AB-MBUS2P	ModBus TCP, 2x RJ45	LINK	Connection status: on (green) = Connection established flashing (green) = Data traffic	

2.2 Anybus module support

These device series support the in 2.1 listed Anybus modules (date: 09-18-2019):

- ELR 9000 / ELR 9000 HP / ELR 10000
- EL 9000 B / EL 9000 B HP / EL 9000 B 2Q
- PSE 9000
- PSI 9000 2U - 24U
- PSI 10000
- PSB 9000 / PSBE 9000
- PSB 10000



It might be required to install a firmware update for KE" in your device in case the device won't support a specific interface module after installation.

2.3 Before you begin

If you plan to integrate a device into an existing network or field bus with any of these interface installed, notice following:

- All modules, but especially the Ethernet types which provide a web site, require a certain startup time each time the device is powered, which will delay their network readiness. Usually, the interface module is ready for communication as soon as the device is ready for operation.
- The readiness for operation may be indicated by the modules (with one of the LEDs) before the required startup time has run out. If one would try to contact an Ethernet module in order to access the website, the website might not be loaded completely or the browser might stop with a time-out error.

2.4 Installation of an Anybus module

The installation itself is described in the user manual of your device, as well as the required setup. Further information about installation and connection to field buses and networks can be found in publicly available documentation and similar sources.



The CANopen module IF-AB-CANO does not feature an internal termination resistor. Thus the required bus termination resistor has to be applied by the user according to the CAN bus requirements.

2.5 Network with linear topology

The Ethernet based modules for standard LAN, ModBus TCP and Profinet/IO are also available in a version with two ports. These provide the possibility to connect multiple devices in a linear topology and even to build a ring (DLR, device level ring) for extended safety against interruption. External switches can be spared and the many long network cables, like when having a star-shaped topology, can be reduced to a minimum.

The EtherCAT module, however, has two ports by default and always builds a ring because of the standard setup within EtherCAT systems. It's also Ethernet based, but cannot be considered as LAN port.

2.6 Network access via HTTP

The Ethernet based modules, like for standard LAN, ModBus TCP or Profinet, and the integrated LAN ports as features with some series like PS 9000 from 2014 and PSI 5000 offer a **website**. It's accessible with common browsers (Firefox, Chrome, Safari) by simply entering the IP address or the host name which has been assigned to the device. Accessing the website via the host name (default: Client) is only possible if the network runs a DNS or, when using direct connection, the PC runs a DNS and the domain/host name is already registered.

The default IP is **198.168.0.2**. All network parameters for the device/network interface can be changed or reset to defaults in the setup menu of the device (where featured).

The currently active IP address, along with other network related parameters like gateway, DNS address, subnet mask and MAC address, can also be read from an overview in the setup menu of devices where the series features an on-screen setup menu.

The website gives the user full control over the device by manually typing SCPI commands. It primarily serves for simple testing purposes. In case you want to continuously control a device or at least monitor it, please continue reading in section „5. SCPI protocol“ on page 35.

The website, precisely the second page CONFIGURATION, allows for setting up network specific parameters, like when doing it in the device setup menu, and to write them to the device remotely, requiring prior activation of remote control by command SYST:LOCK ON.

2.7 Network access via TCP

All Anybus network modules, as well as the integrated LAN port of select series offer standard TCP access via the default port **5025** (user-selectable, see device operating guide for setup menu or similar). TCP data transfer is used for the external communication via **ModBus RTU** or **SCPI**. For ModBus TCP protocol, port **502** is reserved and exclusive.

The port and other network related parameters can either be adjusted in the device's setup menu (if featured) or from outside via USB or on the website (see 2.6).

TCP/IP socket connection (IP:port) is intended for normal remote control access to the device when using an Ethernet interface.



The TCP connection can be automatically disconnected by the device after a certain amount of time elapsed with no data transmission. This is due to an adjustable timeout (default: 5 s). There is also another related option called "TCP keep-alive" which, if activated, turns the timeout ineffective, unless "TCP keep-alive" is not configured in the network.

3. Introduction

3.1 Communication with a device in general

After connecting the device via a digital interface to a PC, it's usually ready for access. Access can happen in several ways:

- Via a control and monitoring software supplied by the device manufacturer
- Via LabView VIs, supplied by the device manufacturer
- Via a custom programmed application which is usually created by the user
- Via other software, like a terminal program that can send text messages (SCPI)
- Via internationally standardised software for CAN, CANopen, Profibus or EtherCAT etc.

3.2 Control locations

Control locations are those locations from where a device is accessed. There are basically two: direct access (manual control) and external access (remote control). The user can switch between control locations just as the situation requires.

Following control locations are defined for a device:

Control location as displayed on the device	Description
-	If there is no specific control location indicated, the device is free for external access and all interface for remote control are enabled
Remote Analog, Remote USB etc.	Remote control is active
Remote	Remote control is active via any interface (PS 5000 / PSI 5000 only)
Local	Remote control is blocked, the device can only be controlled manually

Certain device series offer a feature to interrupt or to block remote control of the device completely. This is a setting named „**Allow remote control**“ or similar. In blocked state, the device will indicate „**Local**“ in the display. Activating this block may be required in an emergency situation where a software permanently controls the device from remote and thus may prevent user interaction. With this, the user can temporarily interrupt remote control in order to access the device for switching the DC input/output off or changing a setting.

Activating „**Local**“ condition will cause following:

- In case remote control via one of the digital interfaces is currently active („**Remote Ethernet**“ etc.), remote control will be deactivated and can be activated again later, once the „**Local**“ condition has been deactivated again.
- In case remote control via analog interface is currently active („**Remote Analog**“), then the remote control is only interrupted as long as condition „**Local**“ is active and returns automatically as soon as „**Local**“ is deactivated, because the analog interface has a steady signal on pin REMOTE, which permanently defines „Remote on“ unless the plug on the analog interface has been removed.

3.3 Message timing and command execution time

The timing of communication, more precisely the control over the chronological run of two subsequent messages, is not done by device and lies in the responsibility of the user.

Rule of thumb: the device can not process incoming messages as fast they can be technically transferred by the hardware of the used interface and its specifications. Thus it's important to time communication and wait a certain time before the next command is sent, no matter what interface is used. This doesn't include protocol related data traffic, like it occurs for example between a Profibus slave and its Profibus master, because this traffic is handled by the interface itself, not by the device.

It also applies:

- Queries to the devices, i.e. commands that read something, are executed faster and may be sent more often and in shorter intervals
- Write commands, i.e. commands that set a value or a status, are not immediately executed when received and the delay before execution varies

3.3.1 Execution time when writing

Due to different internal design of the series, different types of microcontrollers, which control the hardware and besides do communication with the PC, and also different firmwares the time for processing a set value or status command varies. It means, there is no fixed time between setting a value and the corresponding reaction on the DC output/input. An average value for current device situation can be determined by the user with triggering a measurement parallel to a command transfer.

ModBus & SCPI

3.3.2 Response time when reading

Reading something from a device is usually responded immediately, with a certain response time. There are generally two methods of communicating with a port:

- 1) Open port -> write query to port -> read response from port -> close port
- 2) Open port -> write query to port -> read response from port -> repeat write/read x times -> close port

Both methods have advantages and disadvantages. The primary advantage of method 2 over method 1 is that writing and reading can result in an even faster response time. The primary advantage of method 1 over method 2 is that closing the port also closes the connection which makes communication more stable, especially if the time between two write-read cycles is very long. The values in the table below have been acquired using method 1.

Reading a response from the port is generally required with ModBus, because there could also be an unexpected error message instead of an echo message (echo = OK). When using SCPI, reading from the port is only required after query commands, i.e. those ending with a "?", or when wanting to check for errors which requires to send another query command.



The response time of both, USB and Ethernet, may vary depending on the KE firmware version installed on your device and can shorter or longer than listed here.

Series	Protocol	Typical response times		
		USB	Ethernet	CAN/CANopen
ELR 9000 / EL 9000 B PSI 9000 (all series since 2014) PSB 9000 / PSBE 9000 PSE 9000	SCPI	<15 ms	<10 ms	-
	ModBus	<10 ms	<10 ms	≈2 ms
PS 5000	ModBus	~1 ms	-	-
PSI 5000 / PSI 9000 DT / PSI 9000 T / PS 9000 T / EL 9000 T EL 9000 DT / EL 3000 B / PS 3000 C	SCPI	1~3 ms	5~8 ms	-
	ModBus	~1 ms	~5 ms	-
PS 9000 (all series since 2014)	SCPI	1~3 ms	5~8 ms	-
	ModBus	~1 ms	~5 ms	-
ELR 5000	SCPI	-	1~3 ms	-
	ModBus	-	1~3 ms	-
ELR 10000 PSB 10000 PSI 10000	SCPI	tbd	tbd	tbd
	ModBus	tbd	tbd	tbd

ModBus & SCPI

3.3.3 Timing of messages

The minimum time between two messages, as listed below, primarily depends on the typical response time as listed in 3.3.2.

Series	Minimum time between two messages	Recommended time between two messages
ELR 9000 / ELR 9000 HP EL 9000 B / PSI 9000 (ab 2014) / PSB 9000 / PSE 9000 / PSBE 9000	USB / CAN / CANopen: 10 ms Ethernet: 15 ms	USB / CAN / CANopen: 15-20 ms, depending on protocol in use Ethernet: 20 ms
PS 5000	2 ms	5 ms
PSI 5000 / PSI 9000 DT / EL 9000 DT / EL 9000 T / PS 9000 T / PSI 9000 T / EL 3000 B	USB: 2 ms Ethernet: 8 ms	USB: 5 ms Ethernet: 15 ms
PS 9000 (from 2014)	USB: 2 ms Ethernet: 8 ms	USB: 5 ms Ethernet: 15 ms
ELR 5000	5 ms	10 ms
ELR 10000 PSB 10000 PSI 10000	tbd	tbd

ModBus & SCPI

3.4 Overview of the communication protocols

Except for series PS 5000, the below device series support two protocols: **ModBus** and **SCPI**. Basically, both can be used via RS232, USB and most of the Ethernet based interfaces. Exceptions are those related to dedicated standards, such as CAN, CANopen, Profibus, Profinet or EtherCAT.

When using an Ethernet port with ModBus protocol it requires an additional distinction between ModBus RTU and ModBus TCP. Series with a rigidly installed Ethernet port only support the **ModBus TCP frame** from a specific firmware version (see section „1.1.2. Validity“), which means the support for ModBus TCP can be installed with a firmware update.

Over Ethernet, the ModBus TCP reserved port 502 only supports ModBus TCP frames, while all other ports would only support frames with a ModBus RTU ("ModBus RTU over Ethernet") or SCPI message.



With **option 3W (GPIB+USB+Analog)** installed, as it's optionally available since Q3/2014 for select series, **only SCPI** can be used via GPIB. With USB, ModBus RTU is additionally supported.

Which device series support what protocol(s)?

Series	ModBus		SCPI
	RTU	TCP	
EL 3000 B / PS 3000 C	✓	not supported	✓
EL 9000 B / DT / T / B HP / B 2Q	✓	✓	✓
ELR 9000 / ELR 9000 HP / ELR 10000	✓	✓	✓
ELR 5000	✓	not supported	✓
PS 5000	✓	not supported	not supported
PS 9000 (alle Sub-Serien ab 2014)	✓	✓	✓
PSB 9000 / PSBE 9000 / PSB 10000	✓	✓	✓
PSE 9000	✓	✓	✓
PSI 5000	✓	✓	✓
PSI 9000 (alle Sub-Serien ab 2014)	✓	✓	✓
PSI 10000	✓	✓	✓

Special fact: **SCPI** and **ModBus RTU** can be used via USB or Ethernet (standard port) arbitrarily. The actual protocol is distinguished by the first byte of a message, which **has to be 0x00** for ModBus RTU.

Depending on the selection of the interface and the protocol you are going to use, a different part of this documentation will be relevant.

Users with a device supporting the optional interfaces modules (see section 2.2) have a wider selection. The table below list which module supports what protocol:

Interface	ModBus?	SCPI?	Other protocol
CAN	no	no	no (see „8. CAN“)
CANopen	no	no	CANopen (see „7. CANopen“)
RS232	yes (see „4. The ModBus protocol“)	yes (see „5. SCPI protocol“)	no
Profibus	no	no	Profibus (see „6. Profibus & Profinet“)
Ethernet	yes (see „4. The ModBus protocol“)	yes (see „5. SCPI protocol“)	ModBus TCP (see „4.5.5. ModBus TCP“)
ProfiNet	no	no	Profinet (see „6. Profibus & Profinet“)
ModBus TCP	yes (see „4. The ModBus protocol“)	yes (see „5. SCPI protocol“)	ModBus TCP (see „4.5.5. ModBus TCP“)
EtherCAT	no	no	EtherCAT (see „9. EtherCAT“)

3.5 Special characteristics of remote control

When using remote control via digital interface, some things have to be taken into account:

- Configuration or control of the function generator (where available) requires a certain procedure. This is described in 4.10.6 for ModBus resp. 5.4.12 for SCPI. The described procedure for ModBus basically also applies to any other protocol used by buses like CAN, CANopen, EtherCAT etc.
- Some ModBus registers resp. SCPI commands are intended for the setup of the device exactly like when doing it manually in the device setup menu (where featured). Those registers/commands are not particularly grouped or marked with colours and should only be used to switch between configurations of the device.
- The adjustment limits („Limits“, where available, see device manual), as adjustable in the device's setup menu, limit related set values from every control location, i.e. also in remote control via digital interface. This can lead to unexpected communication errors coming from the device when a value is too high/low. With SCPI language being used, these errors are not even returned automatically, because it's typical with SCPI to receive error messages only upon request. In order to be sure whether a set value has been accepted by the device or not, reading the set value is the only way.

3.6 Fragmented messages on serial transmissions

With RS232, Ethernet or even with USB it's possible, that the device receives fragmented messages. It means, a command is received in pieces together with a certain time gap and then interpreted by the device as multiple, but single and corrupt commands. Primarily SCPI commands are affected, because they are strings consisting of ASCII characters and do not have a checksum. Those strings could be sent by a serial interface character by character or as one single block, depending on the situation on the control side (PC). If a certain timeout elapses between to consecutive bytes, the message is considered as "completely received" by the device, due to the lack of a termination character, which is not generally required for ModBus or SCPI.

Since a certain firmware version a variable USB timeout has been implemented, which can be configure manually on the device (except for PS/PSI 5000) or via remote control, for example via SCPI (see section 5.4.11). If the communication between PC and device has a lot of communication errors due to possibly fragmented messages, the timeout should be increased step by step to eliminate the problem. It's advised to keep the timeout setting as low as possible, because at the end of every message the timeout has to elapse before the device can process the command.

When using SCPI, sending an additional termination character (typical LF, CR, or CRLF accepted), which is not required but accepted, will terminate the timeout immediately and let the device consider the message as completely received, so it can process.

3.7 Connection timeout

Socket connection to devices which support an Ethernet port have a connection timeout. This variable and user-adjustable timeout (see user manual of the device) closes the socket connection automatically on the device side if there was no communication going on between device and controlling unit (PC, PLC etc.) for the adjusted time. After the socket has been closed, connection can be established again anytime. The timeout becomes automatically ineffective, if the so-called "TCP keep-alive" (available since a specific KE firmware version) is activated and supported in the network.

3.8 Effective resolution when programming

All values related to voltage, current, power and resistance, that can be transferred to the device and which are transferred via the power stages to the DC input/output of the device have the same defined programmable resolution and an effective resolution. While the **programmable resolution** of a value is the same for every series (0-100 % = 0 - 0xCCCC = 0 - **52428**), even when using SCPI, the effective resolution depends on the ADC/DAC used in the hardware and is not the same in all series. See the table below.

The effective resolution determines the doable step width on the DC output/input. It calculates as **step width = rated value ÷ effective resolution**. E. g., for the power supply PSI 9080-510 3U the approximate step width of voltage would then be $80 \text{ V} / 26214 = \sim 3 \text{ mV}$. For the current it would be $510 \text{ A} / 26214 = \sim 19 \text{ mA}$.

However, tolerances add to the result when setting a value. The PSI 9080-510 3U from the example above has a voltage tolerance of max. 0.1%, as stated in the user manual. This is up to 80 mV. When setting, for example, 24 V the true output voltage is allowed to be within 23.92 V to 24.08 V range. The actual value, as readable from the device, already includes this tolerance (or error). If you would measure the actual output voltage with an external multimeter and it would read 24.03 V and you would want to it have closer to the desired 24 V, the software could adjust the set value in approx. 3 mV steps to further narrow the actual value to the set value.

Series	ADC/DAC	Effective resolution
EL 3000 B	12 Bit	4096
EL 9000 B 3U-24U / EL 9000 B HP / EL 9000 B 2Q	16 Bit	26214
EL 9000 DT	16 Bit	26214
EL 9000 T	14 Bit	16384
ELR 5000	16 Bit	26214
ELR 9000 / ELR 9000 HP	16 Bit	26214
PS 5000 / PSI 5000	16 Bit	26214
PSB 9000 / PSBE 9000 / PSE 9000 / PSI 9000 2U - 24U / PSI 9000 DT	16 Bit	26214
PS 9000 T / PSI 9000 T	14 Bit	16384
PS 3000 C	PWM	26214

3.9 Minimum slope (function generator)

This section is only valid for series featuring a function generator, such as:

- EL 9000 B / EL 9000 B HP / EL 9000 B 2Q / EL 9000 DT/ EL 9000 T
- ELR 9000 / ELR 9000 HP / ELR 10000
- PSI 9000 2U - 24U / PSI 100000
- PSI 9000 DT / PSI 9000 T
- PSB 9000 / PSB 10000

When programming the so-called arbitrary generator (also see user manual of the device for details), no matter what digital interface is used, the device may return errors related to the values in the so-called sequence points. Besides obvious errors like "value out of range" there is also a minimum slope to respect.

According to the description of the arbitrary generator in the device manual all sequence points have an AC part, which is only used to generate sine waves, and a DC part with a start and value. When start and end value are different, a slope is generated. This is natural in the functions for ramp, triangle and trapezoid.

That slope ($\Delta U/t$ or $\Delta I/t$) must fulfil a specific minimum value. In order to check if a certain rise/fall over time is doable, the minimum slope should be calculated for the rated values of your particular device.

Formula: **min. slope = 0.000725 * rated voltage or current ÷ s**

In relation to the parameters you set up for a sequence point, the device calculates the slope in the sequence point from "Start value of DC part", "End value of DC part" and "Sequence time" and compares it to the min. slope.

Example: the target device is an electronic load with 500 V and 30 A rating. A rising ramp on the current shall be generated. The min. slope calculates as: $\Delta I/t = 0.000725 * 30 A = 21.75 \text{ mA/s}$. If you wanted to do ramp of 0-20 A in 5 s, the slop would be 4 A/s, which is OK and doable. However, the same 0-20 A over 20 minutes is not possible and would be refused by the device.

The max. time for a certain ΔU or ΔI can be calculated: **$t_{\text{Max}} = \Delta U \text{ or } \Delta I \div \text{min. slope}$** .

For the above example with 0-20 A we get a $t_{\text{Max}} = 20 A / 0,02175 A/s = \sim 919 \text{ seconds}$.

Conclusion: long-time ramps over many minutes or even hours cannot be achieved using the function generator, but by using an alternative method, which is setting a certain number of steps over time using a PC software.

Here the effective resolution (see 3.8) comes into play. The electronic load from the example above could be an ELR 9500-30 with a programmable resolution of 52428 steps and an effective resolution of 26214 steps. In order to have it realistic, let's focus the 26214. It represents 0-100% = 0-30 A when working on the current. For 0-20 A it would then be 17476 steps. If you wanted to generate the 0-20 A ramp over 10 hours, you could set a new value every $10 \text{ h} / 17476 = \sim 2 \text{ seconds}$, while the value increases with every step by $20 A / 17476 = \sim 1.15 \text{ mA}$. This is a very fine step width and heavily impacted by device tolerances. Thus it's probably more reasonable to enlarge the period, for example to an increment of 11.5 mA every 20 s or 34 mA every minute. Using a constant period will result in a ramp with stairs of constant width and a more or less small height of 1.15 mA to 34 mA or different, just as you set it up.

4. The ModBus protocol



Before you continue reading this section, please verify if your device generally supports ModBus and also if ModBus is supported via the interface you are going to use. See section 3.4



Our devices are always ModBus slaves with address 0. This address cannot be changed.

4.1 General information about ModBus RTU

A message or telegram as defined by the ModBus RTU protocol consists of hexadecimal bytes, of which the first byte, the ModBus address, **must always be 0**. The first byte of a telegram is used to distinguish the telegram between ModBus and SCPI. A value between 1 and 41 in the first byte will cause a ModBus communication error, whereas from 42 (ASCII character: *) the telegram is considered as text message, as an SCPI command.

Format and length of a telegram are defined. The telegram has to be transmitted according to the specifications of the particular interface that is used. Normally, the user only has to take care for a correct message, rather than correct transmission. But there are also interfaces, like for example RS232, which do not feature communication safety and don't guarantee flawless transmission. Other interfaces support flawless transmission by using a checksum and/or software handshaking.

4.2 General information about ModBus TCP

The message protocol according to ModBus TCP standard is supported by the Anybus interface modules **ModBus TCP 1-Port** and **2-Port** (see section 2.2), as well as by series with rigidly installed Ethernet port (only from a specific firmware version), in both cases only via the default ModBus TCP port **502**. By definition, a ModBus TCP message requires an additional header, compared to ModBus RTU. This makes it impossible to use SCPI commands via this port. The rest of the message is identical to ModBus RTU, except for the not required checksum at the end. Information about the header can be found below. The below sections are related to the core part of ModBus messages, which is identical for both protocols. Further ModBus TCP related information can be found in „4.9. ModBus TCP in detail“.

4.3 Format of set values and resolution

Set values, as transmitted via digital interfaces, are always per cent values of the device's nominal values (U, I, P, R) and correspond at 100% to the hexadecimal value 0xCCCC (decimal: 52428). The total usable range is 0%...102% (0x0000...0xD0E5). The register lists for a particular series defines the range for all settable values.

It means, you can set a per cent value between 0% and 100% by sending hexadecimal values of 0x0000-0xCCCC resp. for supervision thresholds of device alarms like OVP it will be 0x0000-0xE147 for 0% to 110% resp. with some series 0x0000-0xD2F1 for 0 to 103%.

This means 52429 possible values for 0-100%. This is internally halved (bit 16 is reserved for sign), **so the effective resolution between 0 and 100% results in 26214 steps**.

4.4 Translating set values and actual values

Real values have to be translated to per cent values before transmitting them to the device, as well as per cent values read from the device are usually translated into real values in order to process them further. It always applies: 0xCCCC (hexadecimal) = 52428 (decimal) = 100% nominal value (U, I, P)

Translation is done by implementing these formulas into custom software:

Per cent value to real value	Real value to per cent value
<p>Real value = $\frac{\text{Rated value} * \text{per cent value}}{52428}$</p> <p>Example: The nominal voltage of your device is 80 V and actual voltage was read as 0x2454 (decimal: 9300). According to the formula above, the real actual value will be $(80 * 9300) / 52428 = 14,19$ V.</p>	<p>Per cent value = $\frac{52428 * \text{real value}}{\text{Rated value}}$</p> <p>Example: the power set value shall be 3150 W, the power rating of your device is 3500 W. According to the formula above we get a power set value of $(52428 * 3150) / 3500 = 47185 = 0xB851$.</p>



All set values are not only limited by the device's nominal values, but can also be limited by the adjustable "Limits" (where available)! Values exceeding the minimum or maximum of the adjusted range are rejected by the device.



When translating real values into per cent values (decimal or hexadecimal), it's often required to round up or down. We recommend to round naturally. Note that natural rounding can result in a translation value which is by 1 higher than expected.

4.5 Communication with the device via AnyBus modules

4.5.1 Ethernet

Continue to read in section 4.7.

4.5.2 Profinet / Profibus

The Profinet/IO module (1 or 2 ports) can be used to control and monitor a device using a network system, usually combined with an integrated PLC and proper software. For Profinet, the software selects the necessary Ethernet port, because this port can not be adjusted on the device. The standard Profinet communication is different and is handled by the field bus protocol via special software. The implementation of the device into Profinet resp. Profibus is described in section „6. Profibus & Profinet“. Continue to read in section 4.7.

4.5.3 CANopen

Continue to read in section 4.7. Also refer to section „7. CANopen“

4.5.4 CAN

Continue to read in section 4.7. Also refer to section „8. CAN“.

4.5.5 ModBus TCP

The protocol used here is standard ModBus in a ModBus TCP frame. TCP/IP transmission is not explained herein. Continue to read in section 4.7.

4.5.6 EtherCAT

EtherCAT uses proprietary software and usually CANopen over Ethernet (CoE) protocol. Continue to read in section 4.7. Also refer to sections „7. CANopen“ and „9. EtherCAT“.

4.6 Communication with the device via USB port

After connecting the device via USB cable and successful USB driver installation, the device is ready for access. The COM port, which is assigned to the new USB device (see Windows device manager) does not need configuration. It's based upon a so-called CDC driver (Communications Device Class), which is available for Windows XP and 7 (also Embedded) and for other operating systems, too. This driver generates the COM port for simplicity and can run data transmissions as fast as USB 2.0 can handle it. The typical serial settings are not effective and are ignored.

4.6.1 USB driver installation

The USB driver for the rear or front side USB port type B is included with the device on USB stick. It installs a signed driver for virtual COM ports on 32 bit or 64 bit Windows operating systems since Windows 7. Alternatively it's available as download from the website of the device manufacturer.

4.6.2 First steps

In order to communicate with the device, it actually just requires a software on the PC side which is able to open a COM port and send messages in either binary (ModBus protocol) or ASCII strings (here: SCPI) format.

For the latter one, simple terminal softwares suffice. For binary telegrams in hexadecimal format other tools are required, like Docklight (www.docklight.de). The device manufacturer can provide ready-to-use example project files for Docklight upon request. Those can help for a start and to see how the communication works correctly or at all. The project files contain a few basic messages in form of macros which can be sent by the click of a button.

To finally establish communication and access the device via USB, you just need to...

1. connect the device via USB (alternatively via any other digital interface).
2. install the USB driver (see 4.6.1).
3. run a terminal program.



- In order to control a device, i.e. changing values or status by switching the DC input/output on or off, it's required to activate remote control first, **by a command**. This doesn't happen automatically when sending the very first command!
- Switching to remote control may be blocked by the device. When using SCPI language, the device never returns error messages automatically, but only upon request.

4.7 About the register lists

Along with this programming guide, there are so-called register lists (usually one for each device series) included as PDF files. These lists give an overview about the remote programming features that are available for a certain device series when using binary communication protocols like ModBus, for which they are primarily made. They are also a substantial reference when controlling a device via a **field bus** (CAN, CANopen, Profibus, Profinet, EtherCAT) or accessing it in programming environments like **LabView** or **MatLab**, for example when trying to interpret values or to understand the function of a certain command.

The lists explain in compact format how the data in a binary message has to be interpreted or how a register (with CANopen resp. EtherCAT it's called "index") is specified. This will help the user to implement the device communication into custom software applications. Users who decide to work with SCPI command language usually do not need those lists. Later in this document, the SCPI commands are referenced in a separate chapter.

4.7.1 Columns "Function"

The heads of the 5 columns next to the ModBus address column contain the names and codes of the supported ModBus functions. An "x" in these columns mark the assignment of a register to any of the functions. For example, the so-called coil registers are usually writable and readable, so they're assigned to "Read Coils (0x01)" and "Write Single Coil (0x05)".

4.7.2 Column "Data type"

Data type	Length	
char	1 Byte	Single byte, used for strings
uint(8)	1 Byte	Single byte
uint(16)	2 Bytes	Double byte, also called word or 16bit integer
uint(32)	4 Bytes	Double word, also called long or 32bit integer
float	4 Bytes	Floating point value according to IEEE745 standard

4.7.3 Column "Access"

This column defines for every register whether the access is read only, write only or read/write.

R = Register is read only

W = Register is write only resp. would not return a reasonable value when read from

RW = Register can be read or written



It applies generally: Writing to a register which allows write) access (W, RW) is only possible during remote control!

4.7.4 Column "Number of registers"

With ModBus, a register always has a length of 2 bytes or a multiple of 2 bytes. This column tells how many 2-byte values are used by the register. The value is always the half of the value in column "Data length in bytes".

4.7.5 Column "Data"

This column tells additional information about the data which can be written to or read from the register. Two, four or more bytes can be interpreted in different ways, depending on data type and content.

4.7.6 Columns "Profibus/Profinet slot & index"

These columns (where available) are used by Profibus/Profinet users to link the registers in the register list via two values „index“ and „slot“ to data blocks (SFBs) in the PLC software. While „index“ is a direct parameter for the data block, the value „slot“ has to be used to find the address of a slot, which is variable, in order to get the parameter „ID“. For more see „6. Profibus & Profinet“.

4.7.7 Column "EtherCAT SDO/PDO?"

This column is only available in register lists for those series which support the optionally available Anybus interface modules, here in particular the EtherCAT interface.

The column marks which of the generally per device available ModBus registers can be accessed by the CANopen over Ethernet (CoE) protocol in form of indexes. Some of the marked registers are connected to PDOs, the rest is connected as SDOs. Devices supporting the EtherCAT interface contain a downloadable data object list. Which of the registers are connected to PDOs is described in section „9. EtherCAT“.

ModBus & SCPI

4.8 ModBus RTU in detail

This protocol can be used with via built-in USB interface (where available), the built-in Ethernet port (select series) and also with some of the optionally available AnyBus modules. The addressed object when using ModBus protocol is called register. This document uses the terms **address**, **register** or **register address**.



When transferring ModBus RTU messages via any Ethernet interface it's called "ModBus RTU over Ethernet", which is not the same as "ModBus TCP". ModBus TCP frames are supported via "standard" Ethernet ports as well, but only since a specific firmware version. See section 3.4.

4.8.1 Message types

Basically, the message system distinguishes between **query messages**, **control messages** and **response messages**. Query messages will cause the device to send a response message, while control messages only cause it to reply with a 1:1 echo, in order to confirm reception.

4.8.2 General

The devices also support the text based SCPI language, with automatic detection of the used protocol. When using ModBus, the first byte of every message has to be 0.

4.8.3 Functions

The second byte of a message contains a ModBus **function** code (**FC**, marked blue below), which determines whether the message is a READ or WRITE message. It also determines, whether one or multiple registers are accessed. The protocol, as described below, supports following ModBus functions (Date: 09-18-2019):

Function		Function name		Description	Example of use
Hex	Dec	Long	Short		
0x01	1	READ Coils	RSC, RC	Always reads 1 bit, but is returned as a full register with a 16 bit value. For example, the value 0xFF00 means "logic 1" or TRUE. <u>At this point it's different from the ModBus standard and may cause problems with ModBus software tools.</u>	Query the input / output condition
0x03	3	READ Holding Registers	RHR	Used to read n subsequent registers. Results in n*2 bytes of data in the response message.	Read the model name string (1-40 bytes)
0x05	5	WRITE Single Coil	WSC	Used to write 16 subsequent bits which are interpreted as 1 bit (TRUE or FALSE). <u>At this point it's different from the ModBus standard and may cause problems with ModBus software tools.</u>	Switch device to remote control.
0x06	6	WRITE Single Register	WSR	Used to write one register.	Set values (U, I, P etc.)
0x10	16	WRITE Multiple Registers	WMR	Used to write n subsequent registers. be used to write beyond the limits of a register block, for example when trying to write multiple set values (U, I, P) at once.	Write multiple values at once within a register block or write the so-called user text



The register list defines which of the above functions may be used with every register.



The bytes in a ModBus message are read from left to right (big endian format), except for the 16 bit ModBus RTU checksum where low byte and high byte are switched.

ModBus & SCPI

4.8.4 Control messages (write)

When sending a status, a value, multiple values or a text, the data part of the message requires to define at least the target register and one value to write. The protocol checks the message only regarding the max. length of the register. After the data part, the checksum is expected. So in case the data part would only contain the minimum two bytes and thus the message would fulfil the protocol requirements for the selected function code, the checksum would be expected at the position of the 7th byte. If there were further data bytes at that position or zeros and the checksum would be at a different position in the message, the device would return an error. Hence the device will return an error, no matter if the telegram is too short or too long, because the checksum is wrong. For message examples see „4.8.9. Examples of ModBus RTU messages“.

WRITE Single Register

Byte 0	Byte 1	Bytes 2+3	Bytes 4+5	Bytes 6+7
Addr	FC	Start reg.	Data word	CRC
0x00	0x06	0...65535	Value to write	Checksum ModBus-CRC16 ⁽¹⁾

WRITE Multiple Registers

Byte 0	Byte 1	Bytes 2+3	Bytes 4+5	Byte 6	Bytes 7-253	Last 2 Bytes
Addr	FC	Start reg.	Number	Count	Data bytes	CRC
0x00	0x10	0...65535	0...123	Number*2	n values to write	Checksum ModBus-CRC16 ⁽¹⁾

WRITE Single Coil

Byte 0	Byte 1	Bytes 2+3	Bytes 4+5	Bytes 6+7
Addr	FC	Register	Data word	CRC
0x00	0x05	0...65535	0x0000 (FALSE) or 0xFF00 (TRUE)	Checksum ModBus-CRC16 ⁽¹⁾



Attention! The entire 16 bits of the data word represent 1 coil only, for writing and reading.

4.8.5 Query message

When querying something from the device, the response is expected to be immediately and will be of varying length, but always of the same construction. For the query, the start register and the number of registers or coils to read are required. The base of the ModBus data format is a register, a 16 bit integer value, means a group of two bytes. Thus, when querying one register with function READ Holding Registers, the device will return two bytes and when querying two registers it returns 4 bytes etc. For READ Coils, the response will always be two bytes.

For message examples see „4.8.9. Examples of ModBus RTU messages“.

READ Holding Registers

Byte 0	Byte 1	Bytes 2+3	Bytes 4+5	Bytes 6+7
Addr	FC	Start reg.	Number	CRC
0x00	0x03	0...65535	Number of regs to read (1...125)	Checksum ModBus-CRC16 ⁽¹⁾

READ Coils

Byte 0	Byte 1	Bytes 2+3	Bytes 4+5	Bytes 6+7
Addr	FC	Start reg.	Number	CRC
0x00	0x01	0...65535	Must always be 1	Checksum ModBus-CRC16 ⁽¹⁾



Attention! Reading coils is here not according to the ModBus specification. Reading a coil always returns 16 coils, but all 16 are considered as one bit with either TRUE (0xFF00) or FALSE (0x0000).

⁽¹⁾ See „4.8.7. The ModBus checksum“

ModBus & SCPI

4.8.6 Response message (read)

A response from the device is usually expected after a query or if something has been set and the device confirms the execution.

Expected response for WRITE Single Register:

Byte 0	Byte 1	Bytes 2+3	Bytes 4+5	Bytes 6+7
Addr	FC	Start reg.	Data	CRC
0x00	0x06	0...65535	Written value echoed	Checksum ModBus-CRC16 ⁽¹⁾

Expected response for WRITE Single Coil:

Byte 0	Byte 1	Bytes 2+3	Bytes 4+5	Bytes 6+7
Addr	FC	Start reg.	Data	CRC
0x00	0x05	0...65535	Written value echoed	Checksum ModBus-CRC16 ⁽¹⁾

Expected response for WRITE Multiple Registers:

Byte 0	Byte 1	Bytes 2+3	Bytes 4+5	Bytes 6+7
Addr	FC	Start reg.	Data	CRC
0x00	0x10	0...65535	Number of written registers	Checksum ModBus-CRC16 ⁽¹⁾

Expected response for READ Holding Registers:

Byte 0	Byte 1	Byte 2	Bytes 3-253	Letzte 2 Bytes
Addr	FC	Data length in bytes	Data	CRC
0x00	0x03	2...250	Queried registers content	Checksum ModBus-CRC16 ⁽¹⁾

Expected response for READ Coils:

Byte 0	Byte 1	Byte 2	Bytes 3+4	Bytes 5+6
Addr	FC	Data length in bytes	Data	CRC
0x00	0x01	2	Queried bit as 1 register (always 16 coils)	Checksum ModBus-CRC16 ⁽¹⁾

Unexpected response (communication error):

Byte 0	Byte 1	Byte 2	Letzte 2 Bytes
Addr	FC		CRC
0x00	Function code + 0x80	Error code	Checksum ModBus-CRC16 ⁽¹⁾



A communication error can have several reasons, like a wrong checksum or when attempting to switch a device to remote control that has been set to "Local" or if it's already remotely controlled by another interface. See the communication error code list in „4.8.8. Communication errors“.

4.8.7 The ModBus checksum

The checksum at the end of ModBus RTU messages is a 16 bit checksum, but is not calculated as the usual CRC16 checksum. Furthermore, **the byte order** of the checksum in the message is **reversed**. Information about ModBus CRC16 and source code for implementation and calculation are available on the Internet, for example here:

http://www.modbus.org/docs/Modbus_over_serial_line_V1_02.pdf , section 2.5.1.2.

⁽¹⁾ See „4.8.7. The ModBus checksum“

4.8.8 Communication errors

Communication errors are only related to digital communication with the device. Other alarms or errors of any kind which can be generated and indicated by the device must not be mixed up with these.

The device will return unexpected error messages in case the previously sent message is in wrong format or if the function can not be executed by some reason. For example, when trying to write a set value with WRITE SINGLE REGISTER while the device is not in remote control. Then the message is not accepted and the device will return an error message instead of a confirmation message. The message format can be wrong if the checksum is bad or if you try to read a bit with function READ Holding Registers instead of READ COILS.

In case of an error, the response message contains the original function code added to 0x80, in order to identify the response as error message.

Overview of function codes in error messages:

FC error	Belongs to
0x81	READ COILS
0x83	READ HOLDING REGISTERS
0x85	WRITE SINGLE COIL
0x86	WRITE SINGLE REGISTER
0x90	WRITE MULTIPLE REGISTERS

Overview of the communication error codes which can be returned by the device:

Code	Error	Explanation
0x01	1 Wrong function code	The function code in byte 1 of the ModBus message is not supported. See „4.8.3. Functions“ for supported codes. The error also occurs when trying to read or write a register with a function code for which the register is not defined.
0x02	2 Invalid address	The register address you were trying to access with read or write is not defined for your device. Every device series may have a different number of registers. Refer to the separate ModBus register list of the series your device belongs to.
0x03	3 Wrong data or data length	The length of data in the message is wrong or the data itself. For example, a set value always requires two bytes of data. If the data part of the message would be one byte only or three bytes, then the data length would be wrong. Otherwise, when sending a set value of, for example, 0xE000 to a register for which the maximum value is defined as 0xCCCC, this would be wrong data.
0x04	4 Execution	Command could not be executed, depends on the situation
0x05	5 CRC	The CRC16 checksum at the end of the ModBus RTU message is wrong or has been transmitted in wrong byte order (high byte first instead of low byte)
0x07	7 Access denied	Access to a certain register is not allowed or read only while trying to write, or vice versa. The error also occurs when trying to write to a writable address while the device is not in remote control or in remote control from a different interface
0x17	23 Device in local	Indicates, that write access to the device is blocked by the "local" condition, so only read access is possible. "Local" means that remote control is not allowed.

An example: You attempted to switch the device to remote in order to control it from PC, but instead of an echo of your message it returns something like this: 0x00 0x85 0x07 0x52 0x92. This is an error message. The position of the function code contains the value 0x85. According to the first table above, this is related to the function WRITE SINGLE COIL. The error code in the message is 0x7 which means, according to the second table above, the device has denied the access. This can have different reasons, for example that the device is already in remote control via a different interface.

ModBus & SCPI

4.8.9 Examples of ModBus RTU messages



The examples can also be used for ModBus TCP, but they need to be extended by the required ModBus TCP header and stripped from the unnecessary checksum.

4.8.9.1 Writing a set value



Set values are adjustable limits for the physical values Current, Voltage, Power and Resistance (where available). They can only be written to a device, if it has been switched to remote control before via a digital interface.

Example: You want to set the current to 50%. According to the register lists, the „Set current value” is at address 501 (0x1F5) and assigned function is WRITE Single Register. Expecting the device to already be in remote control mode, the message to build then has to be like this:

Message to send:	<table border="1"><thead><tr><th>Addr</th><th>FC</th><th>Start</th><th>Data</th><th>CRC</th></tr></thead><tbody><tr><td>0x00</td><td>0x06</td><td>0x01F5</td><td>0x6666</td><td>0x325F</td></tr></tbody></table>	Addr	FC	Start	Data	CRC	0x00	0x06	0x01F5	0x6666	0x325F	Expected response:	<table border="1"><thead><tr><th>Addr</th><th>FC</th><th>Start</th><th>Data</th><th>CRC</th></tr></thead><tbody><tr><td>0x00</td><td>0x06</td><td>0x01F5</td><td>0x6666</td><td>0x325F</td></tr></tbody></table>	Addr	FC	Start	Data	CRC	0x00	0x06	0x01F5	0x6666	0x325F
Addr	FC	Start	Data	CRC																			
0x00	0x06	0x01F5	0x6666	0x325F																			
Addr	FC	Start	Data	CRC																			
0x00	0x06	0x01F5	0x6666	0x325F																			

In this case, the device is expected to return an echo of your message, indicating successful execution of the command. The display of the device should now show 50% of what's the maximum current of your device. For a power supply or electronic load with 510 A nominal current it should show 255.0 A or for a model with 170 A current rating it should show 85 A.

4.8.9.2 Query all actual values at once

The device holds three readable actual values of voltage, current and power. Electronic loads feature an additional actual resistance value in their displays, which can not be read via interface, but is calculated from the actual voltage and current. Hence the user can calculate the actual resistance himself.

Actual values can be queried separately or all at once. The advantage of a combined query is, that you gain a snapshot of the most recent actual values of the DC input or output. When querying separately, values may have changed already when sending the next query.

According to the register list, the actual values start from register 507. Three registers shall be read:

Message to send:	<table border="1"><thead><tr><th>Addr</th><th>FC</th><th>Start</th><th>Data</th><th>CRC</th></tr></thead><tbody><tr><td>0x00</td><td>0x03</td><td>0x01FB</td><td>0x0003</td><td>0x7417</td></tr></tbody></table>	Addr	FC	Start	Data	CRC	0x00	0x03	0x01FB	0x0003	0x7417	Possible response:	<table border="1"><thead><tr><th>Addr</th><th>FC</th><th>Len</th><th>Data</th><th>CRC</th></tr></thead><tbody><tr><td>0x00</td><td>0x03</td><td>0x06</td><td>0x2620 0x0C9B 0x091B</td><td>0x9EC0</td></tr></tbody></table>	Addr	FC	Len	Data	CRC	0x00	0x03	0x06	0x2620 0x0C9B 0x091B	0x9EC0
Addr	FC	Start	Data	CRC																			
0x00	0x03	0x01FB	0x0003	0x7417																			
Addr	FC	Len	Data	CRC																			
0x00	0x03	0x06	0x2620 0x0C9B 0x091B	0x9EC0																			

4.8.9.3 Read the nominal voltage of a device

The nominal voltage, like the other nominal values of current, power or resistance, is an important value to read from a device. They're all referenced for translating set values and actual values. It's recommended to read them from the device right after opening the digital communication line, unless the software shall not be universal.

According to the register list, the nominal voltage is a 4-byte float value in register 121.

Query message:	<table border="1"><thead><tr><th>Addr</th><th>FC</th><th>Start</th><th>No.</th><th>CRC</th></tr></thead><tbody><tr><td>0x00</td><td>0x03</td><td>0x0079</td><td>0x0002</td><td>0x1403</td></tr></tbody></table>	Addr	FC	Start	No.	CRC	0x00	0x03	0x0079	0x0002	0x1403	Possible response:	<table border="1"><thead><tr><th>Addr</th><th>FC</th><th>Len</th><th>Data</th><th>CRC</th></tr></thead><tbody><tr><td>0x00</td><td>0x03</td><td>0x04</td><td>0x42A00000</td><td>0xFE99</td></tr></tbody></table>	Addr	FC	Len	Data	CRC	0x00	0x03	0x04	0x42A00000	0xFE99
Addr	FC	Start	No.	CRC																			
0x00	0x03	0x0079	0x0002	0x1403																			
Addr	FC	Len	Data	CRC																			
0x00	0x03	0x04	0x42A00000	0xFE99																			

Also see 4.8.6. The response contains a float value according to IEEE754 format, which translates to 80.0.

4.8.9.4 Read device status

All device report their device status in a register, for series ELR 9000 and PSI 9000 this is register 505. Devices of other series can have a different address for this status register.

Query message:	<table border="1"><thead><tr><th>Addr</th><th>FC</th><th>Start</th><th>No.</th><th>CRC</th></tr></thead><tbody><tr><td>0x00</td><td>0x03</td><td>0x1F9</td><td>0x0002</td><td>0x1417</td></tr></tbody></table>	Addr	FC	Start	No.	CRC	0x00	0x03	0x1F9	0x0002	0x1417	Possible response:	<table border="1"><thead><tr><th>Addr</th><th>FC</th><th>Len</th><th>Data</th><th>CRC</th></tr></thead><tbody><tr><td>0x00</td><td>0x03</td><td>0x04</td><td>0x00000483</td><td>0xA992</td></tr></tbody></table>	Addr	FC	Len	Data	CRC	0x00	0x03	0x04	0x00000483	0xA992
Addr	FC	Start	No.	CRC																			
0x00	0x03	0x1F9	0x0002	0x1417																			
Addr	FC	Len	Data	CRC																			
0x00	0x03	0x04	0x00000483	0xA992																			

Also see 4.8.6. The response contains the value 0x483 which states that the device is in remote control via the USB port, that the DC input/output is switched on and that CC (constant current) mode is active.

4.8.9.5 Switch to remote control or back to manual control

Before you can control a device from remote, it's required to switch it to remote control. This is done by sending a certain command.



The device will never switch to remote control automatically and can not be remote controlled with being in this condition. Reading from all readable registers is always possible.



The device will never exit remote control automatically, unless it's switched off or the AC supply is otherwise interrupted. Remote control can be left by a certain command. It then switches back to manual control.

Switching to remote control may be inhibited by several circumstances and is usually indicated by an error message:

- Condition „**Local**“ is active (check the display on the front of your device or read the device status), which will prevent any remote control
- The device is already remotely controlled by another interface
- The device is in setup mode, means the user has accessed the setup menu and not left it yet

► How to switch a device to remote control:

1. If you are using the ModBus RTU protocol, you need to create and send a message according to the description above, for example 00 05 01 92 FF 00 2D FA
2. Once the switchover to remote control has been successful, the device will usually indicate the new condition in the display or with a LED, as well as it echoes the message as a confirmation

In case switching to remote control would be denied by the device, because option “Allow remote control = No” is set (example from ELR 9000 series, other series may differ), then the device will return an error message like 00 85 17 53 5E. According to ModBus specification, this is error 0x85 with error code 0x17.

Leaving remote control can be done in two ways: using the dedicated command or by switching the device to “**Local**” condition. We will consider the first option, because this is about programming.

► How to exit remote control:

1. If you are using the ModBus RTU protocol, you need to build and send a message according to the description above, for example 00 05 01 92 00 00 6C 0A.

4.9 ModBus TCP in detail

This section is only about the differences to RTU. The core of a ModBus TCP message is ModBus RTU. Refer to „4.8. ModBus RTU in detail“ for more information. Differences of ModBus TCP compared to ModBus RTU:

- The message requires an additional 6 bytes long MBAP header
- The checksum is omitted (2 bytes)
- Transmission only via reserved port 502; any other port won't accept ModBus TCP frames

Per definition, ModBus TCP messages are always 4 bytes longer than **ModBus RTU** messages. The MBAP header is specified like this:

Bytes	Meaning	Explanation
0 + 1	Transaction identifier	This identifies the message. It's copied by the device in the response and is used to identify a certain message in a pool of incoming transmissions if multiple devices are communicating with the PC and the response is not immediately. The identifier is an arbitrary value between 0 and 65535.
2 + 3	Protocol identifier	Here always 0 = ModBus protocol
4 + 5	Length	Number of remaining bytes in the message, i.e. the length of the ModBus RTU core message minus 2.

4.9.1 Example for a ModBus TCP message

The example for READ Holding Registers from „4.8.9.3. Read the nominal voltage of a device“, extended by the MBAP header (arbitrary transaction identifier 0x4711 used):

Query message:

MBAP header	Addr	FC	Start	Data
0x4711 0x0000 0x0006	0x00	0x03	0x0079	0x0002

Possible response:

MBAP header	Addr	FC	Length	Data
0x4711 0x0000 0x0007	0x00	0x03	0x04	0x42A00000

The example is a query for reading the device's nominal voltage. The response contains a floating point value in "Data", which translates to 80(V).

4.10 Explanation about specific registers

For the abbreviations of the devices series see „1.1.2. Validity“.

Many of the commands resp. register related options are self-explaining, but not all of them. Some of the not self-explaining ones will be handled below.

4.10.1 Register 171

This allows to write and read an arbitrary string of up 40 characters, which can be used to uniquely identify a device amongst multiple units of the same model. It's permanently stored after being written.

4.10.2 Register 411

Described for SCPI in „5.4.15 Commands for alarm management“ on page 71.

When using ModBus, this register is intended to reset alarm bits as represented in the device status (register 505, see below). Until these are not reset, which is considered as an acknowledgement, the bits from previously occurred alarms remain set, even if the alarms are gone already. Alarms which are still present while register 411 is used to reset the alarm bits will of course be excluded from resetting. There is an exception: the device alarm OT (bit 19, overtemperature). This will be cleared automatically once the unit has cooled down. After resetting the alarm bits, device alarms can only be read in form of an alarm counter (registers 520 - 524).

4.10.3 Registers 500-503 (Set values)

These are the most important registers to work with, because they define the DC output/input values of voltage, current, power and resistance (where featured). With ModBus, any set value is transmitted as per cent value of the nominal device values (0...100%), whereas for SCPI real values are used.

Generally, before you can use R mode with devices where internal resistance is featured, it has to be activated (register 409), else the set value is ignored.

For power supply devices of series PSI 9000 (as from 2014) and the PV function, which is only featured there, the set value for current (register 501) is interpreted as irradiation value, as long as the device is in "PV mode". Means, while the function is running, this register does not define the current limit for your device, but a parameter called irradiation, which is commonly used in solar panel simulation. In manual operation, irradiation can be adjusted in 1% steps between 0% and 100%. With the set value of current it's also 0-100%, according to definition of register 501, but with a significantly higher resolution.

4.10.3.1 Additional registers 498, 499 and 504

With date 04-2019 series PSB 9000 and PSBE 9000 feature three additional set values registers for the so-called sink mode operation. These are 498 (power), 499 (current) and 504 (resistance).

4.10.4 Register 505 (Device status)

Another important register, as it represents the device condition in one 32 bit value (ModBus). Some bits are grouped and have to be interpreted like that. According to the register list, bits 0-4 of registers 505 are a group that represents the so-called control location (see „3.2. Control locations“). By reading this register you can furthermore detect if the device is already in remote control to see if command "Remote mode = on" was executed by the device.

With SCPI, some but not all of these 32 bits of this register are represented in the status registers "Questionable" and "Operation". See „5.4.2. Status registers“.

4.10.4.1 When running master-slave

During master-slave operation (where featured), the status register uses bit 29 ("MSS") to indicate the so-called master-slave safety mode, which is activated every time the master detects any problem in the communication with the slave(s), which can occur due to a connection failure or heavy electrical interferences. The master unit will then set this bit and switch off all DC outputs/input of the slaves being still online. Offline slaves will put themselves into a similar state and switch off DC.

After removal of the problem cause, the MS system has to be re-initialised, which also clears the bit.

4.10.5 Registers 650 - 662 (Master-slave configuration)

ELR9	ELR5	PS9	PSI9	PSI5	PS5	PSE	DT	PST	PSIT	PSB	EL3	PSBE	PS3
✓	–	–	✓	–	–	✓	–	–	–	✓	–	✓	–

This block of registers is used to configure the master-slave operation mode (short: MS) the same as you can do it in the setup MENU of your device. Refer to the device's operating guide about how the MS works and what do to in preparation of its remote control. For remote control of a MS system, it's expected to be fully wired. Before MS operation, slave units can be configured remotely, but during MS operation they can only be monitored, if required. It's, however, recommend to only control the master unit. Configuration and activation of MS operation can also be done manually and remote control can be taken over later after the master has initialised the system.

With the MS system not being set up yet, these registers have to be used in a certain order on any unit:

1. Switch to remote control with register 402.
2. Activate MS operation mode with register 653.
3. Select with register 650 whether the unit you are configuring will be Master or Slave.

Further steps, only to be performed on the master unit:

4. Initialise the MS system with register 654.
5. (with electronic loads only and also only required when running two-quadrants operation)
Set the unit to be Share bus slave (else it would be master) with register 652.
6. Optional: check with register 655, whether the initialisation has been successful.
7. Optional: Query the number of initialised slaves with register 662 --> in case the returned number does not match the number of slave units you want to use in the MS system, check the settings of all units and the cabling and repeat the initialisation.
8. Optional: read the nominal values (registers 656-660) of the previously initialised MS system to be used as value translation reference while running the MS.



From firmware KE 2.13 (ELR, PSI) the devices support reading the ratings of voltage, current, power and resistance even in MS mode via registers 121 - 129, so registers 656, 658 and 660 are actually obsolete. Alternatively they can still be used, but without the option to read the max/min resistance of the MS system. This is circumvented by reading the rated values from the master and dividing it by the number of included units.

9. Optional: configure alarm thresholds, event thresholds and set value limits.

During MS operation, the remotely controlled master unit can be accessed like a single unit, with a few exceptions (see device manual). Set values and actual values are always per cent values related to certain nominal values. Access to those registers is described in the other sections.

4.10.6 Registers 850 - 6695 (Function generator)

ELR9	ELR5	PS9	PSI9	PSI5	PS5	PSE	DT	PST	PSIT	PSB	EL3	PSBE	PS3
✓	–	–	✓	–	–	–	✓	–	✓	✓	–	–	–

The integrated function generator is a complex feature. It's configured and loaded with a lot of registers. Before you can run a function, setup is required every time and in a certain order.

First of all, you need to decide which one of the two basic function generators you want to use: **arbitrary** or **XY**. Other functions, such as battery test or MPP tracking, belong to the function generator, but are realised only by code.

All further steps depend on this selection.



All function generator settings and loaded data (sequences, XY table) are not stored inside the device and have to be loaded into the device every time before you can use the function generator. These data and settings are completely separate from what you can setup and define for the function generator manually when using the control panel and touch display.

4.10.6.1 Procedure for the arbitrary generator

This generator is used to create wave functions like sine, square, triangle or trapezoidal.

Step 1:

Select, whether to apply the function to the voltage U (register 851) or the current I (register 852). Before you haven't made this selection, the device can not accept sequence point data, because the sequence data is run through a plausibility check against the device's adjustment limits.

ModBus & SCPI

Step 2:

Define start sequence point (register 859), end sequence point (register 860) and number of cycles of that block to repeat (register 861).

Step 3:

Load data for x out of 99 sequence points (registers 900-2468, 8 values per sequence point).

Step 4:

Set global voltage limit (register 500), if the function is applied to the current. Else set global current limit (register 501, plus 499 for PSB 9000 series), if the function is applied to voltage. Set global power limit (register 502, plus 498 for PSB 9000 series) for both modes.

Step 5:

Control the function generator with start/stop (register 850).

Step 6:

When finished, leave the function generator by deselecting your former selection of either U (register 851) or I (register 852) again.

4.10.6.2 Programming example for the arbitrary generator

Before you can configure the arbitrary generator for a ramp it's necessary to think about the best way to achieve the ramp generation. It's important to keep in mind that the arbitrary generator stops at the end of the function run, unless you set the repetition to infinite. After a stop, the DC input/output remains switched on. In case of a ramp, this is wanted, because the end value shall usually remain set for time x. However, the device will go to static mode again, setting the static set values of U, I and P. The static values also apply for the period before the function run and for situations when the DC output/input is already switched on.

The stop action and the static values are thus a little problematic for the ramp function. Why? Supposed, you wanted to have a power supply generate a ramp starting from 0 V. The static value for U (voltage) would then be set to 0. But after the function stop, the device would also set 0 V and the voltage would drop from whatever value has been set during the function run. Conclusion: the static value of voltage has to be part of the function.

In order to achieve this, the function has to consist of two parts: one for the rising or falling ramp and the other for the static value. This can be done using two sequences of the arbitrary generator.

Assumption: you have a power supply and the ramp shall start from 0 V and rise to 50 V within 6 seconds. The end voltage shall remain constant for 3 minutes (the time can be varied at will). Sequences 1 and 2 will be used. Remote control is already active, we only need to configure the sequences. Since the ramp will make the voltage rise linearly, using only the DC part of a sequence, the parameters for the AC part (indexes 0 - 4) should be set to zero in order to avoid remainders which could disturb the correct wave generation.

The first step is to **activate function generator mode**, in this case we select arbitrary generator for U:

Addr	FC	Start	Data	CRC
0x00	0x05	0x0353	0xFF00	0x7DBE

Next step is to create the **ModBus message to configure sequence 1, the rising ramp**. According to the register list start register 900 (WMR, function code 0x10) is assigned to sequence 1. Because the data part would not fit the width of this document's page size, the 8 float values are below each other:

Addr	FC	Start	Regs	Bytes	Data	CRC	Description
0x00	0x10	0x0384	0x10	0x20	0x00000000		Start value of AC part: 0 V
					0x00000000		End value of AC part: 0 V
					0x00000000		Start frequency of AC part: 0 Hz
					0x00000000		End frequency of AC part: 0 Hz
					0x00000000		Start angle of AC part: 0°
					0x00000000		Start value of DC part: 0V
					0x42480000		Start value of DC part: 50V
					0x4AB71B00	0x5A14	Rise time in μ s: 6,000,000 (6 seconds)

ModBus & SCPI

After this, the **ModBus message to configure sequence 2, the static voltage** would be next. Start register here is 916:

Addr	FC	Start	Regs	Bytes	Data	CRC	Description
0x00	0x10	0x0394	0x10	0x20	0x00000000		Start value of AC part: 0 V
					0x00000000		End value of AC part: 0 V
					0x00000000		Start frequency of AC part: 0 Hz
					0x00000000		End frequency of AC part: 0 Hz
					0x00000000		Start angle of AC part: 0°
					0x42480000		Start value of DC part: 50V
					0x42480000		Start value of DC part: 50V
					0x4D2BA950	0x6AD7	Sequenz time in μ s: 180,000,000 (180 seconds = 3 minutes)

And as last step, configuration of the arbitrary generator itself:

Addr	FC	Start	Data	CRC	Description
0x00	0x06	0x035B	0x0001	0x384C	Register 859, WSR, start sequence: 1
0x00	0x06	0x035C	0x0002	0xC98C	Register 860, WSR, end sequence: 2
0x00	0x06	0x035D	0x0001	0xD84D	Register 861, WSR, sequence cycles: 1
0x00	0x06	0x01F5	0xCCCC	0xCC80	Register 501, WSR, global current limit: 100%
0x00	0x06	0x01F6	0xCCCC	0x3C80	Register 502, WSR, global power limit: 100%



Setting the global values (current, power) to maximum or any other value that wouldn't interfere the ramp generation is necessary, especially when running multiple devices in master-slave where those set values also limit the slaves' output.

Now the entire function setup is done and the function can be started. If the DC output of your device would still be off when starting the function, it will automatically switch on. Alternatively, you could switch it on separately with the corresponding command and before actually running the function. But it's not necessary here, because the voltage shall start to rise from 0 V. In other situations where the starting level is not zero, it would be required to switch on the DC output first and wait for the voltage to settle.

For the number of sequence cycles 1 is sufficient, but it can be changed at will. The the whole function would be repeated after 3 minutes and 6 seconds. The voltage, when using a power supply, would not instantly drop to 0 V at the end of the first function run and before the second one starts. It depends on the load how long the voltage takes to sink and the ramp, when being graphically recorded on an oscilloscope, could look different than expected. This could be circumvented by adding a third sequence which only uses some time for the voltage to go down.

Addr	FC	Start	Data	CRC	Description
0x00	0x05	0x0352	0xFF00	0x2C7E	Register 850, WSC, Run function

ModBus & SCPI

4.10.6.3 Procedure for the XY generator

Step 1:

Select the XY function mode with following registers:

Mode	PSB 9000 series	All other series with XY generator
UI	not available	854
IU	856	855
Simple PV (only with power supplies)	856	426
FC (only with power supplies)	856	854 (as UI mode)

Step 2:

Load the XY table data in 256 blocks of 16 values (registers 2600 - 6695). This corresponds to max. 4096 values for a measurement range of 0-125% U_{Nom} or I_{Nom} . Less data can also be loaded, for instance 3277 values for 0-100%. All values which are not set result in 0 V or 0 A.

Step 3:

This step is only required with older firmware versions. Rule of thumb: if the corresponding register list for the firmware version of your device still lists register 858, it must be used.

Submit table data (register 858).

Step 4:

Set static values which are not affected by the table

UI function: current (register 501 or CURR command) and power (register 502 or POW command)

IU function: voltage (register 500 or VOLT command) and power (register 502 or POW command)

Step 5:

Run the function generator by switching the DC input/output of your device on (register 405). For PV mode you may also want to control irradiation while the function is running. This is done by sending set values to register 501 (current), where 100% corresponds to a factor of 1 and 0% to a factor of 0. This factor is multiplied to the simulated current I_{MPP} of the MPP which usually is situated somewhere on the PV curve you loaded in step 2.

Step 6:

Exit the function generator by deselecting your former mode setting from step 1 via the same registers.

4.10.7 Registers 850 - 1692 (Sequence generator)

ELR9	ELR5	PS9	PSI9	PSI5	PS5	PSE	DT	PST	PSIT	PSB	EL3	PSBE	PS3
-	✓	-	-	-	-	-	-	-	-	-	-	-	-

The so-called sequence generator of ELR/ELM 5000 series is a simplified version of the arbitrary generator of other series, thus using some of the same registers. According to the register list for ELR 5000 series, a block of registers between 850 and 1692 is used to configure the 100 sequence points and to control the generator.

4.10.8 Registers 850 - 854 and 900 - 908 (Function generator EL 3000 B)

ELR9	ELR5	PS9	PSI9	PSI5	PS5	PSE	DT	PST	PSIT	PSB	EL3	PSBE	PS3
-	-	-	-	-	-	-	-	-	-	-	✓	-	-

The function generator of the 2017 released series EL 3000 B (short: EL3) is based on a ramp generator, thus offering functions like ramp, triangle, rectangle and trapezoid. It partly uses the same registers as with other series, but they are different in handling.

ModBus & SCPI

4.10.8.1 Programming example

Supposed you wanted to apply a rectangle on the current of an EL 3080-60 B, with an amplitude of 8 A, an offset of 1 A and a frequency of 50 Hz with duty cycle 9:1. Following registers would have to be loaded in the given order from top to bottom:

Register	Name	Purpose
852	Select I	Switch the function generator to apply the generated signal to the current. Must be set first because only then the device can check values written to the other registers for validity
900	Static level 1	Offset, shall be set to 1 A. This translates to hexadecimal percental value 0x0369.
901	Static level 2	Amplitude + offset, shall be set to 9 A, hence 0x1EB1.
902 / 906	Rise / fall time	Since the desired wave form is rectangular, these two time values should be 0, but the minimum is 3 μ s, so the registers are written with a float value of 3.
904	Hold time level 2	Relates to the 90% pulse. With a frequency of 50 Hz the period is 20 ms and the 90% are 18 ms (=18000 μ s). Thus write a float value of 18000 to this register.
908	Hold time level 1	Relates to the 10% pause. With a frequency of 50 Hz the period is 20 ms and the 10% are 2 ms (=2000 μ s). Thus write a float value of 2000 to this register.

After the configuration, the function run can be started.

Register	Name	Purpose
850	Start / Stop	Start the function generator with 0xFF00. It will run with the configured parameters until stopped by sending 0x0000 or due to a device alarm.

This FG is an exception, because it allows for sending and submitting new values during the function run. If required, you would first configure the wave with registers 900 - 908 anytime and then submit with 854. After the current period, which is defined by the last valid time values, has elapsed, the new values would become effective. The period cannot be stopped in the middle in order to change the parameters. This is only achieved by stopping the FG.

Register	Name	Purpose
854	Submit new function data during run	Submit the new data with 0xFF00. If the new data was not yet written, the former data will remain valid.

4.10.9 Registers 9000 - 9009 (Adjustment limits)

ELR9	ELR5	PS9	PSI9	PSI5	PS5	PSE	DT	PST	PSIT	PSB	EL3	PSBE	PS3
✓	✓	✓	✓	–	–	✓	✓	✓	✓	✓	✓	✓	✓

For SCPI, this is explained in „5.4.8. Commands for adjustment limits“. ModBus users should also read that section for the general handling of these settings. Apart from that, setting these parameters is like setting a set value (U, I, P, R).

4.10.10 Registers 10007 - 10900

ELR9	ELR5	PS9	PSI9	PSI5	PS5	PSE	DT	PST	PSIT	PSB	EL3	PSBE	PS3
✓	✓	✓	✓	✓	–	✓	✓	✓	✓	✓	✓	✓	✓

Those registers can be used to remotely configure the various built- in or optionally available digital interfaces for the above stated series. The registers are connected to the corresponding settings in the device's setup menu, where featured.

Contrary to manual control, the settings for the pluggable interface modules of series IF-AB (for PSI 9000 3U series etc.) can even be configured while the interface module is not yet installed.

4.10.11 Registers from 11000 (MPP tracking feature)

ELR9	ELR5	PS9	PSI9	PSI5	PS5	PSE	DT	PST	PSIT	PSB	EL3	PSBE	PS3
✓	✓	–	–	–	–	–	✓	–	–	✓	✓	–	–

The MPP tracking feature is only available with electronic load devices and with the bidirectional power supply series PSB 9000. With this feature the device emulates the characteristics of a solar inverter device when seeking to find the maximum power point (MPP) of a solar panel. More details about this feature and the available modes are in the user manual of those series supporting this feature.

ModBus & SCPI

Registers 11000 - 11016 are related to the configuration parameters as you would adjust them on the display of the load device. Registers 11100 - 11199 are related correspond to the "load voltage values from USB stick" function when using manual control, while parameters 11200 - 11499 correspond to the "save the results to USB stick" function when using manual control and after MPP4 mode has been finished gathering data.

4.10.11.1 Programming example for MPP4 mode

Mode MPP4 is available for remote control in all the above listed series, but not with all of them also on the control panel (HMI) and thus not described in the user manual. If you need more information about this mode, we suggest to refer to another user manual, for example from EL 9000 B 3U series.

The table shows the sequence of commands to send in order to load and run a user defined curve with 75 points.

Register	Name	Purpose
11000	Select MPP4	Switch the function generator to mode MPP4
11000 - 11174	Load curve data	Load 75 voltage values on an user defined curve. The next two steps define the actual range of points to run through, which ideally matches the number of loaded points. In case a point is processed which has not been loaded, the device will set 0 V.
11015	Set end point	Defines the end point of a range of points to run through. Can be an arbitrary value between 1 and 100. Since the start point can't be higher than the end point, the end point is set first.
11014	Set start point	Defines the start point of a range of points to run through. Can be an arbitrary value between 1 and end point, because it can't be higher than the end point.
11013	Tracking interval	Defines the time (in milliseconds) between two curve points.
11016	Repetitions	Defines the number of additional cycles. The result data, which can be read later, will always contain the data from the last cycle. If the curve shall be run only once, set this to 0.
11010	Start tracking	After the start the device will set the voltage of the first point in the defined range, measure current and power and store the values. Then continue to the next point etc. This mode stops automatically after a duration which results from the tracking interval, the number of points in the range and the repetitions. The test can be stopped anytime with this register.
11011	Read status	optional: read the status of the tracking run in order to determine when it's finished
11012	Read errors	optional: read possible errors during or after the test to determine if the test has run through successfully

4.10.12 Registers from 11500 (battery test)

ELR9	ELR5	PS9	PSI9	PSI5	PS5	PSE	DT	PST	PSIT	PSB	EL3	PSBE	PS3
✓	-	-	-	-	-	-	✓	-	-	✓	✓	-	-

Devices with the capability of running as electronic loads, such as series EL 9000 B or PSB 9000 offer a battery test function for manual control on their HMI. With date 04-2019, this feature is available for remote control with the above listed series. Remote battery test configuration and control can then be brought to these device series via firmware update.

Same as with manual control there are two modes to choose from, for static or dynamic current. The required parameters for both modes are written separately, while control and evaluation at test end are the same for both.

The registers are connected to the parameters on display. Thus it's recommended to read the section about the battery test in the corresponding device manual before starting here. A short overview:

Register	Purpose
11535	Activates the battery test mode and selects between static and dynamic (current) mode
11500 - 11513	Configuration of the static battery test mode
11514 - 11531	Configuration of the dynamic battery test mode
11532 - 11534	Test run control
11535 - 11540	Evaluation (time, Ah, Wh)

ModBus & SCPI

4.10.13 Register from 12000 (advanced photovoltaics simulation acc. DIN EN 50530)

ELR9	ELR5	PS9	PSI9	PSI5	PS5	PSE	DT	PST	PSIT	PSB	EL3	PSBE	PS3
-	-	-	✓	-	-	-	-	-	-	✓	-	-	-

Photovoltaics simulation is a function based on the XY generator and is only featured with some power supply series. With date 04/2019 these are:

- PSI 9000 2U
- PSI 9000 3U
- PSI 9000 WR 3U
- PSB 9000 / PSB 10000

The advanced simulation according to DIN EN 50530 is supported from firmwares KE 2.19/HMI 2.10 (PSI) resp. KE 2.25/HMI 2.04 (PSB). All ModBus registers which represent parameters related that to this simulation and which can be written to the device or read from are referenced in the EN 50530 standard document. The document is furthermore the reference for the user regarding setup and correct use of this simulation feature.

The procedure to set up and control the extended PV simulation using ModBus protocol is not different to manual handling (see user manuals of the devices) on the device's HMI or when using SCPI commands (see examples in section „5.5.3 Programming examples for PV simulation (DIN EN 50530)“ on page 87). These step by step examples have an extra column in the table that holds the related ModBus register number. One of these examples (nr. 2) converted to ModBus RTU format (percental set values translated for a device with 80 V and 170 A rating):

Configuration (before the start)

Nr.	Command	Description
1	00 05 01 92 FF 00 2D FA	Activate remote control
2	00 06 2E E1 00 03 91 04	Activate PV simulation mode DAYET
3	00 06 2E F0 00 00 81 00	Select technology: Manual (all required parameters must be defined, here as with commands 4-10)
4	00 10 2F 02 00 02 04 3F 4C CC CD F7 ED	Fill factor voltage (FF _U): 0,8
5	00 10 2F 04 00 02 04 3F 47 AE 14 EE FF	Fill factor current (FF _I): 0,78
6	00 10 2F 06 00 02 04 39 9D 49 52 84 57	Temperature coefficient α for I _{SC} : 0,0003 /°C
7	00 10 2F 08 00 02 04 BB 44 9B A6 A1 7F	Temperature coefficient β for U _{OC} : -0,003 /°C
8	00 10 2F 0A 00 02 04 3D 94 7A E1 00 75	Scaling factor C _U for U _{OC} : 0,0725
9	00 10 2F 0C 00 02 04 39 66 AF CD 7F D1	Scaling factor C _R for U _{OC} : 0,00022 m ² /W
10	00 10 2F 0E 00 02 04 3B 4E 70 3B A7 CE	Scaling factor C _G for U _{OC} : 0,00315 W/m ²
11	00 05 2E F1 FF 00 D5 30	Select input mode: ULIK
12	00 06 2F 10 61 47 E8 A8	Set open circuit voltage: 38 V (=0x6147)
13	00 06 2F 11 08 6F 97 26	Set short-circuit current: 7 A (=0x086F)
14	00 05 2E F2 FF 00 25 30	Activate data recording
15	00 05 2E E5 00 00 D4 C4	Deactivate interpolation of day trend data
16	00 06 01 F4 61 47 A1 B7	Set global voltage limit: ≥U _{oc} (=0x6147)
17	00 06 01 F6 CC CC 3C 80	Set global power limit: 100% (=0xCCCC)

Write day trend data (before the start)

Nr.	Command	Description
18	00 05 2E E6 FF 00 65 34	Select access mode: write
19	00 05 2E E7 FF 00 34 F4	Delete former data (should be executed every time before loading new data)
20	00 10 2E EA 00 06 0C 00 00 00 01 44 44 66 66 00 00 03 E8 88 8A	Write 1 st day trend data set: Irradiation: 500 W/m ² (=0x4444) Temperature: 20°C (=0x6666) Dwell time: 1000 ms (=0x000003E8)
		<i>The dwell time is defined to have a minimum of 500 ms. However, for the <u>very first</u> day trend data set it's expected to set 1000 ms or higher, because else the function run might fail.</i>

ModBus & SCPI

Nr.	Command	Description
21	00 10 2E EA 00 06 0C 00 00 00 02 6D 3A 74 0D 00 00 05 DC E4 C3	Write 2 nd day trend data set: Irradiation: 800 W/m ² (0x6D3A) Temperature: 28°C (=0x740D) Dwell time: 1500 ms (=0x000005DC)
...		Write further data sets, a total of 500
519	00 10 2E EA 00 06 0C 00 00 01 F4 A3 D6 7F FF 00 00 4E 20 34 AF	Write 500. day trend data set: Irradiation: 1200 W/m ² (=0xA3D6) Temperature: 35°C (=0x7FFF) Dwell time: 20000 ms (=0x000034AF)

Control, also during simulation run

Nr.	Command	Description
520	00 05 2E E6 FF 00 65 34	Start simulation -> the simulation will stop automatically after the time that results from the total of dwell times in all written data sets



During the simulation, the index counter in register 12010 is updated with every next day trend point on the curve. It can be read and used to determine at which point the curve has been stopped due to an unexpected error, such as a device alarm.

Analysis after simulation end

Nr.	Command	Description
521	00 03 2E F4 00 02 8D 00	Read number (n) of recorded data sets. This number is not related to the number of day trend data sets in use. This feature records a new data set every 100 ms. Depending on the total simulation time, the record buffer could fill (max. 16 h record time) and overwrite existing data. It may become necessary to calculate the total simulation time from the day trend data sets and start reading the recorded data during simulation, then clearing the buffer and later read the rest of data.
522	00 10 2E F6 00 02 04 00 00 00 01 6C 5C	Select first data set (index 1) for reading
523	00 03 2E F8 00 08 CD 04	Read data from data set (index) 1
...		Read further n-1 data sets:

5. SCPI protocol

SCPI is an international standard for a clear text based command language. Details about the standard itself can be found on the internet.

5.1 Format of set values and actual values

In the SCPI command language **real values** are used, with or without unit. It means, if you wanted to set a current of 177.5 A you would use the simple command **CURR 177.5** or, with unit, CURR 177.5 A. Below you will find more detailed information about the available commands and their syntax.

5.2 Syntax

Specification according to „1999 SCPI Command reference“.

Following syntax formats can occur in commands and/or responses:

Values	This numeric value corresponds to the value in the display of the device and depends on the nominal values of the device. Rules: - The value must be sent after the command and separated by a space - Instead of a numeric value you can also use:	
	MIN	corresponds to the minimum value of the parameter
	MAX	corresponds to the maximum value of the parameter
<NR1>	Numeric values without decimal place	
<NR2>	Numeric values with decimal place (floating point)	
<NR3>	Like <NR2>, but with multiplier (kilo, milli etc.)	
<NRf>	<NR1> or <NR2> or <NR3>, negative values supported	
Unit	V (Volt), A (Ampere), W (Watt), OHM, s (Seconds)	
<CHAR>	0..255: Decimal value	
<+INT>	0..32768: Positive integer value (output from device)	
<B0>	1 or ON: Function is/will be activated 0 or OFF: Function is/will be deactivated	
<B1>	NONE: manual operation active, switching to remote control possible LOCAL: local (manual) operation only, reading of data possible REMOTE: device is in remote control	
<ERR>	Error with number (-800 bis 399) and description	
<SRD>	String data, various formats: - IP address as number string with dots as separator, for example „192.168.0.2“ - Key words, for example AUTO or OFF	
<Time>	[s]s.[s][s][s][s][s][s] / Default format is seconds (s.s)	
;	The semicolon is used separate multiple commands within one message	
:	The colon separates the SCPI keywords (main system, subsystems)	
[]	Lowercase letters and the content of square brackets are optional	
?	The question mark identifies a message as query. A query can be combined with a control message (command concatenation). Note, that it's required to wait for the response of the query before the next control message can be sent.	
->	Response from device	

5.2.1 Coupled commands

It's possible to couple, i.e. concatenate up to 5 commands in one message. The commands must then be separated by a semicolon (;). Example:

VOLT 80;CURR 20;POW 3kW

The command in the string are processed from left to right, so the order of commands is important to achieve correct results. When querying multiple values or parameters at once, the returned string is also in coupled format, with the queried returns separated by semicolons.

ModBus & SCPI

5.2.2 Upper and lower case

SCPI uses upper case commands by default, though the device also accept lower case form.

5.2.3 Long form and short form

SCPI commands have a long form and a short form. The short form (eg. SOUR) and the long form (eg. SOURCE) can be used arbitrarily. To distinguish both forms, the commands as described in the following sections are written partly in upper case (indicates short form), partly in lower case letters (indicates the additional part of the long form).

5.2.4 Termination character

Some interfaces like require to attach a termination character to the message, but others don't, such as USB. There the termination character is optional and used in order to maintain compatibility between several different interfaces in control softwares which use SCPI. Devices with installed option 3W, means a GPIB interface, absolutely require to send this character or else a timeout error will occur.

Supported termination character(s): **0xA** (LF, line feed)

*When using SCPI over Ethernet some series require to attach the above defined termination character to the end of every message **since a specific KE firmware version**. Overview:*

Series	Firmware version
ELR 9000 / ELR 9000 HP	KE 2.22
PSI 9000 2U - 24U	KE 2.22
PSB 9000 / PSB 9000 Slave	KE 2.22
PSBE 9000	KE 2.22
PSE 9000	KE 2.22

It means that a firmware update from a version lower than above listed to the above listed or higher can void the function of custom software!

5.2.5 Errors

Errors in terms of SCPI are only communication errors. According to the standard, devices using SCPI do not return errors immediately. They have to be queried from the device. The query can occur directly with the error command (see 5.4.5.4) or by first reading the signal bit "err" from the STB register (see „5.4.2. Status registers“).

The error format is defined by the standard and is made of a string containing a number (the actual error code) and an explanatory text. Following errors strings can be generated by the device:

Error code / error text	Description
0, "No error"	No error
-100, "Command error"	Command unknown
-102, "Syntax error"	Command syntax wrong
-108, "Parameter not allowed"	A command was sent with a parameter though the command doesn't use parameters
-200, "Execution error"	Command could not be executed
-201, "Invalid while in local"	Control command could not be executed, because device is in LOCAL mode
-220, "Parameter error"	Wrong parameter used
-221, "Settings conflict"	Command could not be executed because of the condition of the device (being in MENU etc.)
-222, "Data out of range"	Parameter could not be set because it exceeded a limit
-223, "Too much data"	Too many parameters per command or too many commands at once
-224, "Illegal parameter value"	A parameter not specified for the command has been sent
-999, "Safety OVP"	Alarm Safety OVP (only available with specific models) has been triggered (see device manual). It requires to power cycle the device.

5.3 Examples for a first start

5.3.1 Ping

It's always recommended to ping a device first, in order to test if it responds at all. With SCPI, this is usually done by querying the identification string:

Protocol	Command
SCPI	*IDN?

As an immediate response, the device might send, for example:

Protocol	Response
SCPI	EA Elektro-Automatik GmbH&Co.KG, EL 9080-340, 1240210002, V2.14 14.05.2018 V2.24 04.06.2018 V1.6.5

5.3.2 Switch to remote control or back to manual control

Before you can remotely control a device, you need to switch it to remote control by sending the dedicated command. Also see the SCPI command description below.



The device will never switch to remote control automatically and can not be remotely controlled without being in this condition. Reading status and values is but always possible.



The device will never exit remote control automatically, unless it's switched off or the AC supply is otherwise interrupted. Remote control can be left by a certain command. It then switches back to manual control.

Switching to remote control may be inhibited by several circumstances and is usually indicated by an error message:

- Condition „**Local**“ is active (check the display or control panel on the front of your device), which will prevent any remote control
- The device is already remotely controlled by another interface
- The device in setup mode, means the user has accessed the setup menu and not left it yet

► How to switch a device to remote control:

1. If you are using SCPI command language, send a text command (the space is required):
SYST:LOCK_1 or SYST:LOCK_ON

Leaving remote control can be done in two ways: using the dedicated command or by switching the device to “**Local**” condition. We will consider the first option, because this is about programming.

► How to exit remote control:

1. If you are using SCPI command language, send a text command (the space is required):
SYST:LOCK_0 or SYST:LOCK_OFF

5.4 Command groups

Command groups are related to specific features of a device. Not all series feature the same number of commands, which is due to a different number of features within a series. Every command below will indicate to which series it's compatible. Example:

ELR9	PS9	PSI9	PSI5
✓	—	✓	—

For the abbreviations see „1.1.2. Validity“, whereas



means, the command or the command group (entirely or partly) is supported by the device series.



means, the command or the command group is not supported by the device series.

5.4.1 Standard IEEE commands

In relation to the old interface standards GPIB and IEEE 488, some of the standard commands have been implemented. They are supported in all devices which feature SCPI command language.

5.4.1.1 *CLS

Clears the error queue and the status byte (STB).

5.4.1.2 *IDN?

Returns the device identification string, which contains following information, separated by commas:

1. Manufacturer
2. Model name
3. Serial number
4. Firmware version(s) (in case there are several, these are separated by a space)
5. User text (arbitrary user-definable text, as definable with SYST:CONFIG:USER:TEXT)

5.4.1.3 *RST

When sent, this will set the device to a defined state, except remote control is denied by the device:

1. Switch to remote control (same as SYST:LOCK 1)
2. Set DC input/output to off
3. Clear alarm buffer
4. Clear status registers to default condition (QUESTIONable Event, OPERATION Event, STB)

5.4.1.4 *STB?

Reads the SStatus Byte register. The signal run of the various device conditions and events is illustrated in the register model below. The STB bits in particular:

Bit 0: not used

Bit 1: not used

Bit 2: *err*, Error Queue --> one or several error in the error buffer. By reading the error buffer or sending *CLS it's flushed and the bit *err* is reset

Bit 3: *ques*, Questionable Status Register is active (one or several events have occurred)

Bit 4: not used

Bit 5: not used

Bit 6: not used

Bit 7: *oper*, Operation Status Register is active (one or several events have occurred)

5.4.2 Status registers

Not all device conditions and alarms can be read with dedicated SCPI commands. As an alternative, the remaining device-related information are grouped in status registers. Using regular polling, the status byte (STB) can be a starting point for reading the device status. It tells what status register has recorded at least one event. Apart from that, the other status registers could also be polled directly. The difference then would be, that the user would have to find out, what bits in the register have changed, by comparing the most recent value with an older value. The bits in the status byte register will do that job for you. If they remain 0, nothing has happened.

Once a bit in the STB signalises, that there was an event recorded in QUES or OPER register, you could read the corresponding event register of OPER and QUES, in order to find out which bits have changed in the COND register.

Register model:

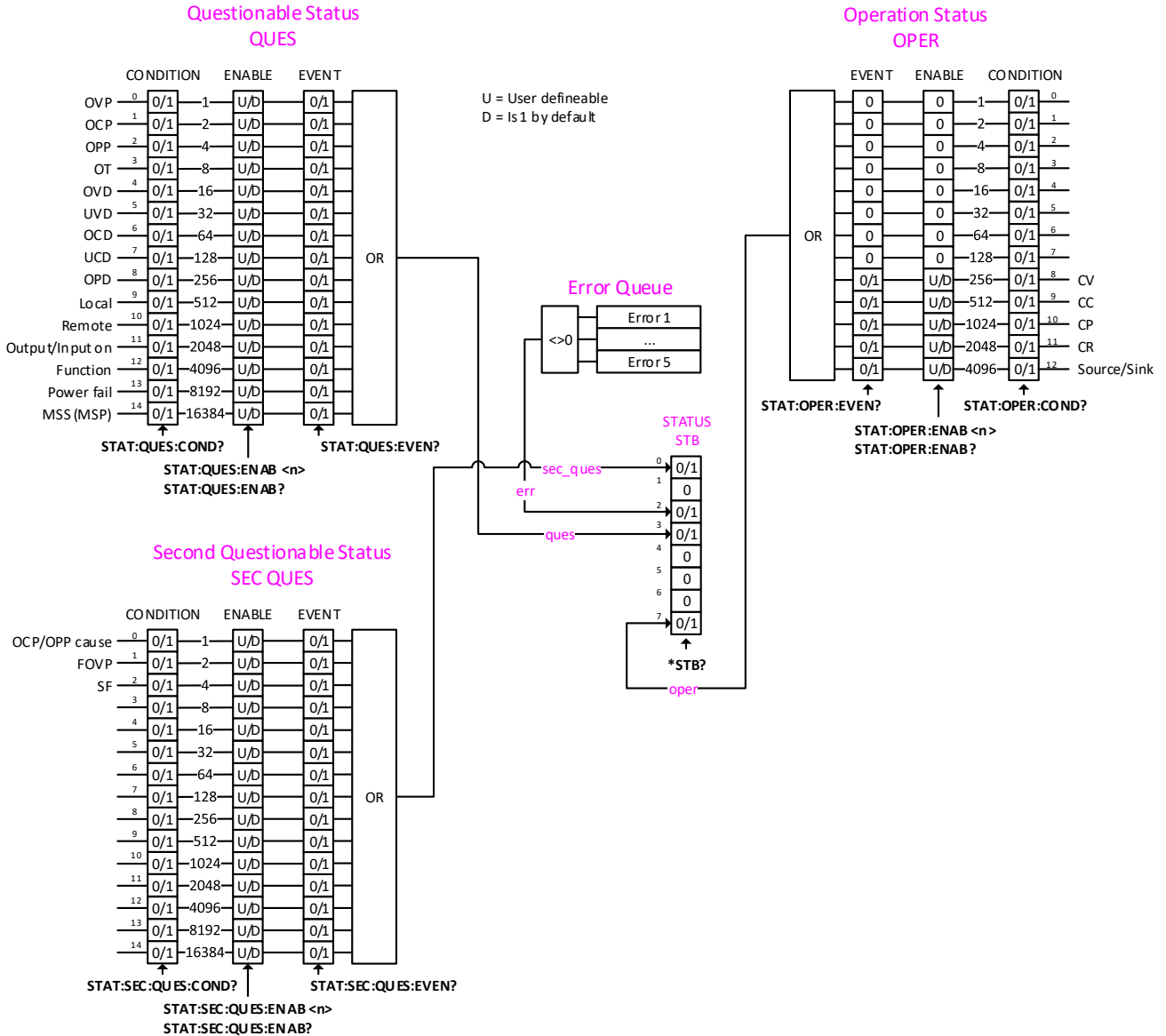

Events recorded in the event registers `STAT:QUES:EVENT` and `STAT:OPER:EVENT` only record PTRs (positive transition), i. e. the changeover from 0 to 1.



The various device series differ in the number of statuses and events they can signalise to the user in the registers. Rule of thumb: if there is no feature "UVD" (undercurrent detection) specified for your device, it won't be present as signal in the status registers, too. Which ones of the status register signals, in relation to certain features, are available for your particular device is specified in the device operating guide.



Device alarms like OVP are signalled in the subregisters *CONDITION* and *EVENT*. They have to be acknowledged separately using commands *SYST:ERR?* or *SYST:ERR:ALL?*, which is considered as alarm acknowledgement and will clear the corresponding bit in *CONDITION*, but only if the alarm condition is not present anymore. Acknowledged alarms can later only be read from the device in form of an alarm counter (where featured and only available from a certain KE firmware version). It's recommended to regularly poll alarms from the device and to query *STAT:QUES?* prior to *SYST:ERR?*.



Only with 60 V models (series *PSB 9000 / PSBE 9000* and *PSI 9000 WR*): the additional alarm "Safety OVP" (*SOVP*, see device manual), is not signalled separately, but as a combination of alarm *PF* (*STAT:QUES* Bit 13) and alarm *OVP* (*STAT:QUES* Bit 0). Additionally, the unerasable error -999 is put into the error queue. *SOVP* can only be acknowledged by power-cycling the device.

5.4.2.1 STATus:QUESTionable?

Reads the Questionable status *EVENT* or *CONDITION* register. The device will return a 16 bit value, which represents device information as defined in the register model in 5.4.2.

Query form 1: STATus:QUESTionable:CONDition?

Query form 2: STATus:QUESTionable:EVENT?

Query form 3: STATus:QUESTionable?

Examples:

STAT:QUES? --> 3072 Reads the event register. This value tells, that bits 10 and 11 are set and according to the register model this is interpreted as "remote control = active" and "DC input/output = on".

STAT:QUES:COND? Reads the condition register of the questionable status register. The value contains the current snapshot of a number of status bits.

5.4.2.2 STATus:QUESTionable:ENABLE_<NR1>

This command sets or read the Enable register of the Questionable status register. The Enable register is a filter that enables all or single bits to signalise an event to the status byte *STB*. By default, all bits of the Enable register are set. In case you want to ignore certain bits, you just need to add the values of the remaining bits and send the value to the Enable register.

Query form: STATus:QUESTionable:ENABLE?

Value range: 0...32767

Example:

STAT:QUES:ENAB_3072 Sets the enable register of the questionable status registers to 3072 and enables the bits „OVP“, „OT“, „Remote“ and „Input/Output on“ for event reporting to *STB*.

5.4.2.3 STATus:OPERation?

Reads the Operation status *EVENT* or *CONDITION* register. The device will return a 16 bit value, which represents device information as defined in the register model in 5.4.2.

Query form 1: STATus:OPERation:CONDition?

Query form 2: STATus:OPERation:EVENT?

Query form 2: STATus:OPERation?

Examples:

STAT:OPER? --> 256 Reads the operation register (identical to *:EVENT?*). A possible response would be a value of 256, which tells, that bit 8 is set and according to the register model bit 8 signalises, that „CV“ (constant voltage regulation) is active.

STAT:OPER:COND? Reads the condition register of the operation status registers.

5.4.2.4 STATus:OPERation:ENABle_<NR1>

Sets or reads the Enable register of the Questionable status register. The Enable register is a filter. It enables single or all bit of the condition registers to change the corresponding bit in the event register. This also impacts the summary bit in the status byte STB. By default, all bits of the Enable register are set to 1. If you want to use only some specific bits to be left through, just add their bit values (see register model) and send the total to the Enable register.

Query form: STATus:OPERation:ENABle?

Value range: 0, 256...3840

Example:

STAT:OPER:ENAB_1792 Sets the Enable register of the Operation register to value 1792 and enables bits „CV“, „CC“ and „CP“ for reporting events to the STB.

5.4.2.5 Further status register

With the introduction of PSB 10000, ELR 10000 and PSI 10000 series in 2019, the requirement for more alarm bits led to the addition of a second questionable register which has these new alarms connection. See the register model above. There are also additional command for that new register which have the same use and function as the commands described in 5.4.2.1 to 5.4.2.4. For details refer to these section. It also means, that so far only these three series support the extra commands:

STATus:SECond:QUEStionable?

STATus:SECond:QUEStionable:ENABle?

STATus:SECond:QUEStionable:ENABle_<NR1>

STATus:SECond:QUEStionable:CONDition?

STATus:SECond:QUEStionable:EVENT?

5.4.3 Set value commands



All set values (U, I, P, R), which have dedicated single commands and which you can send to the device during remote control, are not only limited by the maximum, i.e. nominal values of your particular device model, but additionally limited by those adjustment limits "Limits" that you can define for manual adjustment!

5.4.3.1 [SOURCE:]VOLTage_<NRf>[Unit]

Sets the input resp. output voltage limit of the device within a certain range, which is either defined by adjustment limits ("Limits", where featured) or is 0...102% nominal value, or reads the last setting. Alternatively, parameters MIN or MAX can be used to instantly set the voltage to the adjustable MINimum or MAXimum.

Query form: [SOURCE:]VOLTage?

Value range: <NRf> = 0...1.02 * nominal voltage (according to technical specs)

Examples:

VOLT 12 Absolute short form. Sets 12 V.

SOUR:VOLTAGE_24.5V Mixed form short/long, with unit. Sets 24.5 V, unless the voltage adjustment range has been limited otherwise.

SOURCE:VOLTAGE_MIN Sets the voltage to the defined minimum, usually 0 V.

5.4.3.2 [SOURCE:]CURRent_<NRf>[Unit]

Sets the input resp. output current limit of the device within a certain range, which is either defined by adjustment limits ("Limits", where featured) or is 0...102% nominal value, or reads the last setting. Alternatively, parameters MIN or MAX can be used to instantly set the current to the adjustable MINimum or MAXimum.

Query form: [SOURCE:]CURRent?

Value range: <NRf> = 0...1.02 * nominal current (according to technical specs)

Example:

CURR_170 Absolute short form. Sets 170 A.

SOUR:CURRENT_45.3A Mixed form short/long, with unit. Sets 45.3 A, unless the adjustment range of the current has been limited otherwise.

SOURCE:CURRENT_MAX Sets the current to the defined maximum, which is either 102% of the rated current of the device or, if existing for the particular device, to the value of adjustment limit "I-max" (also see 5.4.8).

5.4.3.3 [SOURCE:]POWer_<NRf>[Unit]

Sets the input resp. output power limit of the device within a certain range, which is either defined by adjustment limits ("Limits", where featured) or is 0...102% nominal value, or reads the last setting. Alternatively, parameters MIN or MAX can be used to instantly set the power to zero (MINimum) or MAXimum.

Query form: [SOURCE:]POWer?

Value range: <NRf> = 0...1.02 * nominal power (according to technical specs)

Examples:

POW_3000 Absolute short form. Sets 3000 W, unless the power adjustment range has been limited otherwise.

SOUR:POWER_3.5kW Mixed form short/long, with unit and magnitude Kilo. Sets 3.5 kW resp. 3500 W, unless the adjustment range of the power has been limited otherwise.

SOURCE:POWER_MIN Sets the power to the defined minimum, which is usually 0 W.

5.4.3.4 [SOURCE:]RESistance_<NRf>[Unit]

ELR9	ELR5	PS9	PSI9	PSI5	PSE	DT	PST	PSIT	EL3	PSB	PSBE	PS3
✓	–	–	✓	–	–	✓	–	✓	✓	✓	–	–

With electronic load devices, this command will set the input resistance value in Ohm within a defined range, as it can be adjusted on the front panel. Power supplies with internal resistance feature use this value to simulate an internal resistor in series to the output, where the output voltage differs from the adjusted value by an amount that calculates from the adjusted resistance value and actual output current. The way of setting the resistance value on both device types is identical. The adjustable range can be limited with an upper adjustment limit. Alternatively, parameters MIN or MAX can be used to instantly set the resistance to the adjustable MINimum or MAXimum.

Query form: [SOURCE:]RESistance?

Value range: <NRf> = Min. resistance...max. resistance, according to technical specs

Examples:

RES? Absolute short form. Queries the currently set resistance value.

SOUR:RESISTANCE_10 Mixed form short/long. Sets 10 Ω.

SOURCE:RES_MIN Sets the resistance to the minimum defined for the particular device model.

5.4.3.5 SINK:CURRENT_<NRf>[Unit]

ELR9	ELR5	PS9	PSI9	PSI5	PSE	DT	PST	PSIT	EL3	PSB	PSBE	PS3
–	–	–	–	–	–	–	–	–	–	✓	✓	–

This command is only available for the bidirectional devices of series PSB 9000 and sets the set value of current for the so-called sink mode, which is separate from the one of the source mode (see 5.4.3.2).

Contrary to the "normal" CURRent command, the main system SINK is not optional, because the device could else not distinguish. The adjustment limits also apply, but for this separate set value there are also the separate limits "Sink: I-min" and "Sink: I-max", as adjustable on the HMI, as well as the corresponding commands (see 5.4.8). Alternatively, parameters MIN or MAX can be used to instantly set the current to the adjustable MINimum or MAXimum.

Query form: SINK:CURRENT?

Value range: <NRf> = I-min...I-max

Examples:

SINK:CURR_120 Unless the adjustment limits restrict the setting, this will set the set value of current for the sink mode of a PSB 9000 to 120 A. This value can only become effective when the device changes into sink mode.

SINK:CURR_MIN Set the sink mode set value of current to the level as defined by I-min.

5.4.3.6 SINK:POWER_<NRf>[Unit]

ELR9	ELR5	PS9	PSI9	PSI5	PSE	DT	PST	PSIT	EL3	PSB	PSBE	PS3
–	–	–	–	–	–	–	–	–	–	✓	✓	–

This command is only available for the bidirectional devices of series PSB 9000 and sets the power set value for the so-called sink mode, which is separate from the one of the source mode (see 5.4.3.3).

Contrary to the "normal" POWER command, the main system SINK is not optional, because the device could else not distinguish. The adjustment limits also apply, but for this separate set value there is also the separate limit "Sink: P-max", as adjustable on the HMI, as well as the corresponding command (see 5.4.8). Alternatively, parameters MIN or MAX can be used to instantly set the power to the adjustable MINimum or MAXimum.

Query form: SINK:POWER?

Value range: <NRf> = 0...P-max

Examples:

SINK:POW_4500 Unless the adjustment limit P-max restricts the setting, this will set the power for the sink mode of a PSB 9000 to 4500 W. This value can only become effective after the device has switched to sink mode.

SINK:POWER_MIN Sets the power to 0 W.

5.4.3.7 SINK:RESistance_<NRf>[Unit]

ELR9	ELR5	PS9	PSI9	PSI5	PSE	DT	PST	PSIT	EL3	PSB	PSBE	PS3
-	-	-	-	-	-	-	-	-	-	✓	-	-

This command is only available for the bidirectional devices of series PSB 9000 and sets the resistance set value for the so-called sink mode, which is separate from the one of the source mode (see 5.4.3.4).

Contrary to the "normal" RESistance command, the main system SINK is not optional, because the device could else not distinguish. The adjustment limits also apply, but for this separate set value there is also the separate limit "Sink: R-max", as adjustable on the HMI, as well as the corresponding command (see 5.4.8). Alternatively, parameters MIN or MAX can be used to instantly set the resistance to the adjustable MINimum or MAXimum.

Query form: SINK:RESistance?

Value range: <NRf> = min. adjustable resistance (see technical specs)...R-max

Examples:

SINK:RESISTANCE_MIN Sets the resistance set value for the sink mode of a PSB 9000 device to minimum as defined by the technical specifications, which varies from model to model. The ratings (or nominal values) can be queried from the device with further commands.

5.4.4 Measuring commands

Actual values, as returned by the measuring commands, are the DC input resp. output values as they are present in the moment they are queried. They are not necessarily identical to the corresponding set values. Your device constantly measures the actual values and returns the last snapshot when queried.

5.4.4.1 MEASure:[SCALar:]VOLTage[:DC]?

Queries the device to return the last measured DC input resp. output voltage value in Volt.

Example:

MEAS:VOLT?

Absolute short form. Queries the actual voltage. A response, which should be instantly coming from the device, will return a value between 0% and max. 125% of nominal device voltage, like for example "43.50 V". The number of decimal places in the returned value will be identical to the value format in the device display and varies from model to model.

5.4.4.2 MEASure:[SCALar:]CURREnt[:DC]?

Queries the device to return the last measured DC input resp. output current value in Ampere.



With devices of series PSB 9000 and PSBE 9000, the returned actual value could be either from source or sink mode. If the value is negative, it belongs to sink mode.

Example:

MEASURE:CURRENT?

Queries the actual current only. A response, which should be instantly coming from the device, will return a value between 0% and max. 125% of nominal device current, for example "100.1 A". The number of decimal places in the returned value will be identical to the value format in the device display and varies from model to model.

5.4.4.3 MEASure:[SCALar:]POWer[:DC]?

Queries the device to return the last calculated DC input resp. output power value in Watts.



With devices of series PSB 9000 and PSBE 9000, the returned actual value could be either from source or sink mode. If the value is negative, it belongs to sink mode.

Example:

MEAS:POW?

Absolute short form. Queries the consumed (e-load) resp. supplied power (PSU). A response, which should be instantly coming from the device, will return a value between 0% and max. 125% of nominal device power, for example "2534 W". No matter how the actual power format is in the device's display, here it will always be returned in Watts.

5.4.4.4 MEASure:[SCALar:]ARRay?

Queries the device to return the last measured resp. calculated actual values of voltage, current and power (in that sequence) , separated by commas and with unit and eventually magnitude.



With devices of series PSB 9000 and PSBE 9000, the returned actual values could be either from source or sink mode. If a value is negative, it belongs to sink mode. Since only one of both modes can be active, the actual current and power would always be positive or negative at the same time.

Example:

MEAS:ARR?

Absolute short form. A response, which should be instantly coming from the device, will return three values between 0% and max. 125% of nominal device values, for example "12.5 V, 33.3 A, 420 W"

5.4.5 Status commands

Status commands are used to alter the status of the device in terms of activating remote control or switching the DC input/output, or to query the current status.

5.4.5.1 SYSTem:LOCK_<B0>

This command is used to activate remote control of a device. Basically, remote control has to be activated first before you can send any command that changes device status or value. Once remote control has been activated via one of the digital interfaces, only that interface is in charge.

The activation of remote control can be refused by the device due to several reasons. It's usually replied in form of a SCPI error which is put into the SCPI error buffer. This buffer can be read with the error command (see „5.4.5.4. SYSTem:ERRor?“).

Query form: SYSTem:LOCK:OWNer?

Value range for set: ON, OFF

Value range for query: REMOTE, NONE, LOCAL

Examples:

SYST:LOCK_ON Absolute short form. Requests the device to switch to remote control. The device then usually indicates activated remote control either by a LED or a status text in the display.

SYSTEM:LOCK:OWNER? Queries the lock owner regarding remote control. This can be used to verify whether the device has accepted the request to switch to remote control or not. It can return three different statuses:

REMOTE = Device is in remote control via any of the available interfaces

NONE = Device is not in remote control

LOCAL = Device is in LOCAL condition, which denies or interrupts remote control.

Usually actually manually on the device's front panel

5.4.5.2 INPut_<B0>

ELR9	ELR5	PS9	PSI9	PSI5	PSE	DT	PST	PSIT	EL3	PSB	PSBE	PS3
✓	✓	–	–	–	–	✓	–	–	✓	–	–	–

This command is used to switch the DC input of devices with an input, here: electronic loads, on or off. The main key word SOURCE is taken from the SCPI standard and actually does not fit an energy sinking device, but is used for that purpose.

Query form: INPut?

Value range: ON, OFF

Examples:

INP_1 Absolute short form. Switches the DC input on if remote control is active.

INPUT? Queries the condition of the DC input, which will be returned as ON or OFF. Against all expectations, the input might be switched off due to a device alarm.

5.4.5.3 OUTPut_<B0>

ELR9	ELR5	PS9	PSI9	PSI5	PSE	DT	PST	PSIT	EL3	PSB	PSBE	PS3
–	–	✓	✓	✓	✓	✓	✓	✓	–	✓	✓	✓

This command is used to switch the DC output on or off with devices that have an output, like power supplies or other sources.

Query form: OUTPut?

Value range: ON, OFF

Examples:

OUTP_1 Absolute short form. Switches the DC output on if remote control is active.

OUTPUT? Queries the condition of the DC output, which will be returned as ON or OFF. Against all expectations, the output might be switched off due to a device alarm.

5.4.5.4 SYSTem:ERRor?

This commands is used to read a single error or all errors from the device's internal SCPI error queue. This queue only contains errors in relation to commands, i.e. wrong syntax, too high values etc. It can not return any device alarm. Those are usually queried from the device by reading bits of the status registers (see „5.4.2. Status registers“). You can chose either to query the next error multiple times until it says “No error” or generally query all at once. After all errors have been read from the buffer, it will be purged.

The queue is of type FIFO (first in, first out). It means, that the first occurred error is put out first when querying them.

<u>Query form 1:</u>	SYSTem:ERRor?	Queries the last or next error
<u>Query form 2:</u>	SYSTem:ERRor:NEXT?	Queries the last or next error
<u>Query form 3:</u>	SYSTem:ERRor:ALL?	Queries all errors in the buffer (up to 5)

Example:

SYST:ERR? Absolute short form. The device replies to this query with a string that first contains an error code (see error code list) and second an error description, for example: 0,“No error“. This is returned every time no error is present or after all error have been returned.

SYSTEM:ERROR:ALL? This query will let the device return up to 5 concatenated errors in one string, separated by comma plus space.



Querying errors with SYST:ERR? also clears bits related to device alarms in register QUESTIONable (see „5.4.2. Status registers“), but only if the alarm condition is "gone". This is considered as acknowledgement by the user. Alarms that have been acknowledged this way can then not be read from the register anymore.

5.4.6 Commands for protective features

Devices from EA, like power supplies or electronic loads, feature a set of device alarms, partly for self-protection, partly for the protection of connected loads resp. sources. There is furthermore a supervision feature which can monitor DC input/output related values like voltage, current or power for exceeding adjustable limits and initiate user-definable actions like an acoustic alarm or shutdown of the DC input/output. The configuration of the supervision can be done manually in the actual user profile or by remote commands.

5.4.6.1 [SOURce:]VOLTage:PROTection[:LEVel]_<NRf>[Unit]

ELR9	ELR5	PS9	PSI9	PSI5	PSE	DT	PST	PSIT	EL3	PSB	PSBE	PS3
✓	✓	✓	✓	✓	✓	✓	✓	✓	✓	✓	✓	✓

This command is connected to the adjustable value “OVP” (overvoltage protection). The value is adjustable between 0 and 110% nominal device voltage for most series, except for all EL 9000 series where it's only 0...103% (in doubt, check the technical specifications in the user manual). It defines a threshold where the device switches the DC input/output off, no matter if the device has generated a voltage higher than this threshold or any outside source. When controlling a source, i.e. power supply, this feature usually serves to protect the connected load from overvoltage and thus damage. This can occur if the output voltage is accidentally adjusted to a dangerous level.

A sink, i.e. an electronic load, can not be protected from overvoltage from outside, though it will switch off the DC input at this threshold.

Query form: [SOURce:]VOLTage:PROTection[:LEVel]?

Value range: 0...1.1* resp. 1.03 * nominal voltage of the device

Examples:

VOLT:PROT_88 Absolute short form. Sets the OVP threshold to 88 V. At a model with 80 V nominal voltage, this is 110% of the maximum voltage and the maximum OVP value (not with EL 9000 series).

5.4.6.2 [SOURce:]CURRent:PROTection[:LEVel]_<NRf>[Unit]

ELR9	ELR5	PS9	PSI9	PSI5	PSE	DT	PST	PSIT	EL3	PSB	PSBE	PS3
✓	✓	✓	✓	✓	✓	✓	✓	✓	✓	✓	✓	✓

This command is connected to the adjustable value “OCP” (overcurrent protection, see SETTINGS menu on the device front panel). The value is adjustable between 0 and 110% nominal device current. It defines a threshold where the device switches the DC input/output off. With sinks, like an electronic load is one, it usually suffices to protect the source from too high current consumption. Once the input/output current reaches the threshold, the device will instantly switch the DC input/output off. The threshold is only effective if it's adjusted to a lower value than the input/output current, because else the device would just limit the current, but not switch off. If current value and overcurrent protection are adjusted to the same value, the OCP has priority and will switch off rather than limit.

Query form: [SOURce:]CURRent:PROTection[:LEVel]?

Value range: 0...1.1 * nominal current of the device

Example:

CURR:PROT_100 Absolute short form. Sets the OCP threshold to 100 A.

5.4.6.3 [SOURce:]POWEr:PROTection[:LEVel]_<NRf>[Unit]

ELR9	ELR5	PS9	PSI9	PSI5	PSE	DT	PST	PSIT	EL3	PSB	PSBE	PS3
✓	✓	✓	✓	✓	✓	✓	✓	✓	✓	✓	✓	✓

This command is connected to the adjustable value “OPP” (overpower protection, see SETTINGS menu on the device front panel). The value is adjustable between 0 and 110% nominal device power. It defines a threshold where the device switches the DC input/output off. This feature shall help to protect a source or load from exceeding a certain power output resp. consumption, regardless of voltage and current. Once the input/output power reaches the threshold, the device will instantly switch the DC input/output off. The threshold is only effective if it's adjusted to a lower value than the input/output power, because else the device will just limit the power, but not switch off. If power value and overpower protection are adjusted to the same value, the OPP has priority and will switch off rather than limit.

Query form: [SOURce:]POWEr:PROTection[:LEVel]?

Value range: 0...1.1 * nominal power of the device

Example:

POW:PROT_1.5kW Absolute short form. Sets the OPP threshold to 1.5 kW.

ModBus & SCPI

5.4.6.4 SINK:CURRENT:PROTECTION[:LEVEL]_<NRf>[Unit]

ELR9	ELR5	PS9	PSI9	PSI5	PSE	DT	PST	PSIT	EL3	PSB	PSBE	PS3
–	–	–	–	–	–	–	–	–	–	✓	✓	–

This command is only available for the bidirectional devices of series PSB 9000 and PSBE 9000 and sets the so-called OCP threshold for the sink mode, which is separate from the OCP threshold of the source mode (see 5.4.6.2).

Contrary to the command for the source mode, the main system SINK is here not optional, because the device could else not distinguish. No adjustment limits. Alternatively, parameters MIN or MAX can be used to instantly set the threshold to the adjustable MINimum or MAXimum.

Query form: SINK:CURRENT:PROTECTION[:LEVEL]?

Value range: <NRf> = 0...1.1 * nominal current of the device

Examples:

SINK:CURR:PROT_MAX Absolute short form. Sets the OCP threshold to 110% of nominal current

5.4.6.5 SINK:POWER:PROTECTION[:LEVEL]_<NRf>[Unit]

ELR9	ELR5	PS9	PSI9	PSI5	PSE	DT	PST	PSIT	EL3	PSB	PSBE	PS3
–	–	–	–	–	–	–	–	–	–	✓	✓	–

This command is only available for the bidirectional devices of series PSB 9000 and PSBE 9000 and sets the so-called OPP threshold for the sink mode, which is separate from the OPP threshold of the source mode (see 5.4.6.2).

Contrary to the command for the source mode, the main system SINK is here not optional, because the device could else not distinguish. No adjustment limits. Alternatively, parameters MIN or MAX can be used to instantly set the threshold to the adjustable MINimum or MAXimum.

Query form: SINK:POWER:PROTECTION[:LEVEL]?

Value range: <NRf> = 0...1.1 * nominal power of the device

Examples:

SINK:POWER:PROT_3000 Sets the OPP threshold to 3000 W, if the device has at least 3000 W power rating.

5.4.7 Commands for supervision features

ELR9	ELR5	PS9	PSI9	PSI5	PSE	DT	PST	PSIT	EL3	PSB	PSBE	PS3
✓	–	–	✓	–	–	✓	–	✓	–	✓	–	–

The commands below enable the remote configuration of the supervision features (Events) of the device, related to voltage, current or power on the DC input or DC output.



With series PSB 9000 and PSBE 9000 these commands are only for supervision of the so-called source mode. For sink mode supervision see below at 5.4.7.1.

Command	Beschreibung
SYSTEM:CONFIg:UVD[?]<NRf>[Unit] SYSTEM:CONFIg:UVD:ACTIon[?]<NONE SIGNAL WARNING ALARM>	Identical to event UVD, as configurable in the device menu
SYSTEM:CONFIg:UCD[?]<NRf>[Unit] SYSTEM:CONFIg:UCD:ACTIon[?]<NONE SIGNAL WARNING ALARM>	Identical to event UCD, as configurable in the device menu
SYSTEM:CONFIg:OVD[?]<NRf>[Unit] SYSTEM:CONFIg:OVD:ACTIon[?]<NONE SIGNAL WARNING ALARM>	Identical to event OVD, as configurable in the device menu
SYSTEM:CONFIg:OCD[?]<NRf>[Unit] SYSTEM:CONFIg:OCD:ACTIon[?]<NONE SIGNAL WARNING ALARM>	Identical to event OCD as configurable in the device menu
SYSTEM:CONFIg:OPD[?]<NRf>[Unit] SYSTEM:CONFIg:OPD:ACTIon[?]<NONE SIGNAL WARNING ALARM>	Identical to event OPD, as configurable in the device menu

The :ACTIon can have following parameters (also see the device's operation guide):

NONE = Event inactive, no supervision

SIGNAL = As soon as the event occurs, a status text is presented in the status field of the device display resp. a bit in the Questionable Register (STAT:QUES?) is set (see „5.4.2. Status registers“). The bit indicates, that a specific event has occurred. This can be used to record the event.

WARNING = As soon as the event occurs, a warning pop-up is presented in the device display resp. a bit in the

ModBus & SCPI

Questionable Register (STAT:QUES?) is set (see „5.4.2. Status registers“). The bit indicates, that a specific event has occurred. This can be used to record the event.

ALARM = As soon as the event occurs, a warning pop-up is presented in the device display, as well as an acoustic alarm is initiated and the DC input/output is switched off resp. a bit in the Questionable Register (STAT:QUES?) is set (see „5.4.2. Status registers“). The bit indicates, that a specific event has occurred. This can be used to record the event.



The action ALARM lets the device act similar to when device alarms occur. However, device alarm still have priority. It means, that if, for example, the values OVP and OVD would be equal and the input/output voltage reaches that level, the device would initiate an OV alarm rather than an OVD event.

5.4.7.1 Further commands

ELR9	ELR5	PS9	PSI9	PSI5	PSE	DT	PST	PSIT	EL3	PSB	PSBE	PS3
–	–	–	–	–	–	–	–	–	–	✓	–	–

The below commands are only for the supervision (events) in the sink mode of series PSB 9000 and use the additional subsystem **:SINK** for distinction.

Command	Description
SYSTem:SINK:CONFig:UCD[?]<Nrf>[Unit] SYSTem:SINK:CONFig:UCD:ACTion[?]<Nrf>{NONE SIGNAL WARNING ALARM}	Identical to event setting "Sink: UCD", as configurable in the device menu
SYSTem:SINK:CONFig:OCD[?]<Nrf>[Unit] SYSTem:SINK:CONFig:OCD:ACTion[?]<Nrf>{NONE SIGNAL WARNING ALARM}	Identical to event setting "Sink: OCD" as configurable in the device menu
SYSTem:SINK:CONFig:OPD[?]<Nrf>[Unit] SYSTem:SINK:CONFig:OPD:ACTion[?]<Nrf>{NONE SIGNAL WARNING ALARM}	Identical to event setting "Sink: OPD", as configurable in the device menu

ModBus & SCPI

5.4.8 Commands for adjustment limits

Adjustment limits are additional, globally effective, adjustable limits for the set values U, I, P and R (where featured). The purpose is to narrow the standard 0...100% adjustment range and to prevent, for example, to accidentally set a too high voltage for the load. There is also the overvoltage protection (OVP), but it's generally better to block irregular set values in the first place.

In case a set value is sent to the device that would exceed an adjustment limit, no matter if too high or too low, the device will ignore it and put an error into the error queue. At the same time it's impossible to set the lower adjustment limit (:LOW) higher than the related set value or, vice versa, the upper adjustment limit.

These commands are connected to the "Limits" setting as you can adjust them in the setup menu of your device, (were featured). Refer to the device manuals for details.

Command	ELR9	ELR5	PS9	PSI9	PSI5	PSE	DT	PST	PSIT	EL3	PSB	PSBE	PS3
[SOURce:]VOLTage:LIMit:LOW[?]<NRf>[Unit] Identical to value U-min, as configurable at the device	✓	✓	✓	✓	—	✓	✓	✓	✓	✓	✓	✓	✓
[SOURce:]VOLTage:LIMit:HIGH[?]<NRf>[Unit] Identical to value U-max, as configurable at the device	✓	✓	✓	✓	—	✓	✓	✓	✓	✓	✓	✓	✓
[SOURce:]CURRent:LIMit:LOW[?]<NRf>[Unit] Identical to value I-min, as configurable at the device	✓	✓	✓	✓	—	✓	✓	✓	✓	✓	✓	✓	✓
[SOURce:]CURRent:LIMit:HIGH[?]<NRf>[Unit] Identical to value I-max, as configurable at the device	✓	✓	✓	✓	—	✓	✓	✓	✓	✓	✓	✓	✓
[SOURce:]POWER:LIMit:HIGH[?]<NRf>[Unit] Identical to value P-max, as configurable at the device	✓	✓	✓	✓	—	✓	✓	✓	✓	✓	✓	✓	✓
[SOURce:]RESistance:LIMit:HIGH[?]<NRf>[Unit] Identical to value R-max, as configurable at the device	✓	✓	—	✓	—	—	✓	—	✓	✓	✓	—	—
SINK:CURRent:LIMit:LOW[?]<NRf>[Unit] Identical to value "Sink: I-min", as configurable at the device	—	—	—	—	—	—	—	—	—	—	✓	✓	—
SINK:CURRent:LIMit:HIGH[?]<NRf>[Unit] Identical to value "Sink: I-max", as configurable at the device	—	—	—	—	—	—	—	—	—	—	✓	✓	—
SINK:POWER:LIMit:HIGH[?]<NRf>[Unit] Identical to value "Sink: P-max", as configurable at the device	—	—	—	—	—	—	—	—	—	—	✓	✓	—
SINK:RESistance:LIMit:HIGH[?]<NRf>[Unit] Identical to value "Sink: R-max", as configurable at the device	—	—	—	—	—	—	—	—	—	—	✓	✓	—

5.4.9 Commands for master-slave operation

ELR9	ELR5	PS9	PSI9	PSI5	PSE	DT	PST	PSIT	EL3	PSB	PSBE	PS3
✓	–	–	✓	–	✓	–	–	–	–	✓	✓	–

The commands, as listed below, are used to remotely configure and control the master-slave mode (short: MS). The commands are connected to the related settings in the device setup menu. For details about MS refer to the device's operation manual.



Configuration and control require a certain procedure. It applies generally:

- Configuration should always be first, but can also be done on the device's front panel, so that after activating remote control the master-slave operation can instantly start

The commands in the tables below are listed in the sequence they should be used (top to bottom).

5.4.9.1 Configuration commands

The configuration of MS can be skipped if already done manually at the device's HMI or formerly in remote control and nothing has changed.

Command	Description
SYSTem:MS:ENABLe_{ON OFF}	Enables (ON) or disables (OFF) master-slave (MS) mode
SYSTem:MS:ENABLe?	Queries, whether the MS is enabled or not
SYSTem:MS:LINK_{MASTER SLAVE} SYSTem:MS:LINK?	Defines or queries the role of the device in the MS system: MASTER = Device will be master unit SLAVE = Device will be slave unit
SYSTem:MS:INITialisation	Starts the MS initialisation with the given settings. Also refer to the devices's operating manual. After a successful initialisation, the MS mode can be controlled with further commands. To test if the init has been successful, the next command can be used:
SYSTem:MS:CONDition?	Queries the result of a former MS init. Possible return values: INIT = Init was successful NO INIT = Init was not successful An init is also successful if there is only a master. In order to find out whether you have a complete MS system available or not, you would have to query the number of initialised units from the master with command SYST:MS:UNITs? (see below). Any value other than 0 means, the MS system is initialised and available for control.
SYSTem:MS:UNITs?	Queries the number of units that have been initialised successfully. The number can differ from the expected value, if the master did not initialise one or multiple slaves due to any reason. If only the master has initialised itself, the command will return a 1. <div style="border: 1px solid black; padding: 5px; margin-top: 10px;"> <i>Depending on the KE firmware installed on your device, the returned value may not include the master itself as an initialized device.</i></div>
SYSTem:SHARe:LINK_{SLAVE} SYSTem:SHARe:LINK?	This command is only used with electronic loads in two-quadrants operation (2Q) where they are supposed to be slaves on the Share bus, even if one load unit is master of a master-slave system of loads This only works if <ul style="list-style-type: none"> • the device is already set to MASTER for master-slave and • master-slave mode is activated and • the device is an electronic load, else the device will generate a "Settings conflict" error. <div style="border: 1px solid black; padding: 5px; margin-top: 10px;"> <i>This command is not valid for devices of series PSB 9000 and PSBE 9000, because these devices are actually 2Q system in itself and are usually not Share bus connected to other series like PSI or ELR.</i></div>
SYSTem:MS:TERMination_{ON OFF} SYSTem:MS:TERMination?	Only supported by series PSB 10000, ELR 10000 and PSI 10000. This command is used to activate/deactivate the digital switch for the termination resistor on the master-slave bus.

ModBus & SCPI

Command	Description
SYSTEM:MS:BIAS_{ON OFF} SYSTEM:MS:BIAS?	Only supported by series PSB 10000, ELR 10000 and PSI 10000. This command is used to activate/deactivate the digital switch for the additional BIAS resistors on the master-slave bus.

5.4.9.2 Other MS commands

Since KE firmware 2.20 (all 9000 series with master-slave feature) the rated values of a master-slave system are queried using the regular commands for nominal value queries, as listed in 5.4.10. These also allow querying the total resistance of an MS system. The below listed commands thus might not be supported anymore by your device.

Command	Description
SYSTEM:MS:NOMinal:VOLTage?	Queries the total voltage of the initialised MS system. The voltage of a MS system will increase in a series connection, compared to a single unit. Series connection is only allowed for power supplies
SYSTEM:MS:NOMinal:CURREnt?	Queries the total current of the initialised MS system. The current of a MS system will increase on a parallel connection, compared to a single unit
SYSTEM:MS:NOMinal:POWer?	Queries the total power of the initialised MS system. The power of a MS system will always increase, compared to a single unit

5.4.10 Commands for general queries

Here are commands listed that can be used to query other information from the device, which is not used so often.

Command	ELR9	ELR5	PS9	PSI9	PSI5	PSE	DT	PST	PSIT	EL3	PSB	PSBE	PS3
SYSTEM:NOMinal:VOLTage? Queries the nominal, i.e. rated input/output voltage of a single device or an initialised master-slave system	✓	✓	✓	✓	✓	✓	✓	✓	✓	✓	✓	✓	✓
SYSTEM:NOMinal:CURREnt? Queries the nominal, i.e. rated input/output current of a single device or an initialised master-slave system	✓	✓	✓	✓	✓	✓	✓	✓	✓	✓	✓	✓	✓
SYSTEM:NOMinal:POWer? Queries the nominal, i.e. rated input/output power of a single device or an initialised master-slave system	✓	✓	✓	✓	✓	✓	✓	✓	✓	✓	✓	✓	✓
SYSTEM:NOMinal:RESistance:MINimum? Queries the minimum internal resistance value of a single device or an initialised master-slave system. This value is usually not zero with electronic loads.	✓	—	—	✓	—	—	✓	—	✓	✓	✓	—	—
SYSTEM:NOMinal:RESistance:MAXimum? Queries the maximum internal resistance value of a single device or an initialised master-slave system	✓	—	—	✓	—	—	✓	—	✓	✓	✓	—	—
SYSTEM:DEvice:CLass? Queries the device class and returns a value which defines to what series the device belongs to. This is an easy way to distinguish different device series or types, like an electronic load from a power supply or battery charger. For a list of device classes see „A1. Device classes“	✓	✓	✓	✓	✓	✓	✓	✓	✓	✓	✓	✓	✓

ModBus & SCPI

5.4.11 Commands for device configuration

The commands as listed below are used to modify settings of the device configuration. The settings can be part of the current user profile (see device's operating manual). Any modification on the configuration requires activated remote control. These settings are automatically stored.

Command	ELR9	ELR5	PS9	PS19	PS15	PSE	DT	PST	PSIT	EL3	PSB	PSBE	PS3
POWER:STAGe:AFTer:REMote_{ AUTO OFF } POWER:STAGe:AFTer:REMote? Defines, how the DC input/output of the device shall be after leaving remote control. AUTO = Last condition remains OFF = DC input/output will be switched off	✓	—	✓	✓	✓	✓	✓	✓	✓	✓	✓	✓	✓
[SOURce:]VOLTage:CONTRol:SPEed_{FAST SLOW} [SOURce:]VOLTage:CONTRol:SPEed? This command is used to switch the internal voltage regulator of the power stage(s) of electronic loads or devices which can work as electronic load between FAST and SLOW (default) mode.	✓	—	—	—	—	—	—	—	—	✓	—	—	—
SYSTEM:CONFIg:INPut:REStore[?]{_}{AUTO OFF} SYSTEM:CONFIg:OUTPut:REStore[?]{_}{AUTO OFF} Defines the condition of DC input/output after the device is powered. This is connected to the device setting "DC input after power on" resp. "DC output after power on". AUTO = DC input/output will be restored to the condition it had when switching the device off the last time OFF = DC input/output will always be off	✓	✓	✓	✓	✓	✓	✓	✓	✓	✓	✓	✓	✓
SYSTEM:CONFIg:USER:TEXT_{<SRD>} SYSTEM:CONFIg:USER:TEXT? Writes or queries a user-definable text of up to 40 characters permanently to the device. This string can be used to add custom information to the unit, in order to distinguish it from other, identical models, alternatively to the serial number.	✓	✓	✓	✓	✓	✓	✓	✓	✓	✓	✓	✓	✓
SYSTEM:CONFIg:ANALog:MONitor_{DEFault EL PS ELPS PSEL COMBination} SYSTEM:CONFIg:ANALog:MONitor? Configures the monitor pins 9 (VMON) and 10 (CMON). DEFault = VMON signals actual voltage, CMON signals actual current of source or sink mode EL = Pin 10 only signals the actual current of sink mode PS = Pin 10 only signals the actual current of source mode ELPS = Pin 9 signal the actual current of sink mode, pin 10 the one of source mode PSEL = Inversion of ELPS setting COMBination = Pin 10 signals the current of source and sink mode, separating the signal range in two parts as -100%...0...100%. For more see device manual.	—	—	—	—	—	—	—	—	—	—	✓	✓	—
SYSTEM:CONFIg:ANALog:PIN6_{OT PF ALL} SYSTEM:CONFIg:ANALog:PIN6? Defines what device alarms are signaled on pin 6. OT = Pin 6 only signals OverTemperature PF = Pin 6 only signals Power Fail All = Pin 6 signals both (default)	✓	—	—	✓	—	✓	—	—	—	—	✓	✓	—

ModBus & SCPI

Command	ELR9	ELR5	PS9	PSI9	PSI5	PSE	DT	PST	PSIT	EL3	PSB	PSBE	PS3
SYSTEM:CONFIg:ANALog:PIN14_{OVP OCP OPP OVP/OCP OVP/OPP OCP/OPP ALL} SYSTEM:CONFIg:ANALog:PIN14? Defines what device alarms are signaled on pin 14. There are options to signal the three device alarms OVP , OCP and OPP separately or as combination of two or signal all (logical OR)..	✓	—	—	✓	—	✓	—	—	—	—	✓	✓	—
SYSTEM:CONFIg:ANALog:PIN15_{CONT POW} SYSTEM:CONFIg:ANALog:PIN15? Defines what status is signaled on pin 15. CONT = Regulation mode CV (default) POW = DC terminal on/off	✓	—	—	✓	—	✓	—	—	—	—	✓	✓	—
SYSTEM:CONFIg:ANALog:REFEreNce_{5 10} SYSTEM:CONFIg:ANALog:REFEreNce? Selects the voltage range for analog inputs and outputs of the analog interface. This has no effect on anything concerning digital remote control. 5 = 0...5 V range 10 = 0...10 V range (factory setting)	✓	—	✓	✓	✓	✓	✓	✓	✓	✓	✓	✓	✓
SYSTEM:CONFIg:ANALog:REMSB:LEVEl_{NORMAL INVERTED} SYSTEM:CONFIg:ANALog:REMSB:LEVEl? Determines how pin REM-SB of the analog interface (see device manual) shall be interpreted by the device: NORMAL = level and conditions as described in the manual (factory setting) INVERTED = level and conditions are interpreted as inverted	✓	—	✓	✓	✓	✓	✓	✓	✓	✓	✓	✓	✓
SYSTEM:CONFIg:ANALog:REMSB:ACTioN_{OFF AUTO} SYSTEM:CONFIg:ANALog:REMSB:ACTioN? Determines the action that is caused by using pin REM-SB of the analog interface in connection with DC input/output of the device: OFF = pin can only be used to switch the DC input/output off AUTO = pin can be used to switch off and on again, if the DC input/output was at least switched on once by pushbutton on the control panel or digital command	✓	—	✓	✓	✓	✓	✓	✓	✓	✓	✓	✓	✓
SYSTEM:CONFIg:MODE_{UIP UIR} SYSTEM:CONFIg:MODE? Selects the operation mode between U/I/P and U/I/R. Both modes are available for electronic loads and also on select power supplies. By selecting U/I/R, the adjustable resistance value (command [SOURCE:]RESistance resp. SINK:RESistance) is unlocked. Activated U/I/R mode can only be detected in the display from the resistance value being shown.	✓	—	—	✓	—	—	✓	—	✓	✓	✓	—	—
SYSTEM:COMMunicate:PROTOcol:MODBus_{ENABLE DISABLE} SYSTEM:COMMunicate:PROTOcol:MODBus? Enables or disables ModBus protocol on the device. This setting is stored. After disabling ModBus with this command, further ModBus messages are ignored, so that only SCPI commands are accepted. Only one of both protocols can be deactivated at the same time.	✓	✓	✓	✓	✓	✓	✓	✓	✓	✓	✓	✓	✓

ModBus & SCPI

Command	ELR9	ELR5	PS9	PSI9	PSI5	PSE	DT	PST	PSIT	EL3	PSB	PSBE	PS3
SYSTem:COMMunicate:TIMEout_{5...65535} SYSTem:COMMunicate:TIMEout? Defines a timeout in milliseconds (factory setting: 5 ms), a max. time that can elapse between two consecutive bytes, before the device considers the message as "completely received". For details refer to section 3.6. <i>Note: this only applies for serial interfaces (USB, RS232)</i>	✓	—	✓	✓	✓	✓	✓	✓	✓	✓	✓	✓	✓
SYSTem:ALARm:ACTion:PFail_{ AUTO OFF } SYSTem:ALARm:ACTion:PFail? Defines, how the DC input/output of the device shall be after a power fail (PF) alarm, which could be a mains blackout or similar and after which the device could continue its work automatically. AUTO = DC input/output condition before PF is restored OFF = DC input/output will be switched off (default setting)	✓	✓	✓	✓	✓	✓	✓	✓	✓	✓	✓	✓	✓
SYSTem:ALARm:ACTion:OTEMperature_{ AUTO OFF } SYSTem:ALARm:ACTion:OTEMperature? Defines, how the DC input/output of the device shall be after the device has recovered, i. e. cooled down after an overtemperature (OT) alarm. AUTO = DC input/output condition before OT is restored (default setting) OFF = DC input/output will be switched off	✓	—	✓	✓	✓	✓	✓	✓	✓	—	✓	✓	—

ModBus & SCPI

5.4.11.1 Commands for Anybus module settings

ELR9	ELR5	PS9	PS19	PS15	PSE	DT	PST	PSIT	EL3	PSB	PSBE	PS3
✓	–	–	✓	–	✓	–	–	–	–	✓	✓	–

Most of the Anybus interface modules can also be remotely configured using SCPI commands, either via USB port or even via the interface itself. These settings are always saved automatically.

Command	Description																																												
SYSTem:COMMunicate:INTerface:CODE?	Returns a value, representing a model code for the installed Anybus interface module: 5 = Profibus 21 = Ethernet 2P 9 = RS232 22 = ModBus TCP 2P 16 = CANopen 23 = Profinet/IO 2P 18 = ModBus TCP 1P 25 = CAN 19 = Profinet/IO 1P 26 = EtherCAT 20 = Ethernet 1P																																												
SYSTem:COMMunicate:INTerface:TYPE?	Queries the name of the installed Anybus interface module.																																												
SYSTem:COMMunicate:INTerface:SERial?	Queries the serial number of the installed Anybus interface module.																																												
SYSTem:COMMunicate:INTerface:ADDRess_<NR1> SYSTem:COMMunicate:INTerface:ADDRess?	Sets the Profibus address of the Profibus module IF-AB-PBUS or queries it. Allowed range: 0...125																																												
SYSTem:COMMunicate:PROFibus:ID?	Queries the Profibus ID of the device manufacturer.																																												
SYSTem:COMMunicate:PROFibus:FTAG_<SRD> SYSTem:COMMunicate:PROFibus:FTAG?	Sets or queries the Profibus/Profinet specific „function tag“, a string of up to 32 characters																																												
SYSTem:COMMunicate:PROFibus:LTAG_<SRD> SYSTem:COMMunicate:PROFibus:LTAG?	Sets or queries the Profibus/Profinet specific „location tag“, a string of up to 22 characters																																												
SYSTem:COMMunicate:PROFibus:DATE_<SRD> SYSTem:COMMunicate:PROFibus:DATE?	Sets or queries the Profibus/Profinet specific „date tag“, a date/time string of up to 40 characters																																												
SYSTem:COMMunicate:PROFibus:DESCRiption_<SRD> SYSTem:COMMunicate:PROFibus:DESCRiption?	Sets or queries the Profibus/Profinet specific „description“ tag, a string of up to 54 characters																																												
SYSTem:COMMunicate:PROFibus:NAME_<SRD> SYSTem:COMMunicate:PROFibus:NAME?	Sets or queries the Profinet specific „station name“, a string of up to 200 characters																																												
SYSTem:COMMunicate:INTerface:BAUD_<NR1> SYSTem:COMMunicate:INTerface:BAUD?	Queries or sets the bus speed, i.e. baud rate of a CANopen or RS232 interface module. The device will only save the value. This means, with value 3 being saved and CANopen installed, it will run at 100 kbps and with RS232 installed, with 19200 Baud. <table border="1" data-bbox="879 1453 1428 1834"> <thead> <tr> <th>Value</th> <th>CANopen</th> <th>CAN</th> <th>RS232</th> </tr> </thead> <tbody> <tr> <td>0</td> <td>10 kbps</td> <td>10 kbps</td> <td>2400 Bd</td> </tr> <tr> <td>1</td> <td>20 kbps</td> <td>20 kbps</td> <td>4800 Bd</td> </tr> <tr> <td>2</td> <td>50 kbps</td> <td>50 kbps</td> <td>9600 Bd</td> </tr> <tr> <td>3</td> <td>100 kbps</td> <td>100 kbps</td> <td>19200 Bd</td> </tr> <tr> <td>4</td> <td>125 kbps</td> <td>125 kbps</td> <td>38400 Bd</td> </tr> <tr> <td>5</td> <td>250 kbps</td> <td>250 kbps</td> <td>57600 Bd</td> </tr> <tr> <td>6</td> <td>500 kbps</td> <td>500 kbps</td> <td>115200 Bd</td> </tr> <tr> <td>7</td> <td>800 kbps</td> <td>1 Mbps</td> <td>-</td> </tr> <tr> <td>8</td> <td>1 Mbps</td> <td>-</td> <td>-</td> </tr> <tr> <td>9</td> <td>Auto</td> <td>-</td> <td>-</td> </tr> </tbody> </table>	Value	CANopen	CAN	RS232	0	10 kbps	10 kbps	2400 Bd	1	20 kbps	20 kbps	4800 Bd	2	50 kbps	50 kbps	9600 Bd	3	100 kbps	100 kbps	19200 Bd	4	125 kbps	125 kbps	38400 Bd	5	250 kbps	250 kbps	57600 Bd	6	500 kbps	500 kbps	115200 Bd	7	800 kbps	1 Mbps	-	8	1 Mbps	-	-	9	Auto	-	-
Value	CANopen	CAN	RS232																																										
0	10 kbps	10 kbps	2400 Bd																																										
1	20 kbps	20 kbps	4800 Bd																																										
2	50 kbps	50 kbps	9600 Bd																																										
3	100 kbps	100 kbps	19200 Bd																																										
4	125 kbps	125 kbps	38400 Bd																																										
5	250 kbps	250 kbps	57600 Bd																																										
6	500 kbps	500 kbps	115200 Bd																																										
7	800 kbps	1 Mbps	-																																										
8	1 Mbps	-	-																																										
9	Auto	-	-																																										
SYSTem:COMMunicate:CAN:BRoadcast_<NR1> SYSTem:COMMunicate:CAN:BRoadcast?	Sets the CAN broadcast ID for normal CAN communication. Allowed range: 0...2047 (11 bit) resp. 0...536870911 (29 bit)																																												

ModBus & SCPI

Command	Description
SYSTem:COMMunicate:CAN:DLC_{AUTO FILL} SYSTem:COMMunicate:CAN:DLC?	CAN data length setting for response messages from the device. AUTO = the number of data bytes in a CAN message from the device (response) varies according to the used command/register (default) FILL = the number of data bytes in a CAN message is always 8, filled with zeros
SYSTem:COMMunicate:CAN:FORMat_{BASE EXT} SYSTem:COMMunicate:CAN:FORMat?	Selects the CAN address format. BASE = 11 Bit (CAN 2.0A) (default) EXT = 29 Bit (CAN 2.0B)
SYSTem:COMMunicate:CAN:NODE_{NR1} SYSTem:COMMunicate:CAN:NODE?	Sets the CAN base ID for normal CAN communication. Allowed range: 0...2047 (11 bit) resp. 0...536870911 (29 bit)
SYSTem:COMMunicate:CAN:READ:NODE_{NR1} SYSTem:COMMunicate:CAN:READ:NODE?	Sets the CAN base ID for cyclic. Also see section 8.3.5. Allowed range: 0...2047 (11 bit) resp. 0...536870911 (29 bit)
SYSTem:COMMunicate:CAN:READ:ACTual_{NR1} SYSTem:COMMunicate:CAN:READ:ACTual?	Defines the interval (in milliseconds) for the cyclic read of the device's actual values (U, I, P) over CAN interface IF-AB-CAN. Also see section 8.3.5. Allowed parameter range: 0 or 20...5000 (0 = cyclic read for this object is deactivated)
SYSTem:COMMunicate:CAN:READ:ALIMits_{NR1} SYSTem:COMMunicate:CAN:READ:ALIMits?	Defines the interval (in milliseconds) for the cyclic read of the device's adjustment limits for U and I (with PSB/PSBE 9000: current of source mode) over CAN interface IF-AB-CAN. Also see section 8.3.5. Allowed parameter range: 0 or 20...5000 (0 = cyclic read for this object is deactivated)
SYSTem:COMMunicate:CAN:READ:BLIMits_{NR1} SYSTem:COMMunicate:CAN:READ:BLIMits?	Defines the interval (in milliseconds) for the cyclic read of the device's adjustment limits for P and R (with PSB/PSBE 9000: power and resistance of source mode) over CAN interface IF-AB-CAN. Also see section 8.3.5. Allowed parameter range: 0 or 20...5000 (0 = cyclic read for this object is deactivated)
SYSTem:COMMunicate:CAN:READ:CLIMits_{NR1} SYSTem:COMMunicate:CAN:READ:CLIMits?	Only with series PSB 9000 and PSBE 9000: Defines the interval (in milliseconds) for the cyclic read of the device's adjustment limits for I, P and R (sink mode) over CAN interface IF-AB-CAN. Also see section 8.3.5. Allowed parameter range: 0 or 20...5000 (0 = cyclic read for this object is deactivated)
SYSTem:COMMunicate:CAN:READ:SETS_{NR1} SYSTem:COMMunicate:CAN:READ:SETS?	Defines the interval (in milliseconds) for the cyclic read of the device's set values (U, I, P, R) over CAN interface IF-AB-CAN. Also see section 8.3.5. Allowed parameter range: 0 or 20...5000 (0 = cyclic read for this object is deactivated)
SYSTem:COMMunicate:CAN:READ:BSETS_{NR1} SYSTem:COMMunicate:CAN:READ:BSETS?	Only with series PSB 9000 and PSBE 9000: Defines the interval (in milliseconds) for the cyclic read of the device's set values I, P, R (sink mode) over CAN interface IF-AB-CAN. Also see section 8.3.5. Allowed parameter range: 0 or 20...5000 (0 = cyclic read for this object is deactivated)
SYSTem:COMMunicate:CAN:READ:STAT_{NR1} SYSTem:COMMunicate:CAN:READ:STAT?	Defines the interval (in milliseconds) for the cyclic read of the device's status over CAN interface IF-AB-CAN. Also see section 8.3.5. Allowed parameter range: 0 or 20...5000 (0 = cyclic read for this object is deactivated)

ModBus & SCPI

Command	Description
SYSTem:COMMunicate:CAN:SEND:NODE_<NR1> SYSTem:COMMunicate:CAN:SEND:NODE?	Sets the CAN base ID for cyclic send. Also see section 8.3.2. Allowed range: 0...2047 (11 bit) resp. 0...536870911 (29 bit)
SYSTem:COMMunicate:CAN:TERMination {ON OFF} SYSTem:COMMunicate:CAN:TERMination?	Switches the integrated CAN bus termination resistor ON or OFF

5.4.11.2 Commands for Ethernet interface settings

ELR9	ELR5	PS9	PS19	PS15	PSE	DT	PST	PSIT	EL3	PSB	PSBE	PS3
✓	✓	✓	✓	✓	✓	✓	✓	✓	✓	✓	✓	✓

The commands below are related to any Ethernet interface port, no matter if built-in or pluggable module. Some commands are only supported when an Anybus interface module is plugged.

The 2019 released series PSB 10000, PSI 10000 and ELR 10000 support to host two Ethernet interfaces with up to three ports. The built-in Ethernet port is here considered as the secondary port. It's required to switch the access to its settings before reading/writing parameters. Overview:

	ELR 5000, EL 3000 B, PS 3000 C PS 9000, PS 9000 T, PSI 9000 T, PSI 5000, PSI 9000 DT	ELR 9000, PSI 9000, PSB 9000, PSE 9000, PSBE 9000	PSB 10000, PSI 10000, ELR 10000
Primary Ethernet	featured (built-in)	Anybus (optional)	Anybus (optional)
Secondary Ethernet	-	-	featured (built-in)

Command	Description
SYSTem:COMMunicate:LAN:1SPEed[?]<{AUTO 10HALF 10FULL 100HALF 100FULL} SYSTem:COMMunicate:LAN:2SPEed[?]<{AUTO 10HALF 10FULL 100HALF 100FULL}	Only for IF-AB Ethernet modules (ETH, MBUS) Sets the communication speed of the network port(s) of Anybus Ethernet interfaces with one port (P1) or two ports (P1, P2): AUTO = Auto negotiation 10HALF = 10MBit, half duplex 10FULL = 10MBit, full duplex 100HALF = 100MBit, half duplex 100FULL = 100MBit, full duplex
SYSTem:COMMunicate:LAN:ADDRess[?]<SRD>	Queries or sets the IP address of the selected Ethernet interface. When setting the IP, the string has to be in the typical IP format like this: 192.168.0.2
SYSTem:COMMunicate:LAN:CONTRol[?]<{0...65535}	Queries or sets the TCP port of the selected Ethernet interface. Default is 5025, used for ModBus RTU or SCPI communication. Devices supporting ModBus TCP have port 502 activated and reserved by default, so 502 is illegal to be set with this command.
SYSTem:COMMunicate:LAN:DHCP[?]<{ON OFF}	Activates (=ON) or deactivates (=OFF) the DHCP functionality for the selected Ethernet interface. Default is OFF, so the IP as set with :ADDR command above is used.
SYSTem:COMMunicate:LAN:DNS1[?]<SRD> SYSTem:COMMunicate:LAN:DNS2[?]<SRD>	Queries or sets the network address of the first DNS1 of the selected Ethernet interface, plus also for the second DNS2 (only with Anybus modules).
SYSTem:COMMunicate:LAN:DOMain[?]<SRD>	Queries or sets the domain name (refer to network terminology for details). This is a simple ASCII string of up to 54 characters. The domain can be used to select and access a particular device in the network without knowing the IP address.

ModBus & SCPI

Command	Description
SYSTem:COMMunicate:LAN:GATeway[?] <SRD>	Queries or sets the gateway address of the selected Ethernet interface. Format is the same as with the IP. This address is often not used and can thus be left at the default setting.
SYSTem:COMMunicate:LAN:HOSTname[?]<SRD>	Queries or set the host name (refer to network terminology for details). This is a simple ASCII string of up to 54 characters.
SYSTem:COMMunicate:LAN:KEEPalive[?]{ON OFF}	Enables / disables the so-called "TCP keep-alive" for the selected Ethernet interface. Also see „3.7. Connection timeout“. Default setting: OFF
SYSTem:COMMunicate:LAN:MAC?	Queries the MAC of the selected Ethernet interface, when physically present.
SYSTem:COMMunicate:LAN:SMASK[?]<SRD>	Queries or sets the subnet mask of the selected Ethernet interface. Format is the same as with the IP.
SYSTem:COMMunicate:LAN:TIMEout[?]{0 5...65535}	Defines a socket connection timeout for the selected Ethernet interface. Also see „3.7. Connection timeout“. Setting this to 0 disables the timeout. Default setting: 5 seconds

The 2019 released series PSB 10000, ELR 10000 and PSI 10000 require to select between the primary (slot, Anybus module) and secondary Ethernet interface (built-in RJ45) before accessing Ethernet related settings via SCPI commands. After powering the device, the primary interface is selected by default, no matter if a module is plugged or not.

Command	Description
SYSTem:COMMunicate:LAN:INDex_{1 2} SYSTem:COMMunicate:LAN:INDex?	Temporary switch between internal port (2) and the additional port (1, default after power-up).

5.4.12 Commands for remote control of the function generator

ELR9	ELR5	PS9	PSI9	PSI5	PSE	DT	PST	PSIT	EL3	PSB	PSBE	PS3
✓	—	—	✓	—	—	✓	—	✓	—	✓	—	—



Sequence data or table data, which you can write via SCPI commands, is **not stored** in the device.

The function generator is a complex part of the whole control options of the device. It can be remotely configured and controlled by a set of SCPI commands. When operating the function manager on the control panel of the device, it requires a certain procedure of setup before getting to the actual starting point. The single commands can not enforce that procedure, so it's up to the user to use them in the correct sequence. What to do:

1) Select the type of generator

You need to configure the function generator at least once after the device has been powered. The first step is to select the type of function generator, causing further steps to depend on your selection. There are two types available: **XY** and **arbitrary**. The XY function generator is only a memory for a table with 4096 values which represent 0-125% of the rated voltage or current of the device, while the arbitrary generator is used for other functions like sine wave, square wave etc.

2) Configure the function generator (part 1)

As a second step, the arbitrary generator requires to first select to which DC input/output value the function is assigned, voltage (U) or current (I). After that you define the number of sequences to run. This does not happen automatically when filling a certain number of sequences with data.

If you are going to use the XY generator, the next step would be to select what sort of XY curve it shall run. Depending on that selection, values you will write to the table memory are interpreted and checked for plausibility.

3) Configure the function generator (part 2)

The last step is to fill the function generator with data. With the arbitrary generator this is done by setting up X out of 99 possible sequences. The number of effective sequences to run is variable, but at least 1.

The XY generator is filled with 1-4096 values.



XY data and sequence data require to be submitted by a dedicated command which requires to wait some time before proceeding. We recommend to wait at least 2 seconds after submitting the data and before the next command.

4) Use the function generator

After this, the function generator is completely configured and can be started.



Switching to a different function generator mode requires to first leave the function generator by sending `[SOURce:]FUNCTION:GENerator:SElect OFF`. Only after the device will allow to select another mode. Previously loaded table or sequence data will be erased when leaving function generator mode.

5.4.12.1 Function overview

The function generator's scope of functions is not the same with all series featuring a function generator. This is an overview which series support which functionality:

	ELR9	PSI9	DT	PSIT	PSB
Arbitrary generator	✓	✓	✓	✓	✓
XY generator	✓	✓	—	—	✓

ModBus & SCPI

5.4.12.2 XY generator: Mode selection (except for series PSB 9000 and PSB 10000)

Command	Description
[SOURce:]FUNctioN:GENerator:SElect_{UI IU PV NONE} [SOURce:]FUNctioN:GENerator:SElect?	Selects the run mode of XY function generator: UI = UI curve and FC curve IU = IU curve PV = Standard PV curve (for the extended EN 50530 PV curve commands refer to section 5.4.17) NONE = Exit function generator

5.4.12.3 XY generator: Mode selection (only series PSB 9000 and PSB 10000)

XY generator configuration of a PSB 9000 series device is slightly different, as there is only an **IU** based table available and the user also has to select for which operation mode the curve is used, means source (PS) or sink (EL) mode. Also, the **FC** function (fuel cell), which only runs in source mode, has to be explicitly selected.

Furthermore, a PSB has memory for two **simple PV** curve, named **PVA** and **PVB**.

Command	Description
[SOURce:]FUNctioN:GENerator:SElect_{FC IUPS IUEL PVA PVB NONE} [SOURce:]FUNctioN:GENerator:SElect?	Selects the run mode of XY function generator: FC = FC curve in source mode IUPS = IU curve in source mode IUEL = IU curve in sink mode IU = IU curve in combined source-sink mode (the current set value from the curve is either set for source or sink mode, depending on the relation between voltage set value and actual voltage on the DC terminal) PVA = Simple PV curve A PVB = Simple PV curve B (for the extended EN 50530 PV curve commands refer to section 5.4.17) NONE = Exit function generator

5.4.12.4 XY generator: Load table data

The XY generator is based on a table with up to 4096 values. Also refer to the operating manual of your device for further details about the XY function generator.

Before actually going to fill the table with data it's required to select what kind of table is going to run, so the device can interpret and check for plausibility as soon as table data is received.

Command	Description
[SOURce:]FUNctioN:GENerator:XY:LEVel_{0...4095}	1. Select one out of 4096 table entries for writing or returns the currently selected entry number.
[SOURce:]FUNctioN:GENerator:XY:DATA_{NRf}> [SOURce:]FUNctioN:GENerator:XY:DATA?	2. Writes a value, for example a voltage value, to the previously with :LEVel selected table entry or returns the value.
[SOURce:]FUNctioN:GENerator:XY:SUBmit	3. Submit the data which has been written so far. Can be any number out of the max. 4096 entries. The rest would then be 0. After this the function can be started
[SOURce:]FUNctioN:GENerator:XY:SECond:LEVel_{0...4095}	PSB 9000 and PSB 10000 series only. Ditto for 2 nd XY table
[SOURce:]FUNctioN:GENerator:XY:SECond:DATA_{NRf}> [SOURce:]FUNctioN:GENerator:XY:SECond:DATA?	
[SOURce:]FUNctioN:GENerator:XY:SECond:SUBmit	

5.4.12.5 Arbitrary generator: Mode selection and configuration

Command	Description
[SOURce:]FUNction:GENerator:SElect_{VOLTAGE CURRENT UI IU PV NONE} [SOURce:]FUNction:GENerator:SElect?	Select the type of function generator: VOLTage = Arbitrary generator for U CURRent = Arbitrary generator for I NONE = Exit function generator
[SOURce:]FUNction:GENerator:WAVE:StArt_{1..99} [SOURce:]FUNction:GENerator:WAVE:StArt?	Defines the start, i.e. first sequence (1...99) or queries the last setting. If only one sequence is used, then it must be :StArt = :ENd . Sequences going to be used should also be written with data before submitting them.
[SOURce:]FUNction:GENerator:WAVE:ENd_{1..99} [SOURce:]FUNction:GENerator:WAVE:ENd?	Defines the end, i.e. last sequence (1...99) or queries the last setting. If only one sequence is used, then it must be :StArt = :ENd .
[SOURce:]FUNction:GENerator:WAVE:NUMber_{0..999} [SOURce:]FUNction:GENerator:WAVE:NUMber?	Defines, how often the sequence block from :StArt to :ENd is cycled through, or queries the last setting. 0 = infinite cycles 1...999 = number of cycles

5.4.12.6 Arbitrary generator: Load sequence data

Sequence data should only be sent to the device after it was switched to function generator mode, which also sets the assignment of the arbitrary generator to U or I.

A function can consist of 1 to 99 sequences, so one sequence is either a complete function or just a part of it. When started, the function generator will execute the sequences from start sequence to end sequence, as defined by the user. With every sequence being variable, the resulting function can be quite complex. The sequence data is loaded into the device with three commands and in a specific order like this:

Command	Description
[SOURce:]FUNction:GENerator:WAVE:LEVel_{1..99} [SOURce:]FUNction:GENerator:WAVE:LEVel?	1. Selects a sequence (similar to HMI access) to write or queries the currently selected sequence number
[SOURce:]FUNction:GENerator:WAVE:INdEx_{0...7} [SOURce:]FUNction:GENerator:WAVE:INdEx?	2. For the selected sequence, a set of parameters can be configured. This command selects the parameter between 0 and 7 with value INdEx . The next command (:DATA), is then used to write a value. The indexes are explained below. Can also be used to query the current index.
[SOURce:]FUNction:GENerator:WAVE:DATA_{<NRf> [SOURce:]FUNction:GENerator:WAVE:DATA?	3. This will write a value, for example a frequency, to the previously selected parameter, as part of the sequence. Can also be used to query the last value.
[SOURce:]FUNction:GENerator:WAVE:SUBmit	4. Submits all data. Without sending this command, the FG can be started, but will run with all values being zero



The AC and DC start and end values have a dependency from each other. Rule of thumb: use of the AC part requires to set DC values first, else the AC values are not accepted by the device and an error is put into the SCPI error buffer. The DC values (start, end) must not be smaller than the related AC values (start, end).

It can be useful to read back a value that was just written to the device, in order to verify whether it has been accepted or not. Alternatively, you may read the error queue.

When adjusting parameters for the arbitrary function generator manually on the device's control panel, they are limited to each so the resulting signal will work as expected. But here, in remote control, there will be no plausibility check and so it's up to the user to write correct values.

For example, index 0 is connected to index 5, as the DC value is the base line of the AC amplitude. It means, if you, for instance, want to achieve a sine wave with 5 A amplitude on the DC input current of an electronic load, the base line of the resulting sine wave has to be at minimum 5 A, else the negative wave will be clipped at 0. Indexes 5 and 6 are adjustable DC offsets which move the AC wave's base line on the Y axis. So the values in indexes 5 and 6 should at least be as high as index 0 or 1 (whichever is bigger), but they can also be higher. See figures below.

ModBus & SCPI

In relation to the adjustments for a function as they can be done on the device's front panel, following indexes are selectable and readable/writable with sub command **:DATA**.

Index	Parameter	Data type	Unit	Value range	Note
0	Start value (amplitude)	Float	A, V	0...Nominal value (U or I)	For AC part only
1	End value (amplitude)	Float	A, V	0...Nominal value (U or I)	For AC part only
2	Start frequency in Hz	Integer	Hz	0...10000	For AC part only
3	End frequency in Hz	Integer	Hz	0...10000	For AC part only
4	Start angle in °	Integer	-	0...359	For AC part only
5	Start level (offset)	Float	A, V	0...Nominal value (U or I) PSB series only: -Nom. value (U or I)...+ Nom. value (U or I)	For AC and DC part
6	End level (offset)	Float	A, V	0...Nominal value (U or I) PSB series only: -Nom. value (U or I)...+ Nom. value (U or I)	For AC and DC part
7	Sequence time	Float	s	0.0001...36000	



In case start and end value (indexes 0+1 and indexes 5+6) are not equal, the device expects a certain minimum change of $\pm 0.058\%/s$ resp. of ± 9.3 Hz/s for the start and end frequency (indexes 2+3) over the sequence time. It's thus, for example, not possible to let the input current rise by 1 A over 1 h (ramp), because this exceeds the internal set value resolution by far. Another example: with the sequence time being set to 2 s, a start frequency of 1 Hz and end frequency of 10 Hz would not be accepted, because difference only 9 Hz/s, but start frequency of 30 Hz and end frequency of 5 Hz would.

Parameter assignment illustrated by an example curve:

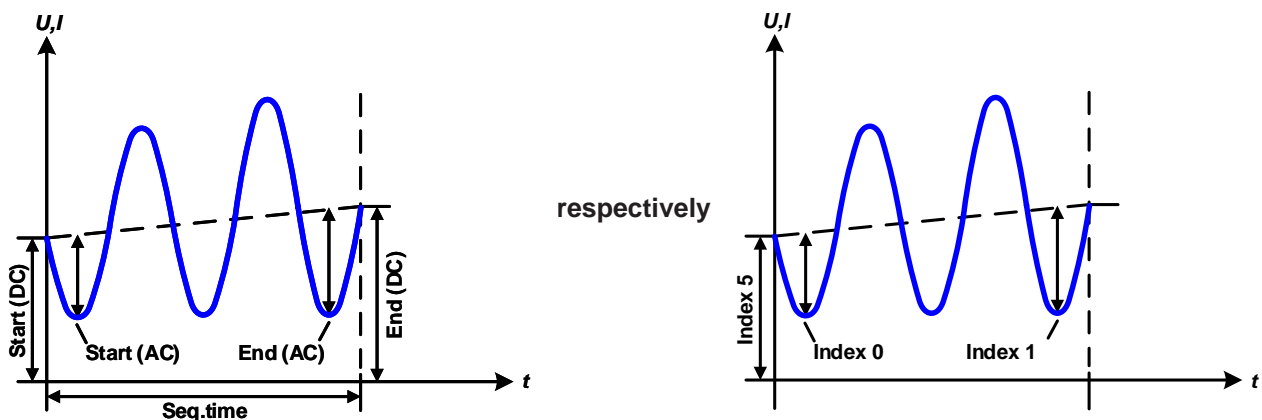

5.4.12.7 XY generator: Control

After the configuration of the XY generator and after all necessary table data has been loaded it can be started by simply switching the DC output/input of the device on. This is the actual function run and is only stops due to device alarms or abortion by the user.

5.4.12.8 Arbitrary generator: Control

Contrary to the XY generator where the curve is immediately active when switching on the DC output/input, the arbitrary generator requires run control by command. The run cannot be paused. It means, once the function is stopped, no matter by what reason, the next start will run from the beginning, the first sequence in use.

Command	Description
[SOURCE:]FUNCTION:GENERator:WAVE:STATE_{RUN STOP}	Starts/stops the arbitrary function generator or queries the STATE
[SOURCE:]FUNCTION:GENERator:WAVE:STATE?	

ModBus & SCPI

5.4.12.9 Special function "Simple PV" (photovoltaics)

ELR9	ELR5	PS9	PSI9	PSI5	PSE	DT	PST	PSIT	EL3	PSB	PSBE	PS3
-	-	-	✓	-	-	-	-	-	-	✓	-	-



For the extended PV function EN 50530 refer to section „5.4.17. Commands for the extended PV simulation“.

The photovoltaics function (PV), as available in certain power supply series, is based on the XY function generator. In remote control it's required to load a complete, precalculated table with 4096 values into the device, contrary to the more comfortable way on the HMI where you set up 4 simulation related parameters by entering values and the device would then calculate and load the table. But the HMI method can be used to save the calculated table data for use in remote control. In order to get the table data calculated you have two options:

1. It's done using external tools and saved as, for example, CSV file which also allows for loading it later from USB stick or it's calculated in a custom software and directly transferred to the device.
2. You use the HMI, enter four PV simulation related parameters, let the device calculate and load the table, then go back in the menu to find an option to save the table data to USB stick.

During function run, the irradiation value which simulates different light situations, can be adjusted. The irradiation impacts the short-circuit current (I_{sc}) as a factor.

Command	Description
[SOURCE:]IRRadiation_<NR1> [SOURCE:]IRRadiation?	Adjust or queries the irradiation value during the solar panel simulation in a range of {0...100} per cent, which affects the DC current and shifts the MPP on the Y axis

Given that the device is already in remote control and the XY table for the PV function is already calculated and ready to be loaded, following procedure is intended:

► How to setup the device for the simple PV function

No.	Command	Description
1	FUNC:GEN:SEL_PV	Not for PSB 9000 and PSB 10000 series models: Select the PV function for the XY generator. By sending this command the device will switch to function generator mode
	FUNC:GEN:SEL_PVA or FUNC:GEN:SEL_PVB	For PSB 9000 and PSB 10000 models: These devices have two memory space for PV. You can use any of them. Switching between both is possible, before or even after loading table data, but only whilst the DC terminal is switched off.
2	FUNC:GEN:XY:LEVEL_0	Subsequently write all XY table values for the PV curve into the device
3	FUNC:GEN:XY:DATA_150	
...		
8192	FUNC:GEN:XY:LEVEL_4095	
8193	FUNC:GEN:XY:DATA 0	
8194	FUNC:GEN:XY:SUB	Submit the written data

After submitting all data, it's necessary to wait some time (~1 s) before starting the simulation. Optionally and if not already done, set additional global limits like voltage and power, either to maximum or any other value that does not interfere the simulation. The voltage here should be set to the open circuit voltage (U_{oc}), alternatively to maximum:

No.	Command	Description
8195	VOLT_MAX	Set voltage to max, independent from the model
8196	POW_MAX	Set power to max, independent from the model

After all is set, you can run the function and control the simulation and irradiation. The irradiation then acts as a factor that is multiplied to the current value that is read from the table, so changing this value moves the power point vertically on the Y axis. For an illustration of the PV curve, refer to your PSI 9000 series device manual.

► How to control the device during the PV function run

No.	Command	Description
8197	OUTP_ON	Switch the DC output of your device on to make the function start
8198	IRR_85	Set irradiation to 85% (example) or any other value between 0 and 100
8199	OUTP_OFF	Switch the DC output of your device off to make the function stop
8200	FUNC:GEN:SEL_NONE	Parameter NONE selects no function generator type and leaves the function generator mode

5.4.12.10 Special function: FC (fuel cell)

ELR9	EL9	PS9	PSI9	PSI5	PSE	DT	PST	PSIT	EL3	PSB	PSBE	PS3
-	-	-	✓	-	-	-	-	-	-	✓	-	-

The fuel cell function (FC) is based on the XY function generator, as available in certain power supply series. In remote control it's only possible to load a complete, precalculated table with 4096 values into the device. Basically, an FC curve is an UI curve, so that with a PSI 9000 device you would select mode "UI" for the XY generator. For a PSB 9000 or PSB 10000 device, which doesn't support UI curves, it requires different settings and data. Overview:

	PSI 9000 / PSI 10000	PSB 9000 / PSB 10000
XY generatormodus	UI	FC
Curve type	UI	IU
Table contains	Voltage values	Current values

Loading table is in the contrary to the more comfortable way on the HMI where you define 4 points on the curve by entering values and the device would then calculate and load the table. But the HMI method can be used to save the calculated table data for use in remote control.

In order to the table data calculated you have two options:

1. You do it with external tools, such as MS Excel, and then load all data into the device.
2. You use the HMI, enter the four points, let the device calculate and load the table, then leave FG mode and back in the menu there is an option to save the table data to USB stick.



The 2nd method is recommend for use with PSB 9000 / PSB 10000 series devices, as there is no official formula available to translate an FC-UI table into current values (IU table).

5.4.13 Commands for remote control of the sequence generator

ELR9	ELR5	PS9	PSI9	PSI5	PSE	DT	PST	PSIT	EL3	PSB	PSBE	PS3
–	✓	–	–	–	–	–	–	–	–	–	–	–



Sequence data written with SCPI commands is permanently stored inside the device and is also connected to the sequence data which you can edit on the front panel (HMI).

The sequence generator of the ELR/ELM 5000 series is a simplified version of the arbitrary function generator of other series, but the handling is almost identical.

When operating the sequence generator on the control panel of the device, it enforces a certain procedure of setup before getting to the actual starting point. The single commands can not enforce that procedure, so it's up to the user to use them in the correct sequence. What to do:

- 1) Configure the sequence generator. There are two items. One is to load the data for the sequence points, at least if different settings than stored are going to be used. The other settings, like start sequence point etc., are recommended to always be configured.
- 2) Run and control the sequence generator.

5.4.13.1 Configuration of the sequence generator

Command	Description
[SOURce:]FUNCTION:GENERator:WAVE:START_{1..100} [SOURce:]FUNCTION:GENERator:WAVE:START?	Defines the sequence point (1...100) to start from or queries the last setting. If only one sequence point is used, then it must be :START = :END. Sequence points going to be used should also be written with data before using them.
[SOURce:]FUNCTION:GENERator:WAVE:END_{1..100} [SOURce:]FUNCTION:GENERator:WAVE:END?	Defines the sequence point (1...100) to stop at or queries the last setting. If only one sequence point is used, then it must be :START = :END.
[SOURce:]FUNCTION:GENERator:WAVE:NUMBER_{0..999} [SOURce:]FUNCTION:GENERator:WAVE:NUMBER?	Defines, how often the sequence block from :START to :END is cycled through or queries the last setting. 0 = infinite cycles 1...999 = number of cycles

5.4.13.2 Control the arbitrary function generator

Command	Description
[SOURce:]FUNCTION:GENERator:WAVE:STATE_{RUN STOP} [SOURce:]FUNCTION:GENERator:WAVE:STATE?	Starts/stops the sequence generator or queries the state. With the start of the generator in remote control, the display of the device will automatically switch to sequence generator mode.

5.4.13.3 Load sequence point data

Sequence data should can always be sent to the device while the DC input is switched off. There is no special mode to activate before.

Which ones of the 100 sequence points are going to be filled with data is determined by the user, as well as the points to start from and to stop at and the number of cycles of the entire sequence. The block of sequence points can be of arbitrary size. When processing a sequence point during the sequence run which has not been filled with data, it would result in an interrupt of the minimum sequence point time of 300 ms, along with values U and I being zero for that moment.

Commands to load sequence point data:

Command	Description
[SOURce:]FUNCTION:GENERator:WAVE:LEVEL_{1...100} [SOURce:]FUNCTION:GENERator:WAVE:LEVEL?	Selects a sequence point (similar to HMI access) for write actions or queries the number of the currently selected sequence point

ModBus & SCPI

Command	Description
[SOURce:]FUNCtion:GENErator:WAVE:INDex_{0...3} [SOURce:]FUNCtion:GENErator:WAVE:INDex?	For the selected sequence point, a set of 4 parameters has to be configured. This command selects the parameter between 0 and 3 with :INDEX . The next command (:DATA) is then used to write a value. The indexes are explained below. Can also be used to query the current index.
[SOURce:]FUNCtion:GENErator:WAVE:DATA_<NRf> [SOURce:]FUNCtion:GENErator:WAVE:DATA?	This will write a value to the previously selected parameter, as part of the sequence point definition. Can also be used to query the last value.
[SOURce:]FUNCtion:GENErator:WAVE:SUBmit	Submits all data. Without sending this command, the sequence generator would use formerly stored data.

These commands would be repeated for every sequence point to load. When using the full set of 100 sequence points it would require to send 900 commands, see steps 1-9 in the example below.

In relation to the adjustments for a function as they can be done on the device's front panel, following parameters are selectable with **:INDEX** and readable/writable with **:DATA**.

Index	Parameter	Value range
0	Sequence point voltage set value in Volt	0...Nominal value of U
1	Sequence point current set value in Ampere	0...Nominal value of I
2	Sequence point power set value in Watt	0...Nominal value of P
3	Sequence point time in seconds	0.300...36000.000 (i. e. 300 ms ... 10 h), step width 1 ms



In case any of the three set values is not written, it keeps the last stored value. It's recommended to always set all three value to ensure the result of the sequence is as expected.



The adjustment limits on the HMI ("Limits") do no apply here.

5.4.13.4 Example command sequence

Assumption: the source shall be loaded with 20 A for 60 seconds. Because the ELM 5000 load module can only take up to 320 W of power, the input voltage must not reach 16 V for this run, else the power would be limited by decreasing the input current below the programmed value. The power is set to maximum.

No.	Command	Description
1	FUNC:GEN:WAVE:LEV_12	Selects the 12th sequence point for writing values, for this example only this particular point is going to be written and used for the sequence run
2	FUNC:GEN:WAVE:IND_0	Select index 0: Voltage set value.
3	FUNC:GEN:WAVE:DATA_0	Set voltage for sequence point 12 to 0 V. Could be 0...80 for an 80 V model. With an electronic load, the voltage is secondary and when running it in CC mode is intended, the voltage would usually be set to 0
4	FUNC:GEN:WAVE:IND_1	Select index 1: Current set value
5	FUNC:GEN:WAVE:DATA_20	Set current for the sequence point 12 to 20 A. Could be 0...25 for an 80 V model.
6	FUNC:GEN:WAVE:IND_2	Select index 2: Power set value
7	FUNC:GEN:WAVE:DATA_320	Set power of sequence point 12 to 320 W. If the total power shall not be limited to less than nominal for the entire sequence, it's required to set every sequence point's power to maximum, because there is no global power value for the sequence.
8	FUNC:GEN:WAVE:IND_3	Select index 3: Time
9	FUNC:GEN:WAVE:DATA_60	Sets the time to elapse while the set values of sequence point 12 are effective to 60 s or 1 minute.
10	FUNC:GEN:WAVE:SUBMIT	Submit all sequence data
11	FUNC:GEN:WAVE:START_12	Sets the first sequence point of the sequence to 12
12	FUNC:GEN:WAVE:END_12	Sets the last sequence point of the sequence also to 12
13	FUNC:GEN:WAVE:NUM_1	Sets 1 cycle, i. e. no repetition

ModBus & SCPI

Result of this setup: when running the sequence generator, no matter if the DC input is already switched on or not, the electronic load will set the values of sequence point 12 (0 V, 20 A, 320 W) and switch on the DC input. The load will then take 20 A for a period of 60 seconds. After the 60 seconds have elapsed, the sequence generator would automatically stop after 1 cycle. With the DC input remaining on after the sequence stop, the load would continue to draw 20 A. This could be unwanted.

In order for the current to be zero after the end of the sequence run, another sequence point could be configured. The chain of commands, as shown above, would change after step 9 like this:

No.	Command	Description
10	FUNC:GEN:WAVE:LEV_13	Selects the 13th sequence point for writing values
11	FUNC:GEN:WAVE:IND_1	Select index 1: Current set value
12	FUNC:GEN:WAVE:DATA_0	Set current for the sequence point 13 to 0 A.
13	FUNC:GEN:WAVE:SUBMIT	Submit all sequence data
14	FUNC:GEN:WAVE:START_12	Sets the first sequence point of the sequence to 12
15	FUNC:GEN:WAVE:END_13	Sets the last sequence point of the sequence to now 13
16	FUNC:GEN:WAVE:NUM_1	Sets 1 cycle, i. e. no repetition

The voltage value and time of sequence point 13 don't matter. The sequence generator would then stop after point 13 with 0 A and DC input switched on. Since no current is flowing, it could be considered as "input off".

5.4.14 Commands for remote control of the MPP tracking feature

ELR9	ELR5	PS9	PSI9	PSI5	PSE	DT	PST	PSIT	EL3	PSB	PSBE	PS3
✓	✓	–	–	–	–	✓(1)	–	–	✓	✓	–	–

(1 Not with PSI 9000 DT)

Maximum Power Point (MPP) tracking is something inverters for solar panels use. The MPP tracking emulates the tracking behaviour of such inverters. The feature itself and its modes and settings are described in the device manual. Here only the corresponding commands for remote setup and control are explained.

5.4.14.1 Configuration of the MPP tracking

The configuration is done with 14 indexes and specific :DATA commands:

Command	Description
[SOURCE:]FUNCTION:GENERATOR:MPP:INDEX_0 [SOURCE:]FUNCTION:GENERATOR:MPP:DATA[?]<NRf> {NONE MPP1 MPP2 MPP3 MPP4}	Index 0: MPP tracking mode selection MPP1: MPP tracking mode 1 (Find MPP) MPP2: MPP tracking mode 2 (Track) MPP3: MPP tracking mode 3 (Fast track) MPP4: MPP tracking mode 4 (User curve) NONE: Deactivate MPPT
[SOURCE:]FUNCTION:GENERATOR:MPP:INDEX_1 [SOURCE:]FUNCTION:GENERATOR:MPP:DATA[?]<NRf>	Index 1: Set the open circuit voltage Uoc (0-Unom)
[SOURCE:]FUNCTION:GENERATOR:MPP:INDEX_2 [SOURCE:]FUNCTION:GENERATOR:MPP:DATA[?]<NRf>	Index 2: Set the short-circuit current Isc (0-Inom)
[SOURCE:]FUNCTION:GENERATOR:MPP:INDEX_3 [SOURCE:]FUNCTION:GENERATOR:MPP:DATA[?]<NRf>	Index 3: Set the voltage limit for fast track mode 3 Umpp (0-Unom)
[SOURCE:]FUNCTION:GENERATOR:MPP:INDEX_5 [SOURCE:]FUNCTION:GENERATOR:MPP:DATA[?]<NRf>	Index 5: Set the MPP for fast track mode 3 Pmpp (0-Pnom)
[SOURCE:]FUNCTION:GENERATOR:MPP:INDEX_6 [SOURCE:]FUNCTION:GENERATOR:MPP:DATA[?]<NRf>	Index 6: Set ΔP (in Watts), a difference to the MPP above which the tracker starts to find the MPP again (only used with mode 2 and mode 3) The allowed range is defined as 0-50W for some series, for others it's 0-Pnom.
[SOURCE:]FUNCTION:GENERATOR:MPP:INDEX_7 [SOURCE:]FUNCTION:GENERATOR:MPP:DATA?	Index 7: resulting MPP Reads three values (Uact, Iact, Pact) which define the MPP (modes 1, 2 and 4)

ModBus & SCPI

Command	Description
[SOURCE:]FUNCTION:GENERATOR:MPP:INDEX_8 [SOURCE:]FUNCTION:GENERATOR:MPP:LEVEL[?]{1-100} [SOURCE:]FUNCTION:GENERATOR:MPP:DATA[?]<Nrf>	Index 8: Set voltage values for mode 4 1-100: Select the value to set Set value (0-Unom)
[SOURCE:]FUNCTION:GENERATOR:MPP:INDEX_9 [SOURCE:]FUNCTION:GENERATOR:MPP:LEVEL[?]{1-100} [SOURCE:]FUNCTION:GENERATOR:MPP:DATA?	Index 9: Measured results of mode 4 Select measured data to read Read data (three values: Uact, Iact, Pact)
[SOURCE:]FUNCTION:GENERATOR:MPP:INDEX_10 [SOURCE:]FUNCTION:GENERATOR:MPP:DATA[?]{5-60000}	Index 10: Regulation interval for mode 4 stepping or for next tracking action in the other mode (this parameter is only available in remote control; for manual control it's set to minimum) Interval in milliseconds
[SOURCE:]FUNCTION:GENERATOR:MPP:INDEX_11 [SOURCE:]FUNCTION:GENERATOR:MPP:DATA[?]{1-100}	Index 11: Start number for mode 4 of the voltage values set with index 8 Set start number
[SOURCE:]FUNCTION:GENERATOR:MPP:INDEX_12 [SOURCE:]FUNCTION:GENERATOR:MPP:DATA[?]{1-100}	Index 12: End number for mode 4 of the voltage values set with index 8 Set end number
[SOURCE:]FUNCTION:GENERATOR:MPP:INDEX_13 [SOURCE:]FUNCTION:GENERATOR:MPP:DATA[?]{0-65535}	Index 13: Number of repetitions for mode 4 Repetitions of the scan

5.4.14.2 Control of the MPP tracking

The MPP tracking is started or stopped with a separate command. Independent from the DC input condition of the device it would automatically switch the DC input on when sending RUN.

Command	Description
[SOURCE:]FUNCTION:GENERATOR:MPP:STATE[?]{RUN STOP}	RUN = Runs the MPP tracking in the configured mode STOP = Stops MPP tracking anytime, nom matter if there is a positive result or not ? = Read the tracking status

The tracking status, as it can be read with command FUNC:GEN:MPP:STAT?, returns the current status as RUN (running) or STOP (stopped). The meaning of STOP slightly differs, depending on the chosen mode:

Mode 1: STOP means, the MPP has been found (positive result) and the tracking has been finished

Modes 2 and 3: These modes don't stop automatically, so STOP only returns the status as set by :STAT command

Mode 4: STOP means, the user curve has been processed the defined number of cycles

5.4.15 Commands for alarm management

In remote control operation it's also important to manage alarms correctly. This can be done the same way as in manual control. When using SCPI command language, device alarms are indicated via status register which can be polled. Furthermore, most alarms have to be acknowledged.

5.4.15.1 Reading device alarms

Reading device alarms should happen in certain intervals, by querying the Questionable status register by either the subregister CONDITION or EVENT. The command STAT:QUES:COND? or STAT:QUES? resp. STAT:QUES:EVENT? return a value that represents certain bits (see „5.4.2 Status registers“ on page 39), indicating various statuses. When a bit is set, it means a certain alarm is present. Refer to the device's operating manual for details about device alarms.

5.4.15.2 Acknowledging device alarms

In order to make the user take notice of device alarms, they have to be acknowledged after they occurred and vanished again. This will delete those alarms from the status register and should be only be done after they have been recorded. To delete/acknowledge an alarm, the command SYST:ERR? resp. SYST:ERR:ALL? is used, which also serves to query other errors.

In case one or multiple alarms are still present, they won't be cleared from the register.

There is one exception in handling, the OT (overtemperature) error. This doesn't require extra acknowledgement and thus won't be indicated anymore in CONDITION once it's gone.

5.4.15.3 Alarm counters

These counters count alarm occurrences since the last time the device was powered. They can be read by command anytime, are not stored when the device is switched off and are purged by reading.

Command	Description
SYSTem:ALARm:COUNT:OVOLtage?	Counts overvoltage alarms (OVP, adjustable threshold)
SYSTem:ALARm:COUNT:OTEMperature?	Counts overtemperature alarms (OT, not adjustable)
SYSTem:ALARm:COUNT:OPOWer?	Counts overpower alarms (OPP, adjustable threshold)
SYSTem:ALARm:COUNT:OCURrent?	Counts overcurrent alarms (OCP, adjustable threshold)
SYSTem:ALARm:COUNT:PFail?	Counts power fail alarms (PF, not adjustable)
SYSTem:ALARm:COUNT:SHARebusfail?	Only with series PSB 10000, PSI 10000 and ELR 10000. Count Share bus fail alarms (SF, not adjustable)
SYSTem:ALARm:COUNT:FLOatovp?	Only with series PSB 10000, PSI 10000 and ELR 10000. Count Floating OVP alarms (FOVP, not adjustable)

5.4.15.4 Example

You are running the device in remote control and poll the alarm status with STAT:QUES:COND? command in a certain interval and you always receive value 3072. This is the sum of the bit values of bits 10 (remote) and 11 (output/input on). It tells you that remote control is active and the DC output/input is switched on. Then a device alarm occurs caused by the unit overheating. When reading the questionable register the next time, bit 3 should indicate the OT alarm for you to take notice. Additionally, the DC output/input might be indicated as switched off, besides the shut down power stages, which does not happen with every device series. Thus the returned value could be 1032 or 3080. Both contain bit's 3 value of 8.

ModBus & SCPI

5.4.16 Commands for presets (Recall)

ELR9	ELR5	PS9	PSI9	PSI5	PSE	DT	PST	PSIT	EL3	PSB	PSBE	PS3
–	–	–	–	✓	–	–	–	–	–	–	–	–

The Recall feature, as integrated with power supply series PSI 5000 A, can also be configured and used remotely. Here, standard SCPI commands are used and thus it's a little different compared to ModBus. Overview of commands used only for access to the presets:

Command	Description
*RCL_{1...9}	Recalls, i.e. loads one out of nine presets from the internal storage. The preset consists of four values (voltage, current, OVP, OCP) and overwrites the currently active values on the DC output. The command can only be executed while the DC output is switched off.
*SAV_{1...9}	Save the four currently active values (set value of voltage, set value of current, values of OVP and OCP) on the DC output to the selected preset for future use, when they are recalled using the *RCL {1...9}. The command can only be executed while the DC output is switched off.
MEMory:STATe:DELeTe_{1...9}	Deletes the selected preset by writing zero to all values. The preset can later be written with custom values anytime.
MEMory:STATe:VALid?_{1...9}	Triggers a memory check to determine if a previously written preset has been written correctly to the internal storage and the values are OK and valid. Will return a 1 of all is OK and a 0, if not OK.

Similar to manually operating the recall feature on the control panel of the device, these commands are only accepted while the DC output is switched off.

In order to set the four value that can be stored as a preset, common commands like [SOURce:]VOLTage are used. Also see examples below.

5.4.16.1 Example sequence for setting up and saving a preset

For example, you have a power supply PSI 5040-20 A with 49 V nominal voltage and 20 A nominal current. Now you want to set up and save preset number 5 for later recall. Let's say the value to set up are $U = 10\text{ V}$, $I = 5\text{ A}$ and overvoltage protection (OVP) = 12 V. The protection is used to prevent the load from high voltage overshoots which can result from a typical regulation characteristics when setting the current to zero while voltage is put out and then releasing the current again, so the voltage "jumps".

The overcurrent protection is of now priority for you, but it's recommended to set it as well, so it won't interfere. There is always a setting which you might not know, so let's set it to maximum (here: 22 A). With all being prepared, following sequence of commands would have to be sent to the device:

Nr.	Command	Description
1	OUTP_OFF	Switch the DC output off first (no matter if already off), because saving the preset requires the output to be off and changing the output values with the output being on and with load attached could result in unwanted behaviour.
2	VOLT_10	Set 10 V output voltage (normal set value)
3	CURR_5	Set 5 A output current (normal set value)
4	VOLT:PROT_12	Set OVP threshold to 12 V
5	CURR:PROT_22	Set OCP threshold to 22 A
6	*SAV_5	Store preset 5
7	MEM:STAT:VAL?_5	(optional) Query, if preset 5 has been stored correctly and values are valid

5.4.16.2 Example sequence for recalling a preset

During remote control, the four values that are stored in a preset could also be set with four small commands, so that recalling a preset in remote control is something that will be used quite rarely. The big advantage of setting the values directly is that it doesn't matter whether the DC output is switched on or off, they can be sent anytime.

ModBus & SCPI

In case you still want to recall a preset, for example number 3, make following steps:

Nr.	Command	Description
1	OUTP_OFF	Switch the DC output off first (optional, if already off), so the preset can be recalled
2	*RCL 3	This will recall preset 3 and overwrite the former output values U, I, OVP and OCP with the ones stored in the preset
3	OUTP_ON	(optional) Switch DC output on again

In order to also read what values are stored in a preset, you would have to recall first and anyway, but then you could query the four output values directly to know what a specific preset has stored:

Nr.	Command	Description
1	VOLT?	Queries the output voltage set value, as previously recalled from a preset
2	CURR?	Queries the output current set value, as previously recalled from a preset
3	VOLT:PROT?	Queries the OVP threshold value, as previously recalled from a preset
4	CURR:PROT?	Queries the OCP threshold value, as previously recalled from a preset

ModBus & SCPI

5.4.17 Commands for the extended PV simulation

ELR9	ELR5	PS9	PSI9	PSI5	PS5	PSE	DT	PST	PSIT	EL3	PSB	PSBE	PS3
–	–	–	✓	–	–	–	–	–	–	–	✓	–	–

Photovoltaics simulation is a function based on the XY generator and is only featured with some power supply series. With date 04/2019 these are:

- PSI 9000 2U - 24U
- PSI 9000 WR 3U
- PSB 9000 / PSB 10000

The extended solar module simulation according to **DIN EN 50530** is supported since KE firmware version KE 2.19/HMI 2.11 (PSI) resp KE 2.25/HMI 2.04 (PSB 9000). It means, this function can be retrofitted to the supported series by installing an update.

All simulation related parameters, as settable with the below listed commands, are specified and described in the norm. Thus the norm paper is considered as additional reference to further information.

5.4.17.1 General configuration

Command	Description
FUNCTION:PHOTovoltaics:MODE_{OFF ET UI DAYET DAYUI} FUNCTION:PHOTovoltaics:MODE?	General mode selection for the PV simulation OFF = simulation mode off (default) ET = Continuous mode, temperature and irradiation can be varied during simulation UI = Continuous mode, voltage and current of the MPP can be varied during simulation DAYET = Day trend mode, no values can be varied, the data set consists of an index, a temperature value, an irradiation value and a dwell time DAYUI = Day trend mode, no values can be varied, the data set consists of an index, MPP voltage and current values and a dwell time
FUNCTION:PHOTovoltaics:IMODE_{MPP ULIK} FUNCTION:PHOTovoltaics:IMODE?	Input mode (applies to all modes selectable with :MODE command, also see matrix and examples in 5.5.3) MPP = The base values to calculate the PV curve from are entered as U_{mpp} and I_{mpp} . These values are adjustable simulation mode UI (default) ULIK = The base values to calculate the PV curve from are entered as U_{oc} (open circuit voltage) and I_{sc} (short-circuit current). These values are adjustable in simulation mode ET

5.4.17.2 Day trend mode configuration

The below listed commands can only be used if any of the day trend modes **DAYET** or **DAYUI** (see above) has been set before and will else return an error.



It's recommended to clear the old day data with :DAY CLEAR command before loading a new set, especially if the new set is shorter.

Commands	Description
FUNCTION:PHOTovoltaics:DAY:INTERpolate_{ON OFF} FUNCTION:PHOTovoltaics:DAY:INTERpolate?	Only for modes DAYET and DAYUI : ON = Interpolation on OFF = Interpolation off (default)
FUNCTION:PHOTovoltaics:DAY:MODE_{READ WRITE} FUNCTION:PHOTovoltaics:DAY:MODE?	Only for modes DAYET and DAYUI : Day trend mode data access type READ = Read only (default) WRITE = Write only
FUNCTION:PHOTovoltaics:DAY_{CLEAR}	Only for modes DAYET and DAYUI : Clear all data

ModBus & SCPI

Commands	Description										
FUNCTION:PHOTOvoltaics:DAY:INDEX_{1-100000} FUNCTION:PHOTOvoltaics:DAY:INDEX?	Only for modes DAYET and DAYUI : Select the data index before re-reading day trend data. For writing day trend data, this index values is ignored. Use the index in FUNC:PHOT:DAY:DATA command instead.										
FUNCTION:PHOTOvoltaics:DAY:DATA_{<NR1>, <NRf>, <NRf>, <NR1>} FUNCTION:PHOTOvoltaics:DAY:DATA?	Only for modes DAYET and DAYUI : Write one set of day trend data (4 values) or read them back from it, which requires prior index selection. Depending on the selected day trend mode, different data is returned upon read or must be provided when writing. <table border="1" style="width: 100%; border-collapse: collapse;"> <thead> <tr> <th>Mode DAYET:</th> </tr> </thead> <tbody> <tr> <td>1. value = index, range: 1- 100000</td> </tr> <tr> <td>2. value = irradiation in W/m², range: 0-1500</td> </tr> <tr> <td>3. value = temperature in °C, range: -40...+80</td> </tr> <tr> <td>4. value = Dwell time of index in ms, range: 500...1800000 (^=0,5s...0,5h)</td> </tr> <tr> <th>Mode DAYUI:</th> </tr> <tr> <td>1. value = index, range: 1-100000</td> </tr> <tr> <td>2. value = Umpp in V, range: 0...rated voltage</td> </tr> <tr> <td>3. value = Impp in A, range: 0...rated current</td> </tr> <tr> <td>4. value = Dwell time of index in ms, range: 500...1800000 (^=0,5s...0,5h)</td> </tr> </tbody> </table>	Mode DAYET :	1. value = index, range: 1- 100000	2. value = irradiation in W/m ² , range: 0-1500	3. value = temperature in °C, range: -40...+80	4. value = Dwell time of index in ms, range: 500...1800000 (^=0,5s...0,5h)	Mode DAYUI :	1. value = index, range: 1-100000	2. value = Umpp in V, range: 0...rated voltage	3. value = Impp in A, range: 0...rated current	4. value = Dwell time of index in ms, range: 500...1800000 (^=0,5s...0,5h)
Mode DAYET :											
1. value = index, range: 1- 100000											
2. value = irradiation in W/m ² , range: 0-1500											
3. value = temperature in °C, range: -40...+80											
4. value = Dwell time of index in ms, range: 500...1800000 (^=0,5s...0,5h)											
Mode DAYUI :											
1. value = index, range: 1-100000											
2. value = Umpp in V, range: 0...rated voltage											
3. value = Impp in A, range: 0...rated current											
4. value = Dwell time of index in ms, range: 500...1800000 (^=0,5s...0,5h)											
FUNCTION:PHOTOvoltaics:TECHnology_{MAN CSI THIN} FUNCTION:PHOTOvoltaics:TECHnology?	Panel technology preselection. Determines if some simulation parameters are fixed or accessible MAN = Manual mode (all parameters unlocked) CSI = cSi technology panel (default) THIN = thin film technology panel										

5.4.17.3 Data recording

The device can record data while the PV simulation is running in any mode. It records up to 576,000 data sets with 6 values each (actual values of U, I, P and MPP values U, I, P). The recording can be started with the simulation or while it runs. Once the internal memory is filled, it overwrites from the beginning and the number of recorded data sets (:REC:NUM?) is reset to 0. There is one new data set recorded every 100 ms, so that it covers a total time of exactly 16 hours.

The recording is either stopped at the end of the simulation or on purpose by the user. After the stop, the recorded data can be read set by set. In case they are need to be saved, they should be read as long as the unit is powered, because the internal memory data is not stored.

Command	Description
FUNCTION:PHOTOvoltaics:RECORD:ACTIVE_{ENABLE DISABLE} FUNCTION:PHOTOvoltaics:RECORD:ACTIVE?	Data recording ENABLE = activated DISABLE = deactivated (default)
FUNCTION:PHOTOvoltaics:RECORD_{CLEAR}	Clear recorded data
FUNCTION:PHOTOvoltaics:RECORD:NUMBER?	Number of already recorded data sets (1-576000)
FUNCTION:PHOTOvoltaics:RECORD:INDEX_{1-576000} FUNCTION:PHOTOvoltaics:RECORD:INDEX?	Set or read the index number prior to read a data set with :DATA? command

Command	Description
FUNCtion:PHOTovoltaics:RECOrd:DATA?	<p>Read data set X from the previously selected index. The device will then return following values separated by commas, representing a snapshot from a certain time:</p> <ol style="list-style-type: none"> 1. value = Index number 2. value = Actual voltage on the DC output 3. value = Actual current on the DC output 4. value = Actual power on the DC output 5. value = Umpp (voltage in the MPP) 6. value = Impp (current in the MPP) 7. value = Pmpp (power in the MPP)



After selecting the index with **FUNC:PHOT:REC:IND**, prior to reading the data set, it requires some time (<5 ms) to pass before the device can return the true data of the index from an internal buffer. Being too early with the request command will cause the device to write an error into the error queue. After data reception the correct data can be verified by comparing the index number in the data set with the index you selected with **FUNC:PHOT:REC:IND**.



After simulation start the device will calculate the first PV curve. This takes about 500 ms. But the first data set is already recorded 100 ms after simulation start, so the first 3-4 data set are erroneous. This won't be the case if the recording is started at least 500 ms after the simulation start.

5.4.17.4 Status commands

Status commands and those which read result values from the simulation can be used at any time, but it's recommend to carefully chose the moment and order of use.

Command	Description
FUNCtion:PHOTovoltaics:MPP:VOLTage?	Voltage in the MPP, in V. The MPP results from the PV simulation curve, which is calculated by the given simulation settings. The voltage can be between 0 and the rated device voltage.
FUNCtion:PHOTovoltaics:MPP:CURREnt?	Current in the MPP, in A. Can be between 0 and rated current.
FUNCtion:PHOTovoltaics:MPP:POWER?	Power in the MPP, in A. Can be between 0 and rated power.
FUNCtion:PHOTovoltaics:STATE?	<p>PV simulation status</p> <p>STOP = Simulation has stopped normally, either due to user action or end of day trend</p> <p>RUN = Simulation running</p> <p>ERROR MODE = Simulation didn't start due to and error during PC curve calculation in simulation modes ET or UI</p> <p>ERROR DAY = Simulation didn't due to and error during PC curve calculation in simulation modes DAYET or DAYUI</p> <p>ERROR ALARM = Simulation has stopped due to a device alarm</p> <p>ERROR INTERPOLATION = Simulation not started due to a wrong dwell time value in day trend data index 1</p>
FUNCtion:PHOTovoltaics:DAY:NUMBer?	Number of accepted day trend indexes. When transferring day trend data to the device, this counter counts up every time an index is successfully transferred and accepted. Can ve used to verify written data.
FUNCtion:PHOTovoltaics:OCVoltage?	Open circuit voltage of the simulated solar panel, calculated with a formula according to the standard. The values is affected by the selected simulation mode, the standard panel parameters (see below) and the calculation factors (also see below).
FUNCtion:PHOTovoltaics:SCCurrent?	Short-circuit current of the simulated solar panel, calculated with a formula according to the standard. The values is affected by the selected simulation mode, the standard panel parameters (see below) and the calculation factors (also see below).

ModBus & SCPI

5.4.17.5 Parameter commands

The commands listed below are used to set or read all the values required for the different PV simulation modes and the PV curve calculation. Not all commands can be written. When trying to write values it's important what simulation mode (ET, UI, DAYET, DAYUI) and what input mode (MPP, ULIK) is currently set. The matrix below indicates what command are supported in what mode. A third setting, the technology (MAN, CSI, THIN) also determines if a specific parameter is locked from writing, but instead is internally setup with a value according to the DIN EN 50530 standard. Reading the parameters is possible anytime and in every mode.

Command	Writable in modes:				
	MPP	ULIK	MAN	CSI	THIN
FUNCTION:PHOTOvoltaics:FACTor:FFU_<NRf> FUNCTION:PHOTOvoltaics:FACTor:FFU? Fill factor for voltage (FF _U). Only writable in technology selection MAN. Has impact on the PV curve calculation with formula according to standard. Range: >0...1	✓	✓	✓	—	—
FUNCTION:PHOTOvoltaics:FACTor:FFI_<NRf> FUNCTION:PHOTOvoltaics:FACTor:FFI? Fill factor for current (FF _I). Only writable in technology selection MAN. Has impact on the PV curve calculation with formula according to standard. Range: >0...1	✓	✓	✓	—	—
FUNCTION:PHOTOvoltaics:FACTor:ALPHA_<NRf> FUNCTION:PHOTOvoltaics:FACTor:ALPHA? Temperature coefficient α (in 1/°C) for the short-circuit current. Only writable in technology selection MAN. Has impact on the PV curve calculation with formula according to standard. Range: >0...1	✓	✓	✓	—	—
FUNCTION:PHOTOvoltaics:FACTor:BETA_<NRf> FUNCTION:PHOTOvoltaics:FACTor:BETA? Temperature coefficient β (in 1/°C) for the open circuit voltage. Only writable in technology selection MAN. Has impact on the PV curve calculation with formula according to standard. Range: -1...<0	✓	✓	✓	—	—
FUNCTION:PHOTOvoltaics:FACTor:CU_<NRf> FUNCTION:PHOTOvoltaics:FACTor:CU? Scaling factor C _U for the open circuit voltage. Only writable in technology selection MAN. Has impact on the PV curve calculation with formula according to standard. Range: >0...1	✓	✓	✓	—	—
FUNCTION:PHOTOvoltaics:FACTor:CR_<NRf> FUNCTION:PHOTOvoltaics:FACTor:CR? Scaling factor C _R in m ² /W or the open circuit voltage. Only writable in technology selection MAN. Has impact on the PV curve calculation with formula according to standard. Range: >0...1	✓	✓	✓	—	—
FUNCTION:PHOTOvoltaics:FACTor:CG_<NRf> FUNCTION:PHOTOvoltaics:FACTor:CG? Scaling factor C _G in W/m ² for the open circuit voltage. Only writable in technology selection MAN. Has impact on the PV curve calculation with formula according to standard. Range: >0...1	✓	✓	✓	—	—
FUNCTION:PHOTOvoltaics:STANdard:OCVoltage_<NRf> FUNCTION:PHOTOvoltaics:STANdard:OCVoltage? U _{OC} (open circuit voltage) of the simulated solar panel in V. Range: 0 - rated voltage	—	✓	✓	✓	✓
FUNCTION:PHOTOvoltaics:STANdard:SCCurrent_<NRf> FUNCTION:PHOTOvoltaics:STANdard:SCCurrent? I _{SC} (short-circuit current) of the simulated solar panel in A. Range: 0 - rated current	—	✓	✓	✓	✓
FUNCTION:PHOTOvoltaics:STANdard:MPP:VOLTage_<NRf> FUNCTION:PHOTOvoltaics:STANdard:MPP:VOLTage? Voltage in the MPP of the simulated solar panel, in V. Range: 0 - rated voltage	✓	—	✓	✓	✓
FUNCTION:PHOTOvoltaics:STANdard:MPP:CURREnt_<NRf> FUNCTION:PHOTOvoltaics:STANdard:MPP:CURREnt? Current in the MPP of the simulated solar panel, in A. Range: 0 - rated current	✓	—	✓	✓	✓

5.4.17.6 Control commands

These commands are to control the PV simulation, usually after the successful configuration. In some modes, one or two parameters are adjustable while the simulation is running. Any change of parameter requires to calculate the PV curve again, overwriting the former curve. Depending on what point on the curve the simulation currently is , the point will shift after a certain calculation and response time.

Command	Description
FUNCTION:PHOTOvoltaics:STATE_{RUN STOP} FUNCTION:PHOTOvoltaics:STATE?	Start/stop simulation RUN = Triggers PV curve calculation and succeeding simulation start, if there is no error occurring. If data recording is activated, it will also start STOP = Simulation and possibly running data recording are stopped
FUNCTION:PHOTOvoltaics:TEMPerature_<NR1> FUNCTION:PHOTOvoltaics:TEMPerature?	Only available in mode ET : Solar module temperature in °C. Range: -40...+80
FUNCTION:PHOTOvoltaics:IRRaditation_<NR1> FUNCTION:PHOTOvoltaics:IRRaditation?	Only available in mode ET : Irradiation in W/m ² . Range: 0-1500

5.4.17.7 Error situations

An error situation occurs when the configured simulation can't be started or it has started already and was running for a while, but then unexpectedly stopped. Command **FUNCTION:PHOTOvoltaics:STATE?** (see section 5.4.17.4) can help in both cases to identify the cause of the error.

Following generally applies:

- Once stopped for any reason, the simulation cannot be continued
- Data from the data recording feature can be read during the simulation or after the stop, as long as the device remains powered
- All configuration parameters are not stored and are reset when power-cycling the device

5.4.18 Commands for the battery test function

ELR9	ELR5	PS9	PSI9	PSI5	PS5	PSE	DT	PST	PSIT	EL3	PSB	PSBE	PS3
✓	–	–	–	–	–	–	✓(1)	–	–	✓	✓	–	–

(1 Except for PSI 9000 DT series)

Electronic load series and also bidirectional power supplies, which have a sink mode, feature a battery test function, which can be installed via firmware update for older production dates. With date 04-2019 remote battery test configuration and control is available for select series. It offers the almost same handling and settings as with manual control on the device. Additionally to the separate battery test modes for charging and discharging, series PSB 9000 offers a combined mode of both, called "Dynamic test" when manually operating it on the HMI. This mode has no extra commands for remote control, because it's achieved by combining both basic modes with timing. It means, on the PC side users can easily reconstruct the dynamic test mode.

5.4.18.1 Configuration command

The battery test configuration can be done in the same sequence of commands as listed by the table below. The very first thing to do is always to select the test mode between "static" and "dynamic".

Command	Description
[SOURce:]BATTery:MODE_{IDLE STATic DYNamic} [SOURce:]BATTery:MODE?	Select test mode: IDLE = no mode selected, function inactive (should be set when leaving the test mode) STATic = Select mode "static" DYNamic = Select mode "dynamic"

The following commands only work for sending or reading values after the mode (**STAT** or **DYN**) has been selected:

Command	Description
[SOURce:]BATTery:CURRent_{<NRf>}[Unit] [SOURce:]BATTery:CURRent?	Only for static mode: Set the (discharge) current in Amperes. The command does not work in mode DYN . Range: 0...I-max
[SOURce:]BATTery:POWer_{<NRf>}[Unit] [SOURce:]BATTery:POWer?	For static and dynamic mode: Set the maximum power in Watts. Constant power regulation can override constant current, so it may adjust the discharge current according to $I = P/U$ to lower than defined by BATT:CURR . Range: 0...P-max
[SOURce:]BATTery:RESistance_{<NRf>}[Unit] [SOURce:]BATTery:RESistance?	For static or dynamic mode: Switches resistance mode for the test on or off and set the resistance value in Ohms. Constant resistance regulation can override constant current, so it may adjust the discharge current according to $I = U/R$ to lower than defined by BATT:CURR . NRf = 0 = resistance mode off NRf = min. R ... max. R = set resistance

The below commands are for both test modes and define one or several stop conditions which can cause the battery test to stop automatically if any of these conditions becomes true:

Command	Description
[SOURce:]BATTery:DISCharge:VOLTage_{<NRf>}[Unit] [SOURce:]BATTery:DISCharge:VOLTage?	Defines the discharge voltage in Volts. Once the battery voltage reaches this threshold, the test will stop. Range: 0...U-max
[SOURce:]BATTery:DISCharge:CAPacity_{<NRf>}[Unit] [SOURce:]BATTery:DISCharge:CAPacity?	Defines the max. battery capacity to consume before the test can either stop or cause the device to write a message into its display. Range: 0...99999.99 Ah

ModBus & SCPI

Command	Description
[SOURce:]BATTery:ACTion:CAPacity_{ NONE SIGNAL END} [SOURce:]BATTery:ACTion:CAPacity?	Defines the action upon reaching the limit as defined by BATT:DIS:CAP . NONE = no action (the limit will be ignored) SIGNAL = test continues, but the device will signal that the limit has been reached END = test will be stopped
[SOURce:]BATTery:DIScharge:TIME_{NR1}>[Unit] [SOURce:]BATTery:DIScharge:TIME?	Defines the max. time to run the battery test, after which the test can either stop or cause the device to write a message into its display. Range: 0...36000 s
[SOURce:]BATTery:ACTion:TIME_{ NONE SIGNAL END} [SOURce:]BATTery:ACTion:TIME?	Same as BATT:ACT:CAP , but here for the max. test time as it can be defined with BATT:DIS:TIM .

When using the dynamic battery test mode, a pulsed current is generated which is defined by a rectangle with adjustable amplitude and duty cycle. The discharge current for this mode is thus defined from several command.

Following commands only work in mode **DYN**:

Command	Description
[SOURce:]BATTery:INDex_{0...3} [SOURce:]BATTery:INDex?	Select one out of 4 parameters upon which the rectangle for the pulsed current defines: 0 = Level 1 of the amplitude Range: 0...I-max (adjustment limit) 1 = Level 2 of the amplitude Range: 0...I-max (adjustment limit) 2 = Time of level 1 Range: 0...6000 s 3 = Time of level 2 Range: 0...6000 s
[SOURce:]BATTery:PULSe_{NRf / NR1}> [SOURce:]BATTery:PULSe?	Sets or reads the value from the index as previously selected with BATT:IND . Value for current amplitude can be given in format NRf , time value only in format NR1 .

5.4.18.2 Control and status commands

After successful battery test configuration the test can be started. Unless there will be no unexpected event such as an device alarm, the battery test will run and later stop upon the defined stop condition.

Command	Description
[SOURce:]BATTery:STATe_{ RUN STOP } [SOURce:]BATTery:STATe?	Starts the test or stops it manually and anytime before reaching a stop condition. RUN = Start test STOP = Stop test immediately
[SOURce:]BATTery:CONDition?	Queries the test condition. This can be done anytime, i.e. before, during or after the test. IDLE = test has not yet been started or has been stopped manually or due to an alarm RUN = test is running Further conditions (not yet featured with EL 3000 B): FINISHED = Test is finished ERROR = Test stopped due to device alarm SIGNAL AH = Max. allowed number of Ah reached, test continues SIGNAL TIME = Max. allowed test time reached, test continues END AH = Max. allowed number of Ah reached, test stopped END TIME = Max. allowed test time reached, test stopped

5.4.18.3 Test result commands

After test end, a few values can be read which represent the test result.

Command	Description
[SOURce:]BATTery:TEST?	Queries the test results. It should return a string with three values. Can also be queried while the test is running: <ol style="list-style-type: none">1. Consumed capacity in Ah (only from discharging)2. Consumed energy in Wh (only from discharging)3. Elapsed battery test time

5.5 Example applications

5.5.1 Configure and control master-slave with SCPI

ELR9	ELR5	PS9	PSI9	PSI5	PSE	DT	PST	PSIT	EL3	PSB	PSBE	PS3
✓	–	–	✓	–	✓	–	–	–	–	✓	✓	–

Certain device series which feature true master-slave (short: MS) with total formation via a dedicated master-slave bus also support the full remote configuration and control of the system. In a MS system, usually only the master unit is remotely controlled, while the slaves are usually not connected to the PC, except for the moment when being configured remotely as slave. It's thus recommended to configure the MS system on the control panels of the units and only put the master into remote control via any software. Even if you would configure all units manually on the control panel, the remote control software could later read the status of the MS init from the master. The initialisation of the MS system is done automatically every time the master is powered, but can be triggered and repeated by command.

Let's assume following example configuration: five power supplies **PSI 9080-510 3U** (80 V, 510 A, 15 kW) in parallel. The master has to display itself as an 80V, 2550 A, 75 kW and 1 Ω unit after successful configuration and initialisation. These values are also the temporary new ratings of the MS system. The same way as with manual control, the "Limits" and set values can be adjusted in 0...102% of the rated value, while protection values have range of 0..110% or 0...103%.

The exemplary step-by-step guide below is separated into steps, because some steps are optional.

Part 1a: Configure the master

1. Activate remote control: **SYST:LOCK_ON**
2. Activate master-slave mode: **SYST:MS:ENABLE_ON**
3. Define the unit as master: **SYST:MS:LINK_MASTER**
4. (when running two-quadrants operation and the master in an electronic load):
Set the master as Share bus slave: **SYST:SHAR:LINK_SLAVE**

Part 1b: Configure the slave(s), in case it's connected to the controlling unit (PC, PLC etc.)

5. Activate remote control: **SYST:LOCK_ON**
6. Activate master-slave mode: **SYST:MS:ENABLE_ON**
7. Define the unit as slave: **SYST:MS:LINK_SLAVE**

If there is more than one slave, repeat steps 5-7 for the other slave(s) with their own addresses.

Part 2: Initialise the MS system

8. Activate remote control, in steps 1-7 were not processed, because system was already configured: **SYST:LOCK_ON**
9. Trigger initialisation, then wait a few seconds: **SYST:MS:INIT**

Part 3: Further, optional steps

10. Query the initialisation status from the master, in order to analyse it: **SYST:MS:COND?**
11. Query the number of units initialised for the MS system (should be 5 with this example): **SYST:MS:UNIT?**
12. Query the nominal current of the MS system: **SYST:NOM:CURR?**
13. Query the nominal power of the MS system: **SYST:NOM:POW?**
14. Query the maximum resistance of the MS system: **SYST:NOM:RES:MAX?**
15. Query the minimum resistance of the MS system: **SYST:NOM:RES:MIN?**
16. Configure protection values, for example OCP: **CURR:PROT_400**
17. Configure events, for example,
 - set OCD to 2100 A: **SYST:CONF:OCD_2100**
 - then define the alarm type for OCD to "warning": **SYST:CONF:OCD:ACT_WARNING**

The adjustment limits ("Limits") require extra treatment, because they are tied to the set values. Means, with the set values being reset to defaults during the MS init, for example the set value of current would be at maximum and thus the related adjustment limit I_{Max} can't be set lower than this without prior changing the set value.

18. Narrow the adjustable range of values, for example limit the max. current set value to 2200 A
 - First, set the current value down to anything lower than the desired limit, like the minimum: **CURR_MIN**
 - Second, set the adjustment limit to the value translated for the master unit: **CURR:LIM:HIGH_2200**

ModBus & SCPI

With these settings applied, the current should be at 0, because the lower adjust limit has not yet been changed. The current will be monitored for the threshold of 2100 A by the event system and since it's adjustable up to 2200 A, the true current might exceed the threshold and cause an OCD event, which would only generate a warning on screen, but not switch off the DC output.

19. To start working with your MS system, switch the DC output on: **OUTP_ON**

The system will remain configured and keep the settings when power-cycling it. The master unit has to initialise the MS and the slaves at least one time after power-up. The status of the first automatic initialisation can be read from the master by custom software and depending on the result, the software could trigger further steps like the ones above, probably from at least step 8 or if required even from step 1.

5.5.2 Programming examples for the function generator

5.5.2.1 General command sequence for the arbitrary generator

ELR9	ELR5	PS9	PSI9	PSI5	PSE	DT	PST	PSIT	EL3	PSB	PSBE	PS3
✓	–	–	✓	–	–	✓	–	✓	–	✓	–	–

Let's say you want to apply a sine wave with 30 A amplitude and 10 Hz frequency for 60 s to the DC input current of an electronic load. This can be achieved by setting up just one sequence. Let's use sequence number 12. Because this is about DC current, the amplitude also requires an offset. The amplitude is usually understood as the difference between the base line, which is here defined by Start(DC) and End(DC) values, and the top value of the sine wave. In this example, the offset then has to be at least 30 A, so let's say 50 A. This will result in a DC input current varying sinusoidally between 20 A and 80 A.

The sine wave, when applied to DC voltage or current, emulates AC characteristics and thus requires to set at least indexes 0, 1, 2, 3, 5, 6 and 7, according to the table above. As long as no specific start angle is required, index 4 can be skipped, because the default value is 0°.



Setting the global set values to maximum or any other value is also necessary when using the function generator, especially when running multiple devices in master-slave where those set values are used to limit the slaves.

Given that the device is already in remote control and the DC input resp. DC output is off, following command sequence would be necessary:

No.	Command	Description
1	FUNC:GEN:SEL CURRENT	Selects arbitrary generator for current. By sending this command the device will switch to function generator mode
2	FUNC:GEN:WAVE:LEVEL_12	Selects the 12th sequence for writing values
3	FUNC:GEN:WAVE:IND_5	Select index 5: Start value of DC part or AC offset
4	FUNC:GEN:WAVE:DATA_50	Set wave offset to 50 A
5	FUNC:GEN:WAVE:IND_6	Select index 6: End value of DC part or AC offset
6	FUNC:GEN:WAVE:DATA_50	Set wave offset to 50 A. If the offset shall not change during the function run, end and start value have to be identical.
7	FUNC:GEN:WAVE:IND_2	Select index 2: Start frequency of sine wave
8	FUNC:GEN:WAVE:DATA_10	Set start frequency to 10 Hz
9	FUNC:GEN:WAVE:IND_3	Select index 3: End frequency of sine wave
10	FUNC:GEN:WAVE:DATA_10	Set end frequency to 10 Hz. If the frequency shall not change during the function run, end and start value have to be identical.
11	FUNC:GEN:WAVE:IND_0	Select index 0: Start value of sine wave amplitude
12	FUNC:GEN:WAVE:DATA_30	Set amplitude to 30 A
13	FUNC:GEN:WAVE:IND_1	Select index 1: End value of sine wave amplitude
14	FUNC:GEN:WAVE:DATA_30	Set amplitude to 30 A. If the amplitude shall not change during the function run, end and start value have to be identical.
15	FUNC:GEN:WAVE:IND_7	Select index 7: Sequence time
16	FUNC:GEN:WAVE:DATA_60	Set sequence point time to 60 s
17	FUNC:GEN:WAVE:END_12	Set end sequence point to 12
18	FUNC:GEN:WAVE:START_12	Set start sequence point to 12

ModBus & SCPI

No.	Command	Description
19	FUNC:GEN:WAVE:NUM_1	Set number of sequence point cycles to 1, because that one sequence point will already run for 60 s. Alternatively, it's possible to define 1 s for the sequence point time and let it run through 60 cycles.
20	FUNC:GEN:WAVE:SUBMIT	Load the parameters from above into the function generator

Now you also need to set the three global set values "U/I/P Limits", as you would set them in manual control. This is required, because in function generator mode, the set values of U, I and P from normal operation are not used. In this example with a current sink (i.e. electronic load), it's recommended to set the voltage to 0 V, the power to maximum and the current to 105% or higher of the peak that would result from the sine wave current.

No.	Command	Description
21	VOLT_0	Set voltage to 0 V, so the device can clearly operate in current control mode
22	CURR_88	The current peak of this example is calculated as 80 A, so we set 110%, means 88 A
23	POW_MAX	Power to max, independent from the model

The function generator is now configured and sequence 12 is set up. You may start to function generator now and control it remotely:

No.	Command	Description
24	INP_ON OUTP_ON	Switch the DC input resp. DC output of your device on
25	FUNC:GEN:WAVE:STAT_RUN	Start the function with RUN. After 60 s, the function will stop.
26	FUNC:GEN:WAVE:STAT_STOP	Stop/abort function run. The DC input/output will remain on at first and can be switched off with the dedicated command, if necessary
27	FUNC:GEN:SEL_NONE	Parameter NONE will leave function generator mode

5.5.2.2 Command sequence for the XY generator

ELR9	ELR5	PS9	PSI9	PSI5	PSE	DT	PST	PSIT	EL3	PSB	PSBE	PS3
✓	–	–	✓	–	–	–	–	✓	–	✓	–	–

Configuration and loading of table data for the XY generator is very similar to the procedure of the arbitrary generator. Let's say you want to have the DC input current of an electronic load react to the input voltage. This is where the XY generator suits well with its IU function.

The IU table with its data determines the current to draw from the source for the entire input voltage range (0...125% U_{Nom}), which is resolved in 4096 values. With this you can define everything you want, like for example the current to remain 0 A below a certain input voltage threshold. The desired current curve could be created in Excel or similar tools and exported as CSV file. Because the measurement range of the referenced values is defined as 0...125% (of the rated value), but for the depending value it's only 0...100%, the 100% for the depending value is at table entry $4096/1.25 = 3276$.

There is furthermore a global power limitation, so the device can not make 100% voltage at 100% current. When creating the table in Excel or similar, it might help to add another two columns (which are later not exported to CSV, of course). One column, where the referenced value is distributed between 0...125% nominal value over the 4096 entries, and another where the power is calculated for every entry ($P = U * I$), to find out which of the entries could not be physically realised by the device.



Caution! It's not advisable to have big value differences between two or a group of consecutive table entries. Rather use values that change voltage/current less abrupt.

No.	Command	Description
1	FUNC:GEN:SEL_IU Alternatively for PSB 9000 and PSB 10000 series: FUNC:GEN:SEL_IUPS FUNC:GEN:SEL_IUEL	Select the IU function for the XY generator use: $I = f(U)$. By sending this command the device will switch to function generator mode. IU table only in source mode IU table only in sink mode
2	FUNC:GEN:XY:LEVEL_0	Select table entry 0 for writing

ModBus & SCPI

No.	Command	Description
3	FUNC:GEN:XY:DATA_0	Write a current value to the table entry, here: 0 A (random value)
...		
8192	FUNC:GEN:XY:LEVEL_4095	Select table entry 4095 for writing
8193	FUNC:GEN:XY:DATA_120	Write a current value to the table entry, here: 120 A (example)
8194	FUNC:GEN:XY:SUBMIT	Submit all data

Now it's advised to also define the set values which are not affected by the table, else the function would run without any effect. It means, if you load an UI table, the voltage is set from values in the table, but current and power are static and the values you can adjust for U, I and P in normal operation are not effective here.

For an IU table, voltage and power are static. You can set the static values to any value you like, but in order for the static set values not to interfere in the UI or IU function run, it's recommended to set both to maximum:

No.	Command	Description
8195	VOLT_MAX resp. CURR_MAX	Set voltage and current to maximum. You may also chose any other value which should be at least as high as the biggest value in the XY table.
8196	POW_MAX	Power to max, independent from the model
	Additionally for PSB 9000 and PSB 10000 series: SINK:CURR_MAX SINK:POW_MAX	Only required for IU and IUEL modes where the PSB device either only works in sink mode or can enter sink mode

After this, the function generator is configured and the IU table is loaded. Now the function can be started by remotely controlling the generator:

No.	Command	Description
8197	INP_ON OUTP_ON	Switch the DC input resp. DC output of your device on
8198	INP_OFF OUTP_OFF	Switch the DC input resp. DC output of your device off to make the function stop
8199	FUNC:GEN:SEL_NONE	Parameter NONE selects no function generator type and leaves the function generator mode

5.5.2.3 Command sequence to generate a rising ramp (arbitrary generator)

ELR9	ELR5	PS9	PSI9	PSI5	PSE	DT	PST	PSIT	EL3	PSB	PSBE	PS3
✓	–	–	✓	–	–	✓	–	✓	–	✓	–	–

Before you can configure the arbitrary generator for a ramp it's necessary to think about the best way to achieve the ramp generation. It's important to keep in mind that the arbitrary generator stops at the end of the function run, unless you set the repetition to infinite. After a stop, the DC input/output remains switched on. In case of a ramp, this is wanted, because the end value shall usually remain set for time x. However, the device will go to static mode again, setting the static set values of U, I and P. The static values also apply for the period before the function run and when the DC output/input is already switched on.

The stop action and the static values are thus a little problematic for the ramp function. Why? Supposed that you wanted to have a power supply generate a ramp starting from 0 V. The static value for U (voltage) would then be set to 0. But after the function stop, the device would also set 0 V and the voltage would drop from whatever value has been set during the function run. Conclusion: the static value of voltage has to part of the function.

In order to achieve this, the function has to consist of two parts: one for the rising or falling ramp and the other for the static value. This can be done using two sequence points of the arbitrary generator.

Assumption: the ramp shall start from 0 V and rise to 50 V within 6 seconds. The end voltage shall remain constant for 3 minutes (the time can be varied at will). We are going to use sequence points 1 and 2. Remote control is already active, we only need to configure. Since the ramp will make the voltage rise linearly, using only the DC part of a sequence point, the parameters for the AC part (indexes 0 - 4) should be set to zero, in order to avoid remainders of wrongly set AC parameters to disturb the correct wave generation. The commands need for this are not listed for this example.

ModBus & SCPI

Sequence point 1, rising ramp

No.	Command	Description
1	FUNC:GEN:SEL_VOLTAGE	Selects arbitrary generator for voltage. By sending this command the device will switch to function generator mode
2	FUNC:GEN:WAVE:LEVEL_1	Select sequence 1 for writing
3	FUNC:GEN:WAVE:IND_5	Select index 5: Start voltage of the ramp
4	FUNC:GEN:WAVE:DATA_0	Set start voltage to 0 V
5	FUNC:GEN:WAVE:IND_6	Select index 6: End voltage of the ramp
6	FUNC:GEN:WAVE:DATA_50	Set end voltage to 50 V
7	FUNC:GEN:WAVE:IND_7	Select index 7: Ramp duration
8	FUNC:GEN:WAVE:DATA_6	Set 6 seconds

Sequence point 2, the static voltage at the ramp end

No.	Command	Description
9	FUNC:GEN:WAVE:LEVEL_2	Select sequence 2 for writing
10	FUNC:GEN:WAVE:IND_5	Select index 5: Start value of the static voltage (ramp without slope)
11	FUNC:GEN:WAVE:DATA_50	Set start voltage to 50 V
12	FUNC:GEN:WAVE:IND_6	Select index 6: End value of the static voltage (ramp without slope)
13	FUNC:GEN:WAVE:DATA_50	Set end voltage to 50 V
14	FUNC:GEN:WAVE:IND_7	Select index 7: Duration
15	FUNC:GEN:WAVE:DATA_180	Set to 3 minutes (180 seconds)

Configuring the arbitrary generator

No.	Command	Description
16	FUNC:GEN:WAVE:END_2	Set sequence 2 as end sequence
17	FUNC:GEN:WAVE:START_1	Set sequence 1 as start sequence
18	FUNC:GEN:WAVE:NUM_1	Number of cycles
19	FUNC:GEN:WAVE:SUBMIT	Submit all data

The number of cycles is set to 1, so the function runs once and then stops. The value can be changed at will, but with every repetition after 3 m 6 s, the voltage of the ramp would have to drop from 50 V to 0 V, where the ramp shall start. But it cannot drop in zero time. How long it takes primarily depends on the connected load (supposed you are using a power supply). The resulting ramp could be malformed more or less. In order to avoid that a third sequence could be configured which just gives the voltage some time to drop.

After this the ramp function is fully configured and can be started. If the DC output/input is not yet switched on, it will be automatically switched on when running the function. Alternatively, switching it on can also be done separately with the corresponding commands. Here it's not required, because the function starts from 0 V, but in case a function shall not start at 0, it would be necessary to switch on the DC output/input first.

No.	Command	Description
20	FUNC:GEN:WAVE:STAT_RUN	Run the function generator

Without repetition the function would stop after one run and after the time defined in sequencepoint 2 (ignoring the duration of sequence point 1 here, because only 6 s) and the voltage would drop to zero. If you wanted to have the static value remain set for much longer, you would probably need to include the remaining 97 sequence points. With one sequence point you can achieve a duration of 10 h, so the static value could remain set for a maximum of $99 \times 10 \text{ h} = 990 \text{ h}$.



If you want to generate a ramp where the start value is not 0, it must be decided whether to set the corresponding set value of voltage or current to the same level as the start value, so the function would not cause a step, or to any other value, such as 0, so the device would not provide voltage or current before the actual start of the function.

ModBus & SCPI

5.5.3 Programming examples for PV simulation (DIN EN 50530)

ELR9	ELR5	PS9	PSI9	PSI5	PSE	DT	PST	PSIT	EL3	PSB	PSBE	PS3
-	-	-	✓	-	-	-	-	-	-	✓	-	-

Further information about this extended PV function can be found in the user manuals of your device, as well as the norm paper. The user manuals also teach about the connection between simulation mode, input mode and panel technology.



Important: after the simulation start the device will calculate the first PV curve table. This takes about 500 ms, so the actual simulation begins ~ 500 ms after the start.

Overview (an "x" marks a possible combination):

Simulation mode \ Options	Input mode ULIK	Input mode MPP
ET	x	x (example 1)
UI		x (example 3)
DAY ET	x (example 2)	x
DAY UI		x (example 4)

5.5.3.1 Example 1

- Technology: cSi
- Input mode: MPP values
- Simulation mode: Continuous, with adjustable temperature and irradiation
- Recording: activated

Configuration

Nr.	Command	Description	Register
1	SYST:LOCK_ON	Activate remote control	402
2	FUNC:PHOT:MODE_ET	Activate PV simulation mode ET	12001
3	FUNC:PHOT:TECH_CSI	Select technology: cSi	12016
4	FUNC:PHOT:IMOD_MPP	Select input mode: MPP	12017
5	FUNC:PHOT:STAN:MPP:VOLT_20	Set MPP voltage: 20 V	12050
6	FUNC:PHOT:STAN:MPP:CURR_5	Set MPP current: 5 A	12051
7	FUNC:PHOT:REC:ACT_ENABLE	Activate data recording	12018
8	POW_MAX	Set global power set value to maximum	502
9	VOLT 30	Set the global voltage limit (should be higher than Uoc)	500



- The values for the standard test condition (STC), as set in steps 5 and 6, are only used to calculate the first PV curve. The MPP values (:STAN:MPP) are linked to the solar panel specs Uoc (:STAN:OCV) and Isc (:STAN:SCC) via the factors FFi and FFu. They overwrite each other. It means, that setting :STAN:MPP:VOLT overwrites the value in :STAN:OCV and vice versa
- Voltage and current in the MPP are connected via factors FFi and FFu to the open circuit voltage (Uoc) and the short-circuit current (Isc). Depending on the selected technology, these factors are not adjustable
- The first curve after function start is calculated with the default values $T = 25^{\circ}\text{C}$ and $E = 1000 \text{ W/m}^2$ ($E =$ from german "Einstrahlung" -> irradiation)

Control (also during simulation run)

Nr.	Command	Description	Register
10	FUNC:PHOT:STAT_RUN	Start simulation	12000
11	FUNC:PHOT:TEMP_40	Adjust temperature value: 40 °C	12052
12	FUNC:PHOT:IRR_800	Adjust irradiation: 800 W/m ²	12053
13	FUNC:PHOT:STAT_STOP	Stop simulation after an arbitrary time	12000

ModBus & SCPI

Analysis after simulation end

Nr.	Command	Description	Register
14	FUNC:PHOT:REC:NUMB?	Read number (n) of recorded data sets	12020
15	FUNC:PHOT:REC:IND_1	Select first data set (index 1) for reading	12022
16	FUNC:PHOT:REC:DATA?	Read data from data set (index) 1	12024
...	...	Read further n-1 data sets:	...
x	FUNC:PHOT:REC:IND_n	Select data set n (index n) for reading	12022
y	FUNC:PHOT:REC:DATA?	Read data from data set (index) n	12024

5.5.3.2 Example 2

- Technology: Manual
- Input mode: Open circuit voltage and short-circuit current
- Simulation mode: Day trend with adjustable temperature and irradiation
- Interpolation: deactivated
- Data recording: activated

Configuration

Nr.	Command	Description	Register
1	SYST:LOCK_ON	Activate remote control	402
2	FUNC:PHOT:MODE_DAYET	Activate PV simulation mode DAY ET	12001
3	FUNC:PHOT:TECH_MAN	Select technology: Manual (all required parameters must be defined, here as with commands 4-10)	12016
4	FUNC:PHOT:FACT:FFU_0.8	Fill factor voltage (FF_U): 0,8	12034
5	FUNC:PHOT:FACT:FFI_0.78	Fill factor current (FF_I): 0,78	12036
6	FUNC:PHOT:FACT:ALPH_0.0003	Temperature coefficient α for I_{SC} : 0,0003 /°C	12038
7	FUNC:PHOT:FACT:BETA_-0.003	Temperature coefficient β for U_{OC} : -0,003 /°C	12040
8	FUNC:PHOT:FACT:CU_0.0725	Scaling factor C_U for U_{OC} : 0,0725	12042
9	FUNC:PHOT:FACT:CR_0.00022	Scaling factor C_R for U_{OC} : 0,00022 m ² /W	12044
10	FUNC:PHOT:FACT:CG_0.00315	Scaling factor C_G for U_{OC} : 0,00315 W/m ²	12046
11	FUNC:PHOT:IMOD_ULIK	Select input mode: ULIK	12017
12	FUNC:PHOT:STAN:OCV_38	Set open circuit voltage: 38 V	12048
13	FUNC:PHOT:STAN:SCC_7	Set short-circuit current: 7 A	12049
14	FUNC:PHOT:REC:ACT_ENABLE	Activate data recording	12018
15	FUNC:PHOT:DAY:INT_OFF	Deactivate interpolation of day trend data	12005
16	POW_MAX	Set global power set value to maximum	502
17	VOLT 38	Set the global voltage limit (should be ≥U _{oc})	500



- The values for the standard test condition (STC), as set in steps 5 and 6, are only used to calculate the first PV curve. Every change of parameter that would shift the MPP causes the device to calculate the PV anew.
- Voltage and current in the MPP are connected via factors **FF_I** and **FF_U** to the open circuit voltage (**U_{oc}**) and the short-circuit current (**I_{sc}**), which are both given in this example, other than in Example 1. Depending on the selected technology, these factors are not adjustable

Write day trend data (only possible before the function start)

Nr.	Command	Description	Register
18	FUNC:PHOT:DAY:MODE_WRITE	Select access mode: write	12006
19	FUNC:PHOT:DAY_CLEAR	Delete former data (should be executed every time before loading new data)	12007

ModBus & SCPI

Nr.	Command	Description	Register
20	FUNC:PHOT:DAY:DATA_1,_500,_20,_1500	Write 1 st day trend data set: Irradiation: 500 W/m ² Temperature: 20°C Dwell time: 1500 ms	12010
		 <i>The dwell time is defined to have a minimum of 500 ms. However, when setting up the very first day trend data set it's expected to set 1000 ms or higher for this one, because else the function run might fail.</i>	
21	FUNC:PHOT:DAY:DATA_2,_800,_28,_1500	Write 2 nd day trend data set: Irradiation: 800 W/m ² Temperature: 28°C Dwell time: 1500 ms	12010
...	...	Write further data sets, a total of 500	...
519	FUNC:PHOT:DAY:DATA_500,_1200,_35,_20000	Write 500. day trend data set: Irradiation: 1200 W/m ² Temperature: 35°C Dwell time: 20000 ms	12010

Control

Nr.	Command	Description	Register
520	FUNC:PHOT:STAT_RUN	Start simulation -> the simulation will stop automatically after the time that results from the total of dwell times in all written data sets	12000

Analysis (after simulation end)

Nr.	Command	Description	Register
521	FUNC:PHOT:REC:NUMB?	Read number (n) of recorded data sets. This number is not related to the number of day trend data sets in use. This feature records a new data set every 100 ms. Depending on the total simulation time, the record buffer could fill (max. 16 h record time) and overwrite existing data. It may become necessary to calculate the total simulation time from the day trend data sets and start reading the recorded data during simulation, then clearing the buffer and later read the rest of data.	12020
522	FUNC:PHOT:REC:IND_1	Select first data set (index 1) for reading	12022
523	FUNC:PHOT:REC:DATA?	Read data from data set (index) 1	12024
...	...	Read further n-1 data sets:	...
x	FUNC:PHOT:REC:IND_n	Select data set n (index n) for reading	12022
y	FUNC:PHOT:REC:DATA?	Read data from data set (index) n	12024

5.5.3.3 Example 3

- Technology: thin film
- Input mode: MPP values
- Simulation mode: Continuous, with adjustable MPP (voltage and current)
- Recording: deactivated

Configuration

Nr.	Command	Description	Register
1	SYST:LOCK_ON	Activate remote control	402
2	FUNC:PHOT:MODE_UI	Activate PV simulation mode UI	12001
3	FUNC:PHOT:TECH_THIN	Select technology: Thin film	12016
4	FUNC:PHOT:IMOD_MPP	Select input mode: MPP	12017
5	FUNC:PHOT:STAN:MPP:VOLT_45	Set MPP voltage: 45 V	12050

ModBus & SCPI

Nr.	Command	Description	Register
6	FUNC:PHOT:STAN:MPP:CURR_10	Set MPP current: 10 A	12051
7	FUNC:PHOT:REC:ACT_DISABLE	Deactivate data recording	12018
8	POW_MAX	Set global power set value to maximum	502
9	VOLT 57	Set the global voltage limit (should be $\geq U_{oc}$)	500

Control (also during simulation run)

Nr.	Command	Description	Register
10	FUNC:PHOT:STAT_RUN	Start simulation	12000
11	FUNC:PHOT:STAN:MPP:VOLT_40	Shift MPP: 40 V	12050
12	FUNC:PHOT:STAN:MPP:CURR_9	Shift MPP: 9 A	12051
13	FUNC:PHOT:STAT_STOP	Stop simulation after an arbitrary time	12000

5.5.3.4 Example 4

- Technology: cSi
- Input mode: MPP values
- Simulation mode: Day trend with shiftable MPP (voltage and current)
- Interpolation: activated
- Data recording: deactivated

Configuration

Nr.	Command	Description	Register
1	SYST:LOCK_ON	Activate remote control	402
2	FUNC:PHOT:MODE_DAYUI	Activate PV simulation mode DAY UI	12001
3	FUNC:PHOT:TECH_CSI	Select technology: cSi	12016
4	FUNC:PHOT:IMOD_MPP	Select input mode: MPP	12017
5	FUNC:PHOT:STAN:MPP:VOLT_36	Set open circuit voltage: 36 V	12050
6	FUNC:PHOT:STAN:MPP:CURR_12	Set short-circuit current: 12 A	12051
7	FUNC:PHOT:REC:ACT_DISABLE	Deactivate data recording	12018
8	FUNC:PHOT:DAY:INT_ON	Activate interpolation of day trend data	12005
9	POW_MAX	Set global power set value to maximum	502
10	VOLT 57	Set the global voltage limit (should be $\geq U_{oc}$)	500

Load day trend data (only possible before the function start)

Nr.	Command	Description	Register
11	FUNC:PHOT:DAY:MODE_WRITE	Select access mode: write	12006
12	FUNC:PHOT:DAY_CLEAR	Delete former data (should be executed every time before loading new data)	12007
13	FUNC:PHOT:DAY:DATA_1,1,1,300000	Write 1 st day trend data set: MPP voltage: 1 V MPP current: 1 A Dwell time: 300 seconds => 5 minutes	12010
14	FUNC:PHOT:DAY:DATA_2,2,2,500	Write 2 nd day trend data set: MPP voltage: 2 V MPP current: 2 A	12010
...	...	Write further data set, a total of 1000	...
1012	FUNC:PHOT:DAY:DATA_1000,9,500	Write 1000th day trend data set: MPP voltage: 30 V MPP current: 9 A	12010

ModBus & SCPI

Due to the dwell time of 5 minutes in the very first day trend data set, all 1000 data sets use the same dwell time, so the total simulation time results as 5000 minutes.

Control

Nr.	Command	Description	Register
1013	FUNC:PHOT:STAT_RUN	Start simulation -> the simulation will stop automatically after the time that results from the total of dwell times in all written data sets	12000

5.5.4 Programming examples for MPP tracking

ELR9	ELR5	PS9	PSI9	PSI5	PSE	DT	PST	PSIT	EL3	PSB	PSBE	PS3
✓	✓	-	-	-	-	✓	-	-	✓	✓	-	-

5.5.4.1 MPP2

For MPP tracking related information also refer to the user manual of your device. It explains how the different modes work and what the parameters are. Modes 1 to 3 don't require to load user data.

The parameters, as set in the configuration part, are invariable during runtime.

Configuration

Nr.	Command	Description	Register
1	SYST:LOCK_ON	Activate remote control	402
2	FUNC:GEN:MPP:IND_0	Index 0 is used to activate MPP mode selection	11000
3	FUNC:GEN:MPP:DATA_MPP2	Select mode MPP2 ("track"). This mode does not stop automatically.	11000
4	FUNC:GEN:MPP:IND_1	Index 1 = Select to set the open circuit voltage U_{OC} of the solar panel to which the device is connected. This value also defines the voltage limit of the device.	11001
5	FUNC:GEN:MPP:DATA_50	Set U_{OC} to 50 V.	11001
6	FUNC:GEN:MPP:IND_2	Index 2 = Select to set the short-circuit current I_{SC} of the solar panel to which the device is connected. This value also defines the current limit of the device.	11002
7	FUNC:GEN:MPP:DATA_100	Set I_{SC} to 100 A	11002
8	FUNC:GEN:MPP:IND_10	Index 10 = Select to set the tracking interval Δt in milliseconds. This time elapses before the next tracking attempt.	11013
9	FUNC:GEN:MPP:DATA_3000	Time = 3 s	11013
10	FUNC:GEN:MPP:IND_6	Index 6 = Select to set ΔP , an offset to P_{MPP} where the device would start the next tracking attempt when this offset has been exceeded	11006
11	FUNC:GEN:MPP:DATA_30	Set ΔP to 30 W (series with a low power rating have an adjustment range of 0-50 W [see the device's user manual for the actual range], other series have 0- P_{Nom})	11006

Control

Nr.	Command	Description	Register
12	FUNC:GEN:MPP:STAT_RUN	Start the tracking -> the device will attempt to find the MPP and then track it until stopped, because this mode doesn't stop automatically. The time difference between two tracking attempts is defined by index 10, the max. deviation of the actual power from the MPP, before the tracking would continue, is defined via index 6. The last successful action to track the MPP stores three values U_{MPP} , I_{MPP} and P_{MPP} which can be read during runtime or later.	11010
13	FUNC:GEN:MPP:STAT_STOP	Stop tracking anytime	11010

ModBus & SCPI

Analysis

Nr.	Command	Description	Register
14	FUNC:GEN:MPP:IND_7	Index 7 = Set read mode for MPP data	11007
13	FUNC:GEN:MPP:DATA?	Read the MPP values U_{MPP} , I_{MPP} and P_{MPP}	11008 11009

5.5.4.2 MPP4

This mode is different to the others. It's available in remote control for all series, but not all of them support to use MPP4 on the control panel (HMI), so this mode is not explained in these series' user manual. In case you have such a device and need more information, refer to the user manual of series EL 9000 B 3U, for example.

With this mode, also called "user curve", the device runs 1-100 arbitrarily definable points (voltage values) on an user defined curve, that could represent a PV curve of a solar panel. The goal is to collect measured data and to find the MPP amongst that data. For every processed curve point the device will present readable data in form of MPP values (U, I, P). The actual MPP, derived from all collected data, is also presented as a readable set of data.

In the example it shows how to configure and load 75 user defined points for MPP4 mode.

Configuration

Nr.	Command	Description	Register
1	SYST:LOCK_ON	Activate remote control	402
2	FUNC:GEN:MPP:IND_0	Index 0 is used to activate MPP mode selection	11000
3	FUNC:GEN:MPP:DATA_MPP4	Select mode MPP4 ("user curve"). This mode will stop automatically.	11000
4	FUNC:GEN:MPP:IND_8	Index 1 = Activate user data input mode	11100 - 11174
5	FUNC:GEN:MPP:LEV_1	Level 1 = 1 st point of user curve	
6	FUNC:GEN:MPP:DATA_100	Set 1 st point to 100 V	
...		Set further ideally subsequent points	
153	FUNC:GEN:MPP:LEV_75	Level 75 = 75 th point of user curve	
154	FUNC:GEN:MPP:DATA_80	Set 75 th point to 80 V	
155	FUNC:GEN:MPP:IND_12	Index 12 = Select to define the range of points to run through in the test (here: end point). The end point can be any of 100 available points. Since the start point cannot be higher than the end point, the end point is set first.	11015
156	FUNC:GEN:MPP:DATA_75	End point = 75	11015
157	FUNC:GEN:MPP:IND_11	Index 11 = Select to define the range of points to run through in the test (here: start point). The start point can be any of 100 available points, but must not be higher than the end point.	11014
158	FUNC:GEN:MPP:DATA_1	Start point = 1	11014
159	FUNC:GEN:MPP:IND_10	Index 10 = Select to set the tracking interval Δt , in milliseconds. Defines the time to elapse before proceeding to the next point.	11013
160	FUNC:GEN:MPP:DATA_500	Time = 0.5 s	11013
161	FUNC:GEN:MPP:IND_13	Index 13 = Select to set the repetitions (0-65535) of the curve run. The result data, which can be read later, only holds the results of the last run.	11016
162	FUNC:GEN:MPP:DATA_0	Repetitions = 0 (only one cycle)	11016



Any point that is within the defined range of points to run through and that hasn't been loaded, it processed with 0 V.

ModBus & SCPI

Control

Nr.	Command	Description	Register
163	FUNC:GEN:MPP:STAT_RUN	Start tracking -> the device will pick the first point of the defined range, set the voltage and measures current and power, stores all three and continues with the next etc. After all points and all cycles are through, the data is scanned for the point with the highest power, which is separately presented as MPP.	11010

Analysis

Nr.	Command	Description	Register
164	FUNC:GEN:MPP:IND_9	Index 9 = Set mode to read the MPP4 measurings	11200 - 11274
165	FUNC:GEN:MPP:LEV_1	Select 1 st point to read from the list of measurings	
166	FUNC:GEN:MPP:DATA?	Read 1 st point as U_{MPP} , I_{MPP} and P_{MPP}	
...		Continuously read further points	
313	FUNC:GEN:MPP:LEV_75	Select 75 th point to read from the list of measurings	11007 11008 11009
314	FUNC:GEN:MPP:DATA?	Read 75 th point as U_{MPP} , I_{MPP} and P_{MPP}	
315	FUNC:GEN:MPP:IND_7	Index 7 = Set read mode for MPP data	
316	FUNC:GEN:MPP:DATA?	Read the MPP values U_{MPP} , I_{MPP} and P_{MPP}	

6. Profibus & Profinet

6.1 General

Connection to the field buses Profibus and Profinet are only possible via the interface modules **IF-AB-PBUS** (Profibus) or **IF-AB-PNET** (Profinet, 1 or 2 ports) and thus limited to select series:

- EL 9000 B (HP, 2Q)
- ELR 9000 / ELR 9000 HP / ELR 10000
- PSI 9000 2U - 24U / PSI 10000
- PSE 9000
- PSB 9000 / PSB 10000

On the device side the interface module simplifies the necessary configuration to the absolute necessary. When using Profibus, the user only has to set a slave address (0...125), while Profinet's network settings are usually configured from remote, best by using the Siemens Primary Setup Tool (PST). Other, optional parameters like tags can be defined in the device's setup menu or via command.

This part of the document shall only teach how to use the so-called ModBus register lists (PDF) with your device in order to access indexes and slots via acyclic communication. The list should come along with this document. The interface modules represent the device as a **DP-V1 slave** to the network, capable of cyclic and acyclic data transmission.

6.2 Preparation

For the implementation of a device into a Profibus or Profinet and the enumeration at the master (PLC or similar), a fully configured and wired unit is presumed. The next thing you will usually need is a device description file called GSD (Generic Station Device) for Profibus or a GSDML for Profinet, which is either delivered with the device on the included USB stick or is available as download from the manufacturer's web site or can be obtained upon request.

This GSD/GSDML file enables to build a specific slot configuration for cyclic process data, such as actual values or status. Those slots are also used to access other data objects of the device via acyclic read/write. See more below.

6.3 Slot configuration for Profibus

The slot configuration for users of the interface module **IF-AB-PBUS** is done by loading the GSD/GSE file in the configuration dialogue (with Siemens STEP7: HWCONFIG) and by arranging the slots in a specific order:

Slot	Slot name	Description
1	Device status & acyclic slot 1	Cyclic: Device status (see register list) Acyclic: all registers (indexes) assigned to slot 1
2	Act. voltage & acyclic slot 2	Cyclic: Actual voltage of DC input/output Acyclic: all registers (indexes) assigned to slot 2
3	Act. current & acyclic slot 3	Cyclic: Actual current of DC input/output Acyclic: all registers (indexes) assigned to slot 3
4	Act. power & acyclic slot 4	Cyclic: Actual power of DC input/output Acyclic: all registers (indexes) assigned to slot 4
5	Acyclic slot 5	Acyclic: all registers (indexes) assigned to slot 5
...
12	Acyclic slot 12	Acyclic: all registers (indexes) assigned to slot 12

Example view of the HW CONFIG in Siemens Simatic, with 8 slots:

Steckplatz	DP-Kennung	Bestellnummer / Bezeichnung	E-Adresse	A-Adresse
1	209	Status and acyclic slot 1	256...259	
2	208	Act. voltage & acyclic slot 2	260...261	
3	208	Act. current & acyclic slot 3	262...263	
4	208	Act. power & acyclic slot 4	264...265	
5	208	Acyclic slot 5	266...267	
6	208	Acyclic slot 6	268...269	
7	208	Acyclic slot 7	270...271	
8	208	Acyclic slot 8	272...273	

ModBus & SCPI

The address ranges can of course be re-arranged as required. The slots for acyclic access don't need an output address range, because the input address range already reserves memory space for both directions.

6.4 Slot configuration for Profinet

The GSDML (available on the included USB stick or as download) does not offer automatic slot configuration. When loading the file the correct version for the Profinet interface module in use, 1 port or 2 port, must be selected. After that, the slot placement can be set up like this:

Slot	Slot name	Description
1	Input 2 words	Cyclic: Device status (register 505, see register list) Acyclic: all registers (indexes) assigned to slot 1
2	Input 1 word	Cyclic: Actual voltage of DC input/output (register 507, see register list) Acyclic: all registers (indexes) assigned to slot 2
3	Input 1 word	Cyclic: Actual current of DC input/output (register 508, see register list) Acyclic: all registers (indexes) assigned to slot 3
4	Input 1 word	Cyclic: Actual power of DC input/output (register 509, see register list) Acyclic: all registers (indexes) assigned to slot 4
5	Input 1 word	Acyclic: all registers (indexes) assigned to slot 5
...
12	Input 1 word	Acyclic: all registers (indexes) assigned to slot 12

Example view of the HW CONFIG in Siemens Simatic, with 8 slots:

Steckplatz	Baugruppe	Bestellnummer	E-Adresse	A-Adresse	Diagnoseadresse
0	Default	ABCC-FRT (2-Port)			2043
1	Input 2 word		256...259		
2	Input 1 word		260...261		
3	Input 1 word		262...263		
4	Input 1 word		268...269		
5	Input 1 word		270...271		
6	Input 1 word		272...273		
7	Input 1 word		274...275		
8	Input 1 word		264...265		
9					

The address ranges can of course be re-arranged as required. The slots for acyclic access don't need an output address range, because the input address range already reserves memory space for both directions.

6.5 Cyclic communication via Profibus/Profinet

The Profibus / Profinet slave cyclically transfers process data to certain input addresses of the master, as defined by the user for Profibus or Profinet during slot configuration. Also see sections „6.3. Slot configuration for Profibus“ resp. „6.4. Slot configuration for Profinet“.

Actual values coming from the device have to be translated to real values according to the formula described in section „4.4. Translating set values and actual values“, while any other data are referenced in those so-called register lists which usually should come along with this document. The slot names are partially connected to corresponding registers in the lists. For instance, one slot is named “Actual current”, a name which can be found in the register list at position 508. This is also where the register is enabled for use with Profibus/Profinet use by having a slot/index number assigned.

According to sections 6.3 and 6.4 there are up to 12 slots for acyclic device access, which carry a varying number of indexes (see register lists). By using appropriate blocks/functions (SFB52, SFB53), the user can acyclically access the IDs (slot addresses) and indexes by write and read. The slots for acyclic transfer are only defined to reserve slot addresses and memory space, so it doesn't matter that they are only inputs.



Set values, settable status and most other registers are not transferred cyclically for several reasons. One is the high number of available registers which cannot be covered by only 16 available slots and the max. data size per slot.

6.6 Acyclic communication via Profibus/Profinet

Acyclic communication with the target device is done by using **slots 1-12**, precisely their resulting ID, and **indexes**, which are accessed by system function blocks for read or write. The SFBs to use here are usually SFB52 and SFB53 when using Siemens software. Other PLC control softwares offer similar options.

The SFBs require an ID, an index and a parameter as input. The parameter can be a status or a set value, translated to a hexadecimal value according to „4.4. *Translating set values and actual values*“.

For starters there are example projects (on the included USB stick or as download), one each for Profibus and Profinet, which can be opened with Siemens STEP7 and which shall demonstrate the access to the device with preconfigured data blocks.

The register list for your device series has two extra columns for Profibus/Profinet use only. These define slot and index number for a particular command. The necessary parameter is defined in the register lists respectively, also in „4.4. *Translating set values and actual values*“. Rule of thumb:

- **Registers where no slot/index is given are not supported via Profibus or Profinet**

The general procedure to control a device remotely is like this:

1. **Activate remote control** with the appropriate command (may be denied by the device, see „3.2. *Control locations*“)
2. Control and monitor your device remotely, via cyclic (DP-V0) and/or acyclic (DP-V1) access.
3. Deactivate, i.e. leave remote control

If you just want to record data by reading values from the device, activation of remote control is not necessary. You can send query commands to the device at anytime and the device will respond immediately, if its current situation allows to respond at all. After querying something from the device, the function block will put out the data returned from the device to an output buffer for further processing.

The field bus ensures that the command is transmitted to the device, otherwise it will generate an error. However, it can't verify that the device really accepted the command or already has set the desired value. This can only be verified by reading the value from the device and comparing. Whether a value has been truly transferred to the device's DC input/output can't be determined definitely.

In order to send a command from with a typical Profibus/Profinet software, following applies in general:

1. Select the desired register from the register list and read its assigned slot/index values.
2. Determine the I/Q address which is assigned to the particular slot in HWCONFIG. The use of ID, index, slot and subslot are not just different between Profibus and Profinet, but also between the different PLC systems and softwares. The examples below demonstrate the use with Siemens software.
3. Set ID, index and parameter (set value, status or something else) in decimal or hexadecimal form in the SFB and execute.
4. Process the data returned from the device, if the last message was a query.

6.7 Examples for acyclic access

6.7.1 Activate/deactivate remote control

Remote control is a device state and not the default one. It has to be activated, i.e. requested by the user before the device can be controlled remotely. Depending the settings and on the state the device is currently in when trying to switch to remote control, the device can deny the request.

► How to activate or deactivate remote control of your device via Profibus

1. Use the register list and find the proper command, here: [Register 402 - Remote mode](#).
2. Find the slot and index values for this command in the dedicated columns, here slot 2 and index 1.
3. From the slot configuration read the I/Q address for slot 2 to have the value for parameter "ID", for example 260 (like in the example configs in 6.3 and 6.4) or DW#16#104
4. The value "Index" from the register list is submitted to the parameter INDEX like this:
Profibus: INDEX = Index = 1
Profinet: INDEX = Slot number * 255 + 1 + Index = 510 + 1 + 1 = 512
5. Use a suitable function block in your automation software, for example SFB53.
6. Define the control value to use for this command, as described in the columns "Data" and "Example":
0xFF00 = Activate remote control
0x0000 = Deactivate remote control
7. Configure the function block with ID, INDEX and control value and execute the block. If not somehow inhibited by the device, it should either switch to remote control or back to manual control.

6.7.2 Send a set value

Any command that sets something in the device, no matter if value or status, requires activated remote control status. Also see „6.7.1. Activate/deactivate remote control“ and „3.2. Control locations“.

Before you send a value, you first need to select which one you want to set and you also might need to translate it, because via Profibus/Profinet set values are transferred as per cent of the nominal values. Read sections „4.3. Format of set values and resolution“ and „4.4. Translating set values and actual values“ for more information.

► How to set the DC input/output current value

1. Use the register list and find the proper command, here: [Register 501 - Set current value](#).
2. Find the slot and index values for this command in the dedicated columns, here slot 2 and index 24.
3. From the slot configuration read the I/Q address for slot 2 to have the value for parameter "ID", for example 260 (like in the example configs in 6.3 and 6.4) or DW#16#104
4. The value "Index" from the register list is submitted to the parameter INDEX like this:
Profibus: INDEX = Index = 25
Profinet: INDEX = Slot number * 255 + 1 + Index = 510 + 1 + 24 = 535
5. Use a suitable function block in your automation software, for example SFB53.
6. Define the control value to use for this command, as described in the columns "Data" and "Example". First, read the value range: 0x0000...0xCCCC (decimal: 52428) = Current 0...100%. Second, calculate the set value. For a model with, for example, 170 A nominal current and a desired current of 10 A, this would be $52428/17 = 3084$ --> 0x0C0C.
7. Put the control value 0x0C0C together with ID and INDEX into the function block and execute the block. The device should instantly set 10 A as current limit. This can be verified in the display of the device where it shows the set value of current.

6.7.3 Read something

Reading something from the device is always possible, it means that no remote control is required. Apart from the cyclically transferred data, any other available information can be read via acyclic transfer.

► How to read the actual values of voltage and current

1. Use the register list and find the proper register. The registers of voltage and current are next to each other, the one of voltage is the lower number, thus it will be: Register 507 - Actual voltage
2. Find the slot and index values for this command in the dedicated columns, here slot 2 and index 28
3. From the slot configuration read the I/Q address for slot 2 to have the value for parameter "ID", for example 260 (like in the example configs in 6.3 and 6.4) or DW#16#104.
4. The value "Index" from the register list is submitted to the parameter INDEX like this:
 Profibus: INDEX = Index = 28
 Profinet: INDEX = Slot number * 255 + 1 + Index = 510 + 1 + 28 = 539
5. Read the length of bytes from the column "Data length in bytes" to determine how many bytes to read. In this case there are two registers with length 2 bytes to read, so it's 4 bytes.
6. Use a suitable function block in your automation software, for example SFB52.
7. Configure the function block with ID, INDEX and data length (4 bytes or 2 words of 16 bit, depending in the way the software defines the input).
8. Execute the function block. The data buffer of the block should return the requested data in form of 4 bytes.

The returned 4 bytes will contain the actual voltage value in the first two bytes which is represented as per cent value (for translation see „4.4. Translating set values and actual values“). The actual current value will be in the last two bytes.

By varying the data length to 6 you could also include the actual power value. Alternatively, you can query each actual value separately. To do this, you need to use the corresponding register number to calculate the INDEX and a data length of 2.

6.8 Data interpretation

Data returned from queries, but cyclically transferred data in the first place, have to be interpreted. Let's use an example from a Profibus master simulator where the cyclic data is comfortably displayed. Also see section „4.4. Translating set values and actual values“.

Eingangsdaten			
76543210			
1:	00 00000000 . 0	Slot 1:	Device status (connected to register 505). The value 0x000004C0 says that bits 6, 7 and 10 are set. It means, the device is configured as master (for master-slave), the input/output is on and regulation mode is CC.
2:	00 00000000 . 0	Slot 2:	Actual voltage (connected to register 507). With a 250 V model, for instance, the value 0x263A translates to $250 \text{ V} * 0x263A / 52428 = 46.7 \text{ V}$.
3:	04 00000100 . 4	Slot 3:	Actual current (connected to register 508). With a 510 A model, for instance, the value 0x0C9B translates to $510 \text{ A} * 0xC9B / 52428 = 31.4 \text{ A}$.
4:	C0 11000000 . 192	Slot 4:	Actual power (connected to register 509). For a 5 kW power supply, for instance, the value 0x0925 translates to $5000 \text{ W} * 0x925 / 52428 = 223 \text{ W}$ or 0.22 kW.
5:	26 00100110 . 38	Slot 5:	not used for cyclic data
6:	3A 00111010 . 58	Slot 6:	not used for cyclic data
7:	0C 00001100 . 12	Slot 7:	not used for cyclic data
8:	9B 10011011 . 155	Slot 8:	not used for cyclic data
9:	09 00001001 . 9		
10:	25 00100101 % 37		
11:	00 00000000 . 0		
12:	00 00000000 . 0		
13:	00 00000000 . 0		
14:	00 00000000 . 0		
15:	00 00000000 . 0		
16:	00 00000000 . 0		
17:	00 00000000 . 0		
18:	00 00000000 . 0		



For users with a PSB 9000 or PSB 10000 device: like represented on the device's display, actual values of current or power can be negative, depending on the operation mode. The register definition does not support negative values, but the "Device status" register 505 indicates the operation mode, i. e. source or sink mode, via bit 12. The bit can be used to invert the actual values of current and /or power for sink mode and later processing.

7. CANopen

The available communication objects (ADIs) in an Electronic Data Sheet file (EDS/XDD), which is delivered with your device on a USB stick or available as download from the manufacturer's website. This EDS can be integrated in CANopen related software. The EDS indexes are not separately explained, because their definition and use is identical to herein described ModBus protocol and the related, external register list files (see „4.7. About the register lists“). Examples from the ModBus part of this document can be used and applied for CANopen as well, but would be reduced to the core data, because CANopen user are not confronted with checksums and function codes as with ModBus.



The CANopen module IF-AB-CANO does not feature an internal termination resistor. Thus the bus termination has to be applied by the user according to the CAN bus requirements.

7.1 Preparation

For the communication with the device via CANopen interface **IF-AB-CANO**, a few things are required:

1. A suitable CAN cable, preferably with switchable termination resistor, which has to be activated always if the device is at the end of the bus, like when directly connecting the PC to a single ELR 9000 unit.
2. EDS/XDD (included with the device on USB stick).
3. CANopen software for the PC (not included, any available software for CANopen should suffice).
4. Documentation about how to use the supported indexes. See sections 1. - 4., 7.2 and 9., as well as the included register list(s).

7.2 User objects (indexes)

The message format used via CANopen communication is related to ModBus. A specific index is connected to a specific ModBus register. The CANopen standard defines that user objects are enumerated from index 2001. With ModBus, the registers are counted from 0. It means, that index 2001 corresponds to register 0 or index 21F5 corresponds to register 500 etc.

The EDS/XDD contains less indexes than the device supports ModBus registers. But the available indexes still cover the most functions of the device to be used via remote control. User can edit the EDS/XDD anytime and add further indexes.

Along with this document there usually are so-called register lists for primary ModBus use, but these can also be used for CANopen, as they also define data type and value range of the indexes. Examples in other sections of this documents can be applied for CANopen as well.

7.2.1 Translation ADI -> register

The translation of an CANopen index, as listed in the EDS file, to a register address is quite easy due to the fixed offset 0x2001. For example, if you pick the index "207A Nominal voltage" from the EDS, it translates like this:

Index number - Offset = register address --> 0x207A - 0x2001 = 0x79 (hex) = 121 (dez). According to the register list for an ELR 9000 device, this represents the nominal device voltage as a FLOAT value. Because CANopen does not support the data type FLOAT, the EDS uses REAL32 here. The user just has to translate the 32 bit value according to IEEE 754 specification.

7.3 Specific examples

7.3.1.1 Switching to remote control

As described in „4.8.9.5. Switch to remote control or back to manual control“, it's required to switch the device to remote control before you can control it. In order to do this, you first need to find the proper command, i.e. register in the register list resp. the dedicated index in the EDS. In this case, it's register 402 resp. index 0x2193. The register list defines that the value 0xFF00 has to be sent to switch to remote or value 0x0000 to leave remote control.

7.3.1.2 Setting a set value

After remote control has been accepted by the device, you are allowed to send set values. Those values usually represent a per cent value. From the definition in the register list, 100% of a value translated to the hexadecimal value 0xCCCC and 0% to 0x0000. It means, there are 52429 possible values between 0% and 100%. It has to be pointed out here, that this is not the true resolution values like voltage or current actually achieve at the DC input/output. The effective resolution of output/input values is 26214 steps. An example for set value translation is in „4.8.9.1. Writing a set value“.

7.4 CANopen to ModBus differences

7.4.1 When using the arbitrary generator

Due to CANopen only being able to transport a maximum of 4 effective user data bytes per message, the 8 values of data defining a sequence point of the arbitrary generator cannot be transferred at once, but in 8 separate messages. The device checks every single value for plausibility upon reception, but once all sequence points are set without any error **it requires to send an additional submit command (index 235F)**. This will transfer all sequence point data and load the function into the function generator and enable start/stop action. Without sending that command the function generator would either run with all data being zero or using old data.

The steps to perform, as described in section 4.10.6.1, are the same for CANopen, except for the additional step 3.1:

Step 1:

Select, whether to apply the function to the voltage U (index 2354) or the current I (index 2355). Before you haven't made this selection, the device can not accept sequence point data, because the data is run through a plausibility check against the device's nominal values.

Step 2:

Define start sequence point (index 235C), end sequence point (index 235D) and number of cycles of that sequence point block to repeat (index 861).

Step 3:

Load data for all required sequence points (x out of 99, indexes 2385 - 29A5, 8 values per sequence point in sub indexes).

Step 3.1:

Submit the data by writing 0xFF00 to index 235F (register 862, undocumented for ModBus, because not required there)

Step 4:

Set global voltage limit (index 21F5), if the function is applied to the current. Else set global current limit (index 21F6), if the function is applied to voltage. Set global power limit (index 21F7) for both modes.

Step 5:

Control the function generator with start/stop (index 2353).

Step 6:

When finished, leave the function generator by deselecting your former selection of either U (index 2354) or I (index 2355) again by writing 0x0000.

7.5 Error codes

Following error codes, as part of the CANopen standard, are supported by the CANopen interface module:

Code	Description
0x06020000	Object does not exist in the object dictionary (ModBus register list)
0x06040043	Command not supported
0x06099911	Sub-Index does not exist
0x06010002	Attempt to write a read only object
0x06010002	Attempt to read a write only object
0x06070012	Too much data
0x06070013	Not enough data
0x06090030	Value range of parameter exceeded
0x08000022	Data could not be transferred or stored to the application because of the present device state
0x05040005	Out of memory
0x08000000	General error

8. CAN

This section is solely dedicated to the communication with a device via the CAN interface IF-AB-CAN. Configuration of the interface itself is done on the control panel (HMI) of the device. Also see the device manual.

8.1 Preparation

What is required for communication with the device via CAN module **IF-AB-CAN**?

1. A suitable CAN cable. It's not required to have one with integrated bus termination switch and resistor, because the interface module has an electronically switched resistor for bus termination. In case the cable also has one, it's important to take care to activate only one of both, else there can be bus errors.
2. When using Vector™ or similar software which can make use of so-called database files (DBC), a dedicated DBC for the particular device model. If not available, it can be requested from the manufacturer or created by the user, for example by modifying a similar one.
3. CAN software for the PC (not included, any available software for CAN should suffice).
4. Documentation about how to use the supported CAN objects. See below and sections 1. - 4., as well as the included register list(s).

8.2 Introduction

The data format is derived from the previously in this document described ModBus RTU. In relation to a database file (DBC) a **mux value** (Vector terminology) represents a specific **ModBus register** or object/command. Objects in the database are thus selected by the muxer and when programming the CAN message buffer directly (CAPL), the first two bytes of data in a CAN message define the register (object, command) to access. The selection between writing and reading objects is done by the CAN ID.

Each device will be assigned at least three CAN IDs, which are defined via the so-called Base ID in the device's CAN settings. The Base ID is used write to objects (message type: **Send_Object**), while querying objects (message type: **Query_Object**) is done with Base ID+1 and responses (message type: **Read_Object**) coming from the device use Base ID+2. Responses from the device are expected after a query, but can also be received unexpectedly in case of communication or access error. When adjusting the Base ID of a device, the other related IDs will shift automatically.

There is another adjustable ID, the Broadcast ID. It's separate from all others and can be used to address multiple devices at once by one command when using the same broadcast ID on these device. This ID is for write access (Send_Object) only. Queries to multiple devices at once with one message are not possible.

Apart from the Base ID and Broadcast ID for acyclic access, some series support further adjustable IDs for cyclic status data which is sent permanently by the device once activated and after the CAN connection has been established. Refer to the device manual for setup, particularly the section for the communication settings, and also further below.

8.3 Message formats



Below explanations are, besides the selection of IDs to switch between write and read actions, also related to the ModBus functions, as listed in the register lists in columns 2-6.

8.3.1 Normal sending (writing)

Writing to the device always used the base ID or the broadcast ID. It requires to define the first register/object to write to in the CAN data, as well as the number of registers to write and a specific number of parameter bytes which can represent different data types.

Access: Base ID, broadcast ID

Connected ModBus functions: Write Single Coil (WSC), Write Single Register (WSR)

Bytes 0+1	Byte 2	Bytes 3+4
Register	Nr. of regs to write	Data
0...65534	Always 1	Value (16 bit)

ModBus & SCPI

Access: Base ID, broadcast ID

Connected ModBus function: Write Multiple Registers (WMR)

Bytes 0+1	Byte 2	Byte 3	Bytes 4-7
Start reg.	Nr. of regs to write	Marker	Data bytes
0...65534	2...123	0xFF, 0xFE...	Four bytes or two 16 bit values or one 32 bit value

Start register: always the register number from the register list, i. e. start register, even for WMR.

Nr. of regs to write: refer to the register list. An object defined with 40 bytes occupies 20 registers, so when writing to such an object the value here would have to be 20.

Marker: is used to distinguish single messages from split messages and to detect the correct sequence of data. For example, a string like the user text can be up to 40 characters long and when writing it has to be split across multiple messages. Every message can transport 4 characters of the string. The marker always starts with 0xFF and is counted down (0xFF, 0xFE...) with every next split message belonging to a transmission. The marker is required, because on CAN bus it's not guaranteed that messages are received in the same order they were sent.

Data bytes: the number of bytes in this type of message is always 4, no matter if all bytes are filled with information from the actual data to transmit or are 0. An example: an user text with a length of 15 characters would require to send at least 4 messages. The object for the user text is defined to have 20 registers, means 10 messages. Since you would write to less registers than defined you would only have to reduce the number of **Nr. of regs to write**. In this example it would be 8, resulting in 4 messages containing 16 bytes (15 bytes of string + termination character).

8.3.2 Cyclic sending (writing)

Cyclic sending (or writing) is intended for compact and time efficient transmission of often used set values and status in form of a **block of data**. It uses separate CAN IDs. The user defines the interval of cyclic send via timing in the CAN software, though we recommend to stick to timing recommendations as described in section 3.3.3.



It's strongly recommended to send the block "Control" after the other data blocks, especially when remote control has not yet been activated. It means, you would best write the set values first to "Base ID Send + 1", then further ones to "Base ID Send + 2" (only with PSB 9000 and PSB 10000 series devices) and as last step write the status to "Base ID Send". This will submit all data internally and since block "Control" would contain "remote control = on", the set values in the other blocks would be accepted without error.

In order to use this feature, the user only has to define the separately adjustable "Base ID Cyclic Send" and can then send two different messages with following format:

Access: Base ID Cyclic Send ("Control")

Bytes 0-1
Control word

Control word definition:

Bit	Name	Related register	Meaning
0	Remote control	402	Activates remote control of the device with 1 or deactivates it with 0
1	Eingang/Ausgang	405	Switches the DC input/output of the device on with 1 or off with 0
2	UIP / UIR	409	Activates resistance control mode (UIR, where featured) with 1, while with 0 mode UIP will be active
3	Spannungsregler	422	Only available with electronic loads: switches the speed of the internal voltage controller between „fast“ (1) „slow/normal“ (0)
4	Alarme	411	A 1 acknowledges all currently acknowledgeable alarms



This control word requires special attention, as the 5 bits can trigger several actions at once which don't have a certain priority of processing. It means, if you would try to activate remote control together with switching on the DC input/output (bits 0 and 1 both TRUE), you may receive a settings conflict error, because the device would possibly process bit 1 before bit 0.

ModBus & SCPI

Access: Base ID Cyclic Send + 1 ("Set values 1")

Bytes 0-1	Bytes 2-3	Bytes 4-5	Bytes 6-7
Register 500	Register 501	Register 502	Register 503
Set value of voltage	Set value of current	Set value of power	Set value of resistance



With series PSB 9000 and PSB 10000, these four set values belong to the "source mode", listed as "Set values [PS]" on the HMI under "Base ID Cyclic Send".

Access: Base ID Cyclic Send + 2 ("Set values 2") (PSB 9000 series only)

Bytes 0-1	Bytes 2-3	Bytes 4-5
Register 499	Register 498	Register 504
Set value of current (EL)	Set value of power (EL)	Set value of resistance (EL)



With series PSB 9000 and PSB 10000, these three set values belong to the "sink mode", listed as "Set values [EL]" on the HMI under "Base ID Cyclic Send".

8.3.3 Querying

Querying an object is the first part of a read action. It's always done via Base ID + 1. The device should then respond via Base ID + 2 (Read_Object) and with the expected data. Only after reading the response, the read action is finished. In order to query an object via the Query ID (Base ID + 1) it's sufficient to send the start register number. The device will respond with the correct length of data, but in different. See below at 8.3.4.

Access: Base ID + 1

Connected ModBus functions: Read Coils (RC), Read Holding Registers (RHR)

Bytes 0+1
Start reg.
0...65534

8.3.4 Normal reading

Data coming from the device can be a single message (expected data or error) or can be split messages forming a response. The information is either in a buffer or, when using Vector software, automatically sorted into signals. The data of split messages has to be combined again according to the marker. Even the Vector database cannot do this automatically. But there are only a few objects like the user text which require this treatment and these are usually not accessed very often.

Access: Base ID + 2

Response with one message (number of queried registers 1-3):

Bytes 0+1	Bytes 2-7
Register	Data
0...65534	1-3 registers

Response with multiple messages (number of queried registers >3):

Bytes 0+1	Byte 2	Bytes 3-7
Register	Marker	Data
0...65534	0xFF, 0xFE...	5 bytes

Response as error message:

Bytes 0+1	Byte 2
65535	Error code

The error codes used here are the same as with ModBus. See „4.8.8. Communication errors“.

ModBus & SCPI

8.3.5 Cyclic reading

The cyclic read feature is an extended function where the device can automatically send specific objects to specific IDs and in a specific interval. Cyclic read messages differ from those of normal read actions.

In order to activate and use cyclic read, the user has to

1. set the extra Base ID Cyclic Read on the device (HMI, CAN settings).
2. define which of the 5 available objects for cyclic read are going to be used and activate them by setting the interval time to a value other than zero.
3. process the received data separately and differently, because the data format is different here (see below).

The interval times for the cyclic objects can be set separately and arbitrarily. In case they match or overlap, the device will send the corresponding messages subsequently and as fast as possible.



The minimum interval is 20 ms. When using a very low CAN bus speed, for example 10-50 kbps, CAN bus errors may occur when multiple cyclic read items are active, because of too much traffic.

Once cyclic read is activated by setting the interval time of at least one item and as soon as a CAN connection is established, the device will start to automatically and permanently send messages to the defined IDs. The cyclic read feature can be turned off or on anytime using the CAN settings on the HMI or the corresponding commands sent as acyclic CAN message.

There are up to 6 CAN IDs reserved for cyclic read. Starting at the adjustable "Base ID Cyclic Read" (see HMI of the device) the data in the messages is defined as follows:

Access: Base ID Cyclic Read ("Status")

Bytes 0-3
Device status (32 Bit)

Bit layout of the device status value:

Bit	Name	Meaning	Bit	Name	Meaning
31	Remote control	1 = on	15	-	
30	Input / output	1 = on (req., register 405)	14	Alarm OVD	1 = alarm active
29	Volt. reg. speed	1 = fast (register 422)	13	Alarm OVP	1 = alarm active
28	Operation mode	0 = UIR, 1 = UIP	12	Alarm PF	1 = alarm active
27	Alarms	1 = at least 1 alarm active	11		
26	Alarm MSS	1 = alarm active	10		
25	Alarm OCD	1 = alarm active	9	REM-SB	1 = on (register 505, bit 30)
24	Alarm OCP	1 = alarm active	8	Alarm UCD	1 = alarm active
23	Interface in access	register 505, bits 4-0	7	Alarm UVD	1 = alarm active
22			6	Remote sensing	1 = external, 0 = internal
21			5	Function gen.	1 = FG active
20			4	MS type	1 = master, 0 = slave
19			3	Input / output	1 = on (register 505, bit 7)
18	Alarm OPD	1 = alarm active	2	Reg. mode	register 505, bits 10-9
17	Alarm OPP	1 = alarm active	1		
16	Alarm OT	1 = alarm active	0	PSB mode	0 = source, 1 = sink

Access: Base ID Cyclic Read + 1 ("Actual values")

Bytes 0-1	Bytes 2-3	Bytes 4-5
Register 507	Register 508	Register 509
Actual voltage	Actual current	Actual power



PSB 9000 / PSB 10000 only: these actual values are unsigned. In order to interpret them as negative values during sink mode operation, bit 0 of block "Status" has to be used.

ModBus & SCPI

Access: Base ID Cyclic Read + 2 ("Set values 1")

Bytes 0-1	Bytes 2-3	Bytes 4-5	Bytes 6-7
Register 500	Register 501	Register 502	Register 503
Set value of voltage	Set value of current	Set value of power	Set value of resistance



With series PSB 9000 and PSB 10000, these four set values belong to source mode operation, listed as "Set values [PS]" on the HMI under "Base ID Cyclic Read".

Access: Base ID Cyclic Read + 3 ("Limits 1" or "Limits 1 [PS]")

Bytes 0-1	Bytes 2-3	Bytes 4-5	Bytes 6-7
Register 9002	Register 9003	Register 9000	Register 9001
I-max	I-min	U-max	U-min



With series PSB 9000 and PSB 10000, these adjustment limits only belong to source mode operation, listed as "Limits 1 [PS]" on the HMI under "Base ID Cyclic Read".

Access: Base ID Cyclic Read + 4 ("Limits 2" or "Limits 2 [PS]")

Bytes 0-1	Bytes 2-3
Register 9004	Register 9006
P-max	R-max

Access: Base ID Cyclic Read + 5 ("Set values [EL]") (PSB 9000 and PSB 10000 series only)

Bytes 0-1	Bytes 2-3	Bytes 4-5
Register 499	Register 498	Register 504
Set value of current (EL)	Set value of power (EL)	Set value of resistance (EL)

Access: Base ID Cyclic Read + 6 ("Limits [EL]") (PSB 9000 and PSB 10000 series only)

Bytes 0-1	Bytes 2-3	Bytes 4-5	Bytes 6-7
Register 9008	Register 9009	Register 9005	Register 9007
I-max	I-min	P-max	R-max



With series PSB 9000 and PSB 10000, these adjustment limits only belong to sink mode operation, listed as "Limits [EL]" on the HMI under "Base ID Cyclic Read".

8.3.6 Message examples

8.3.6.1 Switching to remote control

As described in „4.8.9.5. Switch to remote control or back to manual control“, it's required to switch the device to remote control before you can control it. In order to do this, you first need to find the proper command, i.e. register in the register list resp. the dedicated index in the EDS. In this case, it's register 402 (hex: 0x192). The register list defines that the value 0xFF00 has to be sent to switch to remote or value 0x0000 to leave remote control.

Assuming the device has been set to Base ID 0x20, the data to be sent according to 8.3.1 would be:

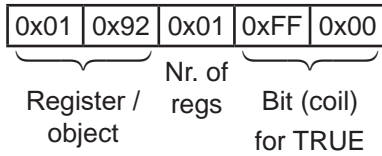

The device should switch to remote control immediately after reception, if not inhibited somehow. The status of remote control can be read from the display or by reading another object.

8.3.6.2 Write and read back a set value

After remote control has been accepted by the device, you are allowed to send set values. Those values usually represent a per cent value. From the definition in the register list, the hexadecimal value 0xCCCC translates to 100% and 0x0000 to 0%. It means, there are 52428 possible values between 0% and 100%. It has to be pointed out here, that this is not the resolution a device value like voltage or current can have at the DC input/output. The effective resolution of output/input values is 26214 steps. An example for set value translation is in „4.8.9.1. Writing a set value“.

Power supply model PSI 9080-170 3U has a nominal current of 170 A. If you wanted to set it to 35 A, the set value according to the formula in 4.4 calculates as: $35 \text{ A} * 52428 / 170 \text{ A} = 10794 = 0x2A2A$. The current is set with register 501. Assuming the device would have been set to **Base ID 0x88** the data to be sent to this ID, according to 8.3.1, would be:

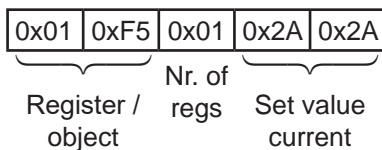

Soon after the device received and accepted the value, it's set and could be read from the display or also by reading it back using the same object. With the same base ID, the query message would be



and would have to be sent to the query ID of the device, here **0x89**. Short after this, the device should respond the requested value on the read **ID 0x8A**:

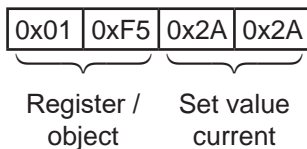

In case the values has not been accepted when sending it, for example because the adjustment limit for current (I-max) has been set to 30 A, the device may have responded with an error message (see 8.3.4) instead of the expected one:

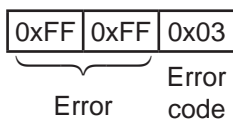

The ModBus error code 0x3 tells "wrong data". In this case, the set value was too high.

9. EtherCAT

9.1 Preamble

Those device series supporting the Anybus interface modules (see „2.2. Anybus module support“) will also support the new EtherCAT module IF-AB-ECT by installing a firmware update. The update will be available from August 2016 as download or upon request.

Per definition, the EtherCAT data communication is based on CANopen, thus also called "CANopen over Ethernet (CoE)". All documentation for EtherCAT and CANopen is provided by the Beckhoff company resp. the CiA organisation. Below anything related to software refers to Beckhoff's TwinCAT.

9.2 Integrating your device in TwinCAT

Newer devices are shipped with an USB stick that holds an ESI file, an EtherCAT device description in XML format. Alternatively, that file can be obtained upon request when updating an older device for EtherCAT support. The file is simply put into a dedicated folder in the TwinCAT installation. Default path:

```
c:\TwinCAT\
```

After installing that file and restarting the TwinCAT IDE, our EtherCAT slaves can be integrated into the setup with the **"Insert EtherCAT Device"** dialog and by selecting the device name "IF-AB-ECT (for standard" or "IF-AB-ECT (for bidirectional)" if you have bidirectional power supply from PSB 9000 or PSB 10000 series.

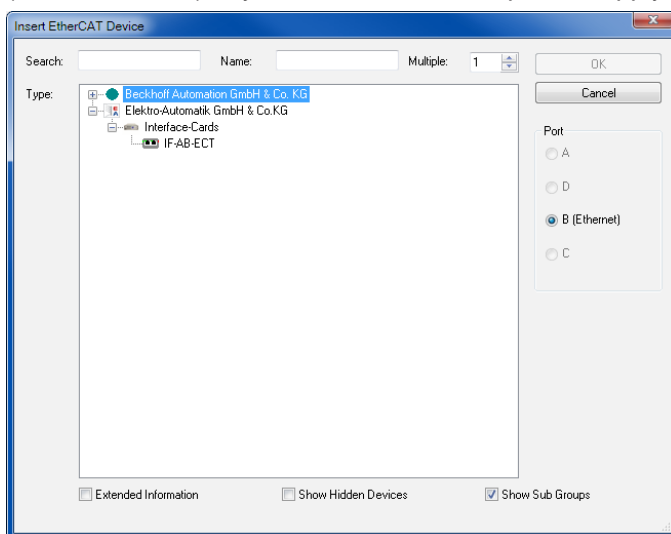

Further slaves can be added with the same method.

9.3 Data objects

The devices internally use ModBus protocol and for CANopen over Ethernet communication in both directions the messages are translated. This is why the reference for all cyclic data (PDOs) and acyclic data (SDOs) are those ModBus register lists. They are included with the device on USB stick (or are available as download) as part of the programming documentation. The acyclic objects are downloaded from the device when accessing an online EtherCAT slave in tab "CoE" in TwinCAT. Offline objects in form of an EDS file are not available.

Together with the PDOs defined in the ESI file the complete list of indexes then becomes accessible and enable the user to completely control the device.

There is a connection between the CoE indexes and the ModBus register numbers in the lists. You can translate both back and forth.

• Translating ModBus register ► CANopen index

ModBus register number in decimal + 8193 ► convert to hexadecimal = index

Example: you want to set the device into remote control mode and want to find the corresponding CoE index. In the register list you have register number 402 for this task. Calculation: $402 + 8193 = 8595$ ► converted to hexadecimal it's 0x2193, hence index 2193.

• Translating CANopen index ► ModBus register

CANopen index in hexadecimal - 0x2001 ► convert to decimal = register

Example: you need know the meaning of the bits in the PDO "Status". Find the corresponding CoE index in the index list. Here it's 21FA. Calculation: $0x21FA - 0x2001 = 0x1F9$ ► converted to decimal it's 505. In the register list you will find register number 505 and the layout of the 32 bit value.

ModBus & SCPI

9.3.1 PDO object

The device description file defines for our EtherCAT slaves the same set of object in the one PDO:

Name	EtherCAT data type	Length in bytes	ModBus register	Short description
Status	UDINT	4	505	Device status
Voltage Monitor	UINT	2	507	Actual voltage on DC input/output (in per cent)
Current Monitor	UINT	2	508	Actual current on DC input/output (in per cent)
Voltage select	UINT	2	500	Set value of voltage (in per cent)
Current select	UINT	2	501	Set value of current (in per cent)
Power select	UINT	2	502	Set value of power (in per cent)
Resistance select	UINT	2	503	Set value of resistance (in per cent)

Bidirectional devices from series PSB 9000 and PSB 10000 have more set values, so there the PDO is extended by:

Name	EtherCAT data type	Length in bytes	ModBus register	Short description
Current select EL	UINT	2	499	Set value of current (in per cent) for sink mode
Power select EL	UINT	2	498	Set value of power (in per cent) for sink mode
Resistance select EL	UINT	2	504	Set value of resistance (in per cent) for sink mode

9.3.2 SDOs

The acyclic data objects for use in the EtherCAT system are defined in your device and can be downloaded from it. It requires the device to be online with the EtherCAT system. There is no separate documentation for the downloadable data objects. Like with CANopen (see „7. CANopen“), the register lists which are part of the programming documentation are the reference for the SDOs to explain data content and function, as well the section of this document dealing with the ModBus protocol and its examples.

9.3.3 Use of the data objects

Please refer to „7.2. User objects (indexes)“.

A. Appendix

A1. Device classes

For distinction of different device series and especially of variant within one series a device class number is assigned to every device. It can be read from the device (register 0 or SYSTEM:DEVICE:CLASS?) and be used to easily distinguish a power supply from an electronic load when scanning a network for units of our make.

Class	Assigned to series
20	ELR 9000
21	PSI 9000 2U/3U (models from 2014)
23	PS 5000
24	PS 2000 B Triple
28	PS 9000 2U/3U (models from 2014)
29	PSI 5000
30	PS 9000 1U
32	ELR 9000 TFT
33	PSI 9000 2U/3U TFT
34	ELR 9000 TFT 3W
35	PSI 9000 2U/3U TFT 3W
38	PS 9000 2U/3U 3W
39	EL 9000 B
41	ELR 5000
42	PSI 9000 DT
43	PSE 9000 3U
44	EL 9000 DT
45	PSI 9000 Slave
46	EL 9000 B Slave
47 / 50	PSI 9000 T
48 / 51	EL 9000 T
49 / 56	PS 9000 T
52	PSI 9000 3U / EL 9000 B 2Q (front USB only)
53	EL 9000 B 2Q
54	EL 9000 B 3W
55	EL 3000 B
58	PSB 9000
59	ELR 9000 HP
60	ELR 9000 HP 3W
61	PSB 9000 Slave
62	PSB 9000 Slave (front USB only)
63	PSB 9000 3U 3W
64	PSBE 9000
65	ELR 9000 HP Slave
66	PSB 10000

Legend:

TFT = Model/series with TFT touch panel (older series had LCD touch panel)

3W = Model/series with option 3W installed

1U / 2U / 3U = Enclosure type is 19" with 1U or 2U or 3U height

T = Enclosure type: Tower

DT = Enclosure type: Desktop

R = Enclosure type: wall mount

2Q = Slave unit for two-quadrants operation

Contact Us

sales@inteproate.com

Americas

Intepro Systems America, LP
14662-E Franklin Ave
Tustin, CA 92780
Tel: 1 714 953 2686
sales@inteproate.com
www.inteproate.com

service@inteproate.com

Europe & Africa

Intepro UK Ltd.
9 Lakeside Business Park
Swan Lane, Sandhurst Berkshire
GU47 9DN / UK
Tel: 44 012 5287 5600

www.inteproate.com

Asia & Oceania

Intepro Power Electronics
(Shenzhen) Co., Ltd
No. 828, Block 7,
Fourth Industrial Area
Nanyou, Nashan District
Shenzhen, China 518052
Tel: 0086 755 86500020