

Dual Load - E2010 Series

- TWO FULLY ISOLATED ELECTRONIC LOADS, EACH 150 WATTS
- OPERATES STANDALONE OR PARALLEL FOR 300 WATTS
- CONSTANT CURRENT, POWER, AND RESISTANCE MODES
- HIGH SPEED OPERATION, LESS THAN 25USEC LOOP RESPONSE

The E2010 Dual load module is ideal for providing modular load capability in any automatic test system. Each load is fully featured and provides 150Watts of isolated load sink capability, a total of 300Watts per module. This is available as an RE2010 module which is for a 6U high rack or as a 1U standalone Ethernet Instrument.

Multiple modules can be configured in parallel to facilitate higher power outputs. Each E2010 rack can accommodate up to 10 load modules (2.7Kwatts per rack) and multiple racks can be configured in a system.

This makes the Intepro E2010 load system one of the most cost effective and modular load facilities available on the market today. Each load is fully programmable with twelve (12) bit resolution. In addition each load has two ranges to improve overall program accuracy. Each load can operate in constant current and constant resistance mode. The load may also be modulated (pulsed) by an external signal source using the on board pulse relays. Each load also has built in relays to facilitate easy O.V.P. (backdrive) testing in a power supply test system. Each load is also electronically protected from Over Power, Over Current and Over Temperature. This is a key feature to ensure reliable operation in the harsh environments of power supply testing.

The module also has a jumper selectable loop response time setting. The load can be operated at high speed in normal functional test systems. However, the loop response can be slowed down in applications such as Burnin where there may be very significant



Dual Load

lead lengths in the fixture wiring to the units. The inductance associated with long wire lengths could cause the load to oscillate if the loop response was too fast.

The module is fully supported by POWERSTAR software platforms supplied by Intepro.

The module is designed for simple plug in insertion into an E2010 backplane system (low cost).

User connection to the module is via Positronic 7W2 female connectors. This facilitates high power and signal connection in one easy to remove connector.

The E2010 Dual load is ideal for high specification, medium power, load requirements in an ATE system.

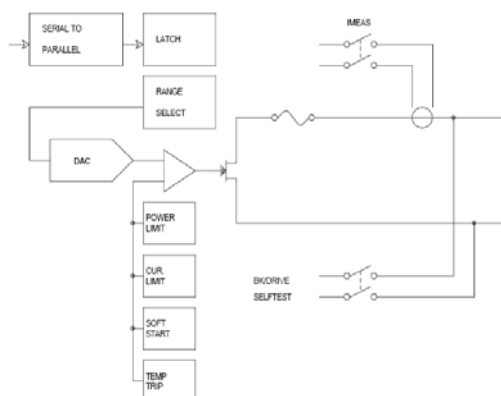

Technical Specifications

	Range	Resolution	Accuracy	
Constant Current	Range 1	0A to 7.5A	2mA	+/- (0.25 % setting + resolution + 3mA)
	Range 2	0A to 30A	8mA	+/- (0.25 % setting + resolution + 3mA)
Constant Resistance	Range 1	0.0667R to 0.667R	0.004*Vin	+/- (0.25% setting 3+ (0.004*vin +3mA))
	Range 2	0.667R to 2730R	0.0004*Vin	+/- (0.25% setting + (0.0004*vin +3mA))
Power Rating	150 Watts max (per load)			
Response time	20uSec (min) - 200uSec (max)		(jumper selectable)	
Operating temp	0degC to 55DegC			
Measure accuracy	0.25 % of actual current+3mA			
Input voltage range	0.5V to 100V DC			
Humidity	10% to 85% Relative			
ORDERING INFORMATION				
Part Number:	721-0005 (for a 6U Rack) 722-0005 (for a 1U Assembly)			
Description	30A/100V/150-Watt Dual Load			

INTEPRO
SYSTEMS

www.InteproATE.com

INTEPRO SYSTEMS EU/IRELAND

1530 S. Lyon Street
Santa Ana, CA 92705
USA
Tel: +1.714.679.9749
Fax: +1.714.953.3150

EU/IRELAND

Intepro Systems
Lonsdale Road,
National Technology Park
Limerick / Ireland
Tel: +353.61.33.22.33
Fax: +353.61.33.25.84

UNITED KINGDOM

Intepro Systems
1 Lakeside Business Park
Swan Lane, Sandhurst
Berkshire GU47 9DN / UK
Tel/Fax: +44.1252.875.600

CHINA

No.2405, Block D
Shahe Century Holiday Plaza
Nanshan District
Shenzhen, China 518053
Tel: +86 755 86398564
Fax: +86 755 86398567