

INTEPRO SYSTEMS

www.InteproATE.com

E2010 Series



THE POWER TEST EXPERTS

www.InteproATE.com

DIGITAL CONTROLLER - E2010 Series

- ETHERNET BASED CONTROLLER
- CONTROLS ALL TEST SYSTEM RESOURCES OVER A SINGLE BUS
- INTEGRATED WEB SERVER
- REMOTE SYSTEM CONTROL

Designed by Intepro engineers to consolidate all system control to a single Ethernet interface bus. It can control up to 128 loads over the internal CAN bus, as well as all other GPIB OEM Instruments and Intepro modules in the system.

FEATURES

- Ethernet to GPIB control
- Web based System Configuration
- Web based System Interactive Control
- Fully Compatible with all previous Controllers
- Supports DHCP, Static IP and Auto IP
- Ethernet based firmware upgrades
- Multi threaded HTTP UDP and TELNET
- Optional 32Bit Digital IO
- Optional RS232/485, I2C and SPI

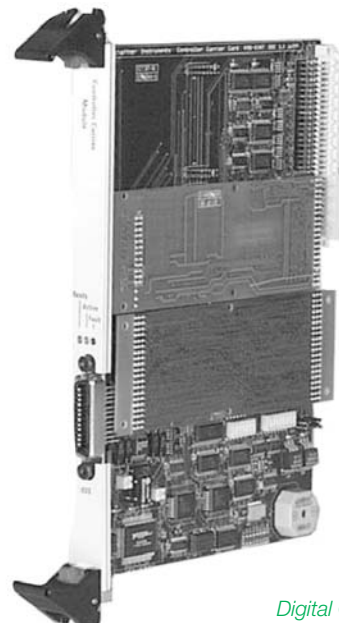

Digital Controller

The Controller consists of a motherboard and up to two daughter cards. One daughter card contains the high performance risc processor, the other daughter card slot is for the Digital IO, RS232/485, I2C and SPI Interface Busses option.

Web based Interactive Control

The Web based Interactive control allows the user to interactively control all the Test Systems Hardware via the embedded web server. There is a simple send/receive utility or routines can be setup.

Web based System Configuration

The Web based System Configuration allows the user to setup the controller and Test System hardware via the Embedded Web Server.

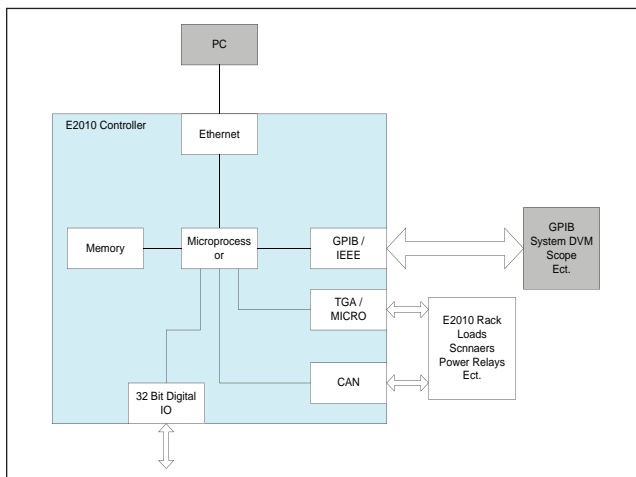

Digital Controller Block Diagram

Technical Specifications

Digital Controller Carrier Card

Input Voltages:	110/230Vac
Operation Temperature:	5°C to 40°C
Storage Temperature:	5°C to 70°C
Humidity:	20% to 80% RH (non condensing)
Dimensions:	261mm height x 20mm width
Communications Interface:	Ethernet
Ethernet Speed:	10/100base T
Processor Speed:	66MHz

Safety

Meets the safety requirements laid down in the following standard: IEC 1010

Options

RS232/485, I2C and SPI	This optional feature will require the fitting of an additional M-Module card
TX/RX Latches:	Optional 32 Bit Digital IO

Ordering Information

Part Number	721-0000 (for a 6U Rack) 722-0000 (for a 1U Assembly)
Description	E2010 Digital Controller

INTEPRO
SYSTEMS

www.InteproATE.com

INTEPRO SYSTEMS EU/IRELAND

1530 S. Lyon Street
Santa Ana, CA 92705
USA
Tel: +1.714.679.9749
Fax: +1.714.953.3150

EU/IRELAND

Intepro Systems
Lonsdale Road,
National Technology Park
Limerick / Ireland
Tel: +353.61.33.22.33
Fax: +353.61.33.25.84

UNITED KINGDOM

Intepro Systems
1 Lakeside Business Park
Swan Lane, Sandhurst
Berkshire GU47 9DN / UK
Tel/Fax: +44.1252.875.600

CHINA

No.2405, Block D
Shahe Century Holiday Plaza
Nanshan District
Shenzhen, China 518053
Tel: +86 755 86398564
Fax: +86 755 86398567

Measurement Module - E2010 Series

- FULFILLS ALL BASIC PSU MEASUREMENT REQUIREMENTS IN ONE MODULE
- COST EFFICIENT TEST AT HIGH SPEED WITH PARALLEL MEASUREMENT
- MULTI PURPOSE, MULTI CHANNEL INSTRUMENT
- AC/DC VOLTAGE, FREQUENCY, RIPPLE/NOISE AND INTERVAL TIMING MEASUREMENT

This module was specially designed to provide a high-speed, complete test solution for PSU systems. This high-performance component of the E2010 system combined with PowerStar 5 software, meets all industry standard power supply measurement requirements.

FEATURES

- DC and AC Voltage Measurement
- RMS and Peak to Peak Ripple Noise Measurement
- Frequency Measurement
- Programmable Input Thresholds on Timing Channels
- 10 Input Scanning Matrix
- GPIB Interface

Key to the Measurement Module's operation are the two powerful DSPs located on the Digital Board. Controlled by PowerStar 5 they provide the necessary processing power for today's high speed production test environment.

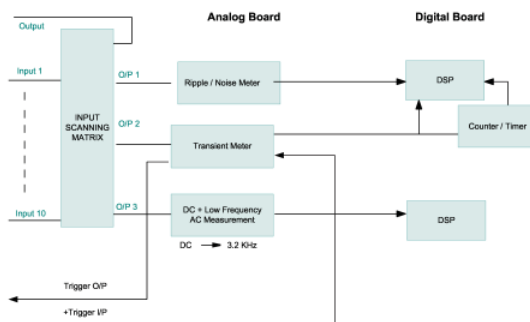

Measurement Module Block Diagram



Measurement Module

The Measurement Module is made up of the following functional blocks:

Ripple Noise

The ripple/noise meter measures RMS and peak to peak ripple/noise on the outputs of the UUT. It is possible to include or reject low frequency hum and to set the upper bandwidth of the measurement to exclude unwanted high frequency components.

Timer

Measures rise/fall times, inter-rail timing, programmable thresholds and slopes on two channels. There are 2 programmable analog channels and one TTL channel, each programmable channel can have two thresholds and slopes programmed.

DC and AC Voltage Measurement

Full auto ranging on all AC and DC inputs.

Technical Specifications

Frequency Measurement Ranges	30Hz to 750kHz, 30Hz to 150kHz (user selectable)
Programmable Threshold Range	±100V DC
DC Input Voltage Range	Accuracy
0-600mV	±0.05% of Range
0-2V	±0.03% of Range
0-6V	±0.02% of Range
0-20V	±0.02% of Range
0-60V	±0.02% of Range
0-100V	±0.02% of Range
DC Input Impedance	1MΩ
AC Input Voltage @ 50Hz	Accuracy
0-400mV rms	±0.1% of Range
0-1.4V rms	±0.1% of Range
0-4.2V rms	±0.1% of Range
0-14V rms	±0.1% of Range
0-42V rms	±0.1% of Range
0-70V rms	±0.1% of Range
Interval Timing	2 analog channels, 2 programmable thresholds and slopes per channel, 1 TTL channel
Bandwidth	1MHz
Measurement Range (Time)	5μs - 10s
Accuracy	±2μs
Threshold Accuracy	±1% of DC input voltage range
Ripple Noise	
Voltage Range Peak to Peak	50mV, 200mV, 500mV, 2V
Bandwidth	5kHz to 20MHz
Accuracy	±5% of range
Measurement Window	Programmable 1ms-200ms
Minimum Noise Measurement	10mV Pk-Pk, 3.5m Vrms
Operating Conditions	
Operating Temperature	5°C to 40°C
Storage Temperature	5°C to 70°C
Humidity	10% to 85% relative
Safety	Meets the safety guidelines laid down in the EN 61010-1 standard
Ordering Information	
Part Number	721-0001 (for a 6U Rack) 722-0002 (for a 1U Assembly)
Description	E2010 Measurement Module

Ripple Measurement Card - E2010 Series

- ETHERNET BASED CONTROLLER
- CONTROLS ALL TEST SYSTEM RESOURCES OVER A SINGLE BUS
- INTEGRATED WEB SERVER
- REMOTE SYSTEM CONTROL

The basic function of the Ripple/Noise card is to measure the output ripple and noise from Power Supplies. This is available as an RE2010 module which is for a 6U high rack or as a 1U standalone Ethernet Instrument.

FEATURES

- Ethernet control
- RMS value of noise
- Peak to peak value of noise
- The underlying peak-to-peak ripple voltage (while rejecting switching spikes less than a specified width).

The Ripple/Noise card consists of an Analog Board and a Digital Board.

The Pre-Amp section provides 50 ohm input impedance. The Pre-Amp section includes a selectable low frequency high pass filter with the bandwidth programmable to either 20Hz or 2kHz. This allows line frequency components to be eliminated from measurement if so desired. This filter also removes the DC component from the input signal. The Pre-Amp section incorporates input protection diodes, which protect the following stages from the surge of current, which occurs when a large DC Voltage is applied to the input of the unit.

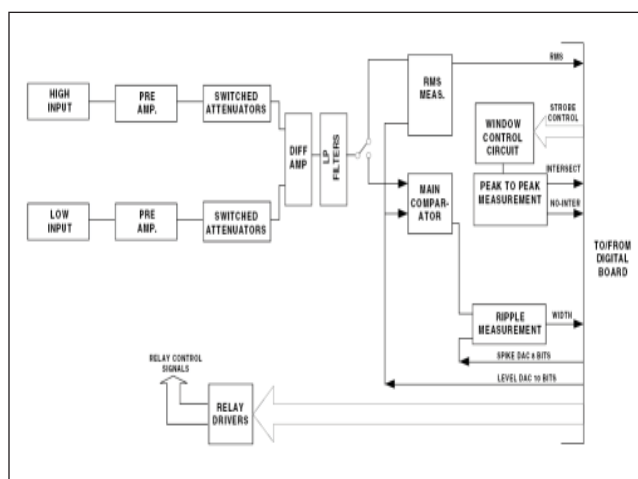

Ripple Measurement Block Diagram



Ripple Measurement Card

The differential amplifier section provides a single-ended output to the measurement sections. The differential amplifier also provides a good common mode rejection ratio. To measure Ripple or Noise within a reduced frequency range, a command is used to switch in one of a number of low pass filters. The signal at the output of the L.P. Filters section is passed to the measurement circuits. All the measurements are based on a successive approximation technique using the Level signal from the Digital Board. The window control circuit which allows the peak to peak measurement section to distinguish between periodic and random deviations. A major feature of the Digital Board is that through the use of opto-couplers the measurement section is isolated from the controlling computer and is thus floating. The measurement technique used involves checking the status of a number of signals which are read back from the Analog Board and are passed, in serial format, to the system control bus.

Technical Specifications

Ripple Measurement Card

Mode	Range 1	Range 2	Range 3	Range 4
Full Scale Range				
Ripple/Peak-Peak	2.0V	500mV	50mV	20mV
RMS	0.707V	177mV	17.7mV	7.07mV
Resolution				
Ripple/Peak-Peak	20mV	2mV	0.2mV	0.08mV
RMS	6mV	0.6mV	60uV	24uV
Accuracy				
Ripple/Peak-Peak	5% +/-60mV	5% +/-6mV	5% +/-0.6mV	5% +/-0.24mV
RMS	5% +/-20mV	5% +/-2mV	5% +/-0.2mV	5% +/-0.08mV
Bandwidth	The Ripple/Noise card can measure Ripple on power supplies with switching frequencies up to 50MHz. In Peak-to-Peak mode switching spikes as narrow as 10ns can be detected.			
R.M.S.Mode:	40Hz - 300kHz (16% Full Scale to Full Scale) 40Hz - 50kHz (below 16% Full Scale)			
All Modes:	Lower Bandwidth selectable at 2kHz providing 30dB rejection at 50/60Hz line frequency. May be used to eliminate hum components from reading. Upper bandwidth can be limited to 100kHz, 1MHz or 10MHz.			
Input Ratings				
Max. Voltage (AC + DC)	50V			
Impedance:	50 Ohm AC Coupled			
Common Mode Rejection Ratio	50 dB			
Spike Width Range:	20% to 1% of Switching Period 10ns Minimum.			
Safety				
Meets the safety requirements laid down in the following standard: IEC 1010				
Ordering Information				
Part Number	721-0002 (for a 6U Rack) 722-0002 (for a 1U Assembly)			
Description	E2010 Ripple Measurement Card			

INTEPRO
SYSTEMS

www.InteproATE.com

INTEPRO SYSTEMS EU/IRELAND

1530 S. Lyon Street
Santa Ana, CA 92705
USA

Tel: +1.714.679.9749

Fax: +1.714.953.3150

EU/IRELAND

Intepro Systems
Lonsdale Road,
National Technology Park
Limerick / Ireland

Tel: +353.61.33.22.33

Fax: +353.61.33.25.84

UNITED KINGDOM

Intepro Systems
1 Lakeside Business Park
Swan Lane, Sandhurst
Berkshire GU47 9DN / UK

Tel/Fax: +44.1252.875.600

CHINA

No.2405, Block D
Shahe Century Holiday Plaza
Nanshan District
Shenzhen, China 518053

Tel: +86 755 86398564

Fax: +86 755 86398567

Standard Scanner - E2010 Series

- HIGH SPEED, RELIABLE, SIGNAL SWITCHING PLUG-IN MODULE FOR E2010
- SELECTABLE SINGLE ENDED, DIFFERENTIAL AND FOUR WIRE MODE
- FUSE PROTECTION ON RELAY SCANNER BLOCKS
- IDEAL FOR DENSE TEST POINT SCANNING OR MATRIX REQUIREMENTS

The E2010 Standard Scanner module is designed for reliable, high speed switching of test measurement signals. This is available as an RE2010 module which is for a 6U high rack or as a 1U standalone Ethernet Instrument.

The E2010 Standard Scanner module is designed for reliable, high speed switching of test measurement signals.

It can be easily configured via on board headers for switching 80 single switches per module, 2-wire 40 differential channels per module, or 4-wire 20 channels per module, signal measurements.

The most common application of this module is scanning test signals from multiple points within a Device Under Test (DUT) through to a system measurement instrument such as a DVM. The 4-wire scanning mode can be used in situations where high accuracy measurements of low value resistors or inductors are required.

The module can also be used in reverse mode as a signal multiplexer. This covers situations where there is a requirement to switch a low frequency signal (less than 150kHz through to a variety of points on a DUT under program control.

High quality test point scanning relays are used to ensure accurate and repeatable measurements within the voltage range specified.

The relays are protected by means of decoder logic and on-board fuses, and are arranged on the board in blocks of 10 relays. Logic decoders ensure that only one relay on any block can be closed at any time.

The outputs of each block are independently fused to ensure that if a short circuit path is created in any measurement loop, the relays and board tracks will not be destroyed.

This can be critical in high power, high voltage test situations such as Power Supply testing or EMC testing.

The module is designed for simple plug in insertion into an E2010 backplane rack.



Standard Scanner Module

Connection to the module is via two 50 way D type connectors. The density of the E2010 Standard Scanner ensures that it is the most economical solution available for high speed ATE applications requiring multiple test points.

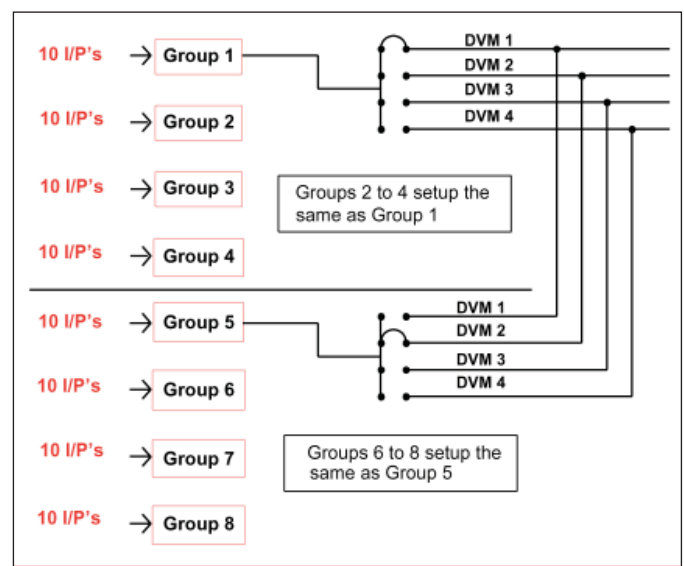

Module Configured in forty channel differential mode

Technical Specifications

Relay Form	Single Pole Single Throw
Maximum Voltage	150V DC
Maximum Current	100mA at Max Voltage
Contact Resistance	0.1Ω
Operate Time	1.2ms Max
Release Time	1ms Max
User Note Connection	
	Two male 50-way d type connector for user scanner input. One 9-way D type for output connection to DVM. The output is also present on the backplane connectors and may be routed this way if preferred.
MODULE CHARACTERISTICS	
Dimensions	233mm x 220mm x 45mm
Operating Temperature	5°C to 40°C
Storage Temperature	10% to 85% Relative
Bandwidth	150kHz
Humidity	5°C to 70°C
ORDERING INFORMATION	
Part Number	721-0003 (for a 6U Rack) 722-0003 (for a 1U Assembly)
Description	E2010 Standard Scanner

INTEPRO
SYSTEMS

www.InteproATE.com

INTEPRO SYSTEMS EU/IRELAND

1530 S. Lyon Street
Santa Ana, CA 92705
USA

Tel: +1.714.679.9749

Fax: +1.714.953.3150

EU/IRELAND

Intepro Systems
Lonsdale Road,
National Technology Park
Limerick / Ireland

Tel: +353.61.33.22.33

Fax: +353.61.33.25.84

UNITED KINGDOM

Intepro Systems
1 Lakeside Business Park
Swan Lane, Sandhurst
Berkshire GU47 9DN / UK

Tel/Fax: +44.1252.875.600

CHINA

No.2405, Block D
Shahe Century Holiday Plaza
Nanshan District
Shenzhen, China 518053

Tel: +86 755 86398564

Fax: +86 755 86398567

5A Load Module - E2010 Series

- CAN BUS AND CANOPEN PROTOCOL COMPATIBLE
- ARBITRARY WAVEFORM GENERATOR ALLOWS MULTIPLE SETTINGS AND WAVEFORMS TO BE PROGRAMMED
- REMOTE SENSE FOR ACCURATE VOLTAGE MEASUREMENT OF THE UUT

The 50W DC Load module is designed for use in an E2010 test system. The unit is 261mm (6U) high, approximately 390mm deep, and fits into a 19-inch rack. This is available as an RE2010 module which is for a 6U high rack or as a 1U standalone Ethernet Instrument.

FEATURES

- Programmable slew rate performance
- 1kV Isolation
- Analog to digital converter for on-board measurement of voltage and current to 15-bit resolution

System Setup

The 50W Load can calculate and limit its power dissipation and has the ability to switch the rack fans to a higher speed when necessary to increase cooling.

On the system unit, a controller module, 20mm (4HP) wide, is used to communicate with the host PC over an IEEE link. In addition, the controller module relays commands and information over the internal CAN bus.

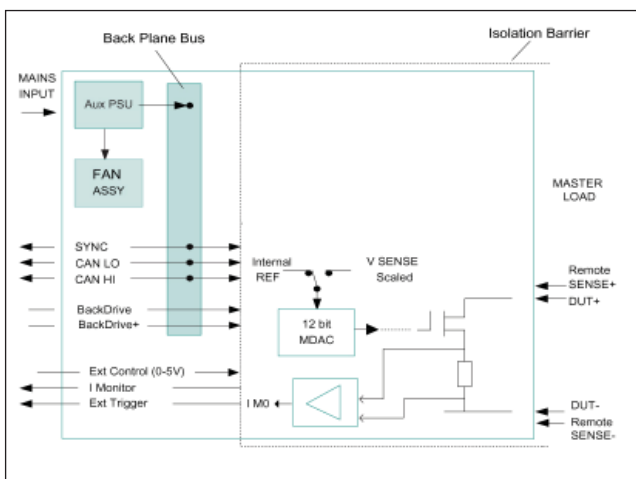

System Load Block Diagram



50 Watt DC Load

Each Load in a rack system can be addressed individually as each back plane PCB slot has a unique address.

Each load possesses local intelligence in the form of a microcontroller. This enables more efficient operation of constant voltage mode.

Each slot in a rack has a unique address read by the Load on power up. Each rack in a system has a unique rack address set by the user with DIL switches.

These two addresses combine to give the load a unique CAN ID in the system.

Intepro engineers designed the 50W DC Load to enable high slew rate performance and efficient operation of constant voltage. This DC load also boasts high resolution and greater current accuracy due to a lower current range.

Technical Specifications

POWER	5W	50W	Operating Voltage below 1V				0.3V@2.5A / 0.15V@1.25A	
CURRENT	0-0.5A	0-5A	Min Voltage on Full Load				0.6V@5A	
VOLTAGE	1-75V	1-75V	Module Power Consumption				12V@0.4A	
	Constant I Mode		Constant V Mode					
RANGE	0-0.5A	0-5A	1-2V	1-7.5V	1-20V	1-75V		
RESOLUTION	0.125mA	1.25mA	0.5mV	2mV	5mV	20mV		
ACCURACY	± 0.15%FS	± 0.05%SET±4mA	±15mV	±20mV	±40mV	±120mV		
TEMP. COEF.	Maximum 100 PPM/°C		Maximum 100 PPM/°C					
CONSTANT R MODE	Range		Resolution	Accuracy		Temp Coefficient		
0-2V INPUT RANGE	9.35S-2.5S / 0R107-OR 4		2.36mS	±1% SET ±15mA		200 PPM/°C		
0-7.5V INPUT RANGE	2.5S-0.94S / OR4-1R067		0.63mS	±1% SET ±15mA		200 PPM/°C		
0-20V INPUT RANGE	0.94S-0.25S / 1R067- 4R		0.236mS	±1% SET ±15mA		200 PPM/°C		
0-75V INPUT RANGE	0.25S - 63µS / 4R-16K		63µS	±1% SET ±15mA		200 PPM/°C		
MEASUREMENT	Range		Resolution	Accuracy		Output		
VOLTAGE READBACK	0-2V		15bit (62.5µV)	±0.05% ACT ±5mV		N/A		
	0-7.5V		15bit (0.23mV)	±0.05% ACT ±0.1%FS		N/A		
	0-20V		15bit (0.625mV)	±0.05% ACT ±0.1%FS		N/A		
	0-75V		15bit (2.3mV)	±0.05% ACT ±0.1%FS		N/A		
CURRENT READ-BACK	0-0.5A (Low)		0.015mA (Low)	±0.05% ACT ±0.75mA		N/A		
	0-5A (High)		0.15mA (High)	±0.05% ACT ±0.25mA		N/A		
POWER READ-BACK	0-5W	0-50W	0.0625mW	0.125mW		N/A		
CURRENT MONITOR OUTPUT	0-0.5A	0-5A	N/A	±1% FS		0-5V		
SLEW RATE	2mA/µs~0.5µs for 0 to 5A operation							
EXTERNAL CONTROL	0-5V gives 0 to full-scale current (5A)							
OPERATING TEMP.	5-40°C (Note: For ambient temperatures over 35°C, power dissipation derates by 4W/°C)							
DIMENSIONS	261mm (Height) 40mm (Width) 390mm (Depth)							
ORDERING INFORMATION								
Part Number:	721-0004 (for a 6U Rack) 722-0004 (for a 1U Assembly)							
Description	5A/75V/50-Watt Load							

INTEPRO
SYSTEMS

www.InteproATE.com

INTEPRO SYSTEMS EU/IRELAND

1530 S. Lyon Street
Santa Ana, CA 92705
USA

Tel: +1.714.679.9749

Fax: +1.714.953.3150

EU/IRELAND

Intepro Systems
Lonsdale Road,
National Technology Park
Limerick / Ireland

Tel: +353.61.33.22.33

Fax: +353.61.33.25.84

UNITED KINGDOM

Intepro Systems
1 Lakeside Business Park
Swan Lane, Sandhurst
Berkshire GU47 9DN / UK

Tel/Fax: +44.1252.875.600

CHINA

No.2405, Block D
Shahe Century Holiday Plaza
Nanshan District
Shenzhen, China 518053

Tel: +86 755 86398564

Fax: +86 755 86398567

Dual Load - E2010 Series

- TWO FULLY ISOLATED ELECTRONIC LOADS, EACH 150 WATTS
- OPERATES STANDALONE OR PARALLEL FOR 300 WATTS
- CONSTANT CURRENT, POWER, AND RESISTANCE MODES
- HIGH SPEED OPERATION, LESS THAN 25USEC LOOP RESPONSE

The E2010 Dual load module is ideal for providing modular load capability in any automatic test system. Each load is fully featured and provides 150Watts of isolated load sink capability, a total of 300Watts per module. This is available as an RE2010 module which is for a 6U high rack or as a 1U standalone Ethernet Instrument.

Multiple modules can be configured in parallel to facilitate higher power outputs. Each E2010 rack can accommodate up to 10 load modules (2.7Kwatts per rack) and multiple racks can be configured in a system.

This makes the Intepro E2010 load system one of the most cost effective and modular load facilities available on the market today. Each load is fully programmable with twelve (12) bit resolution. In addition each load has two ranges to improve overall program accuracy. Each load can operate in constant current and constant resistance mode. The load may also be modulated (pulsed) by an external signal source using the on board pulse relays. Each load also has built in relays to facilitate easy O.V.P. (backdrive) testing in a power supply test system. Each load is also electronically protected from Over Power, Over Current and Over Temperature. This is a key feature to ensure reliable operation in the harsh environments of power supply testing.

The module also has a jumper selectable loop response time setting. The load can be operated at high speed in normal functional test systems. However, the loop response can be slowed down in applications such as Burnin where there may be very significant

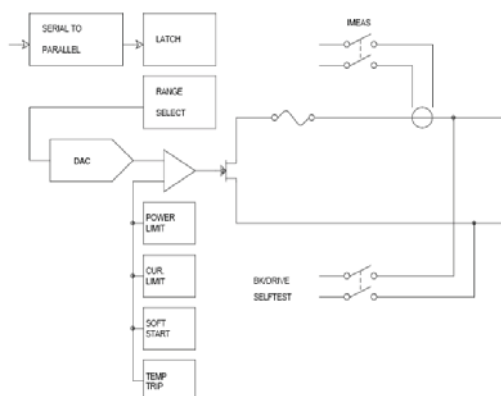

Dual Load

lead lengths in the fixture wiring to the units. The inductance associated with long wire lengths could cause the load to oscillate if the loop response was too fast.

The module is fully supported by POWERSTAR software platforms supplied by Intepro.

The module is designed for simple plug in insertion into an E2010 backplane system (low cost).

User connection to the module is via Positronic 7W2 female connectors. This facilitates high power and signal connection in one easy to remove connector.

The E2010 Dual load is ideal for high specification, medium power, load requirements in an ATE system.

Technical Specifications

	Range	Resolution	Accuracy	
Constant Current	Range 1	0A to 7.5A	2mA	+/- (0.25 % setting + resolution + 3mA)
	Range 2	0A to 30A	8mA	+/- (0.25 % setting + resolution + 3mA)
Constant Resistance	Range 1	0.0667R to 0.667R	0.004*Vin	+/- (0.25% setting 3+ (0.004*vin +3mA))
	Range 2	0.667R to 2730R	0.0004*Vin	+/- (0.25% setting + (0.0004*vin +3mA))
Power Rating	150 Watts max (per load)			
Response time	20uSec (min) - 200uSec (max)		(jumper selectable)	
Operating temp	0degC to 55DegC			
Measure accuracy	0.25 % of actual current+3mA			
Input voltage range	0.5V to 100V DC			
Humidity	10% to 85% Relative			
ORDERING INFORMATION				
Part Number:	721-0005 (for a 6U Rack) 722-0005 (for a 1U Assembly)			
Description	30A/100V/150-Watt Dual Load			

INTEPRO
SYSTEMS

www.InteproATE.com

INTEPRO SYSTEMS EU/IRELAND

1530 S. Lyon Street
Santa Ana, CA 92705
USA
Tel: +1.714.679.9749
Fax: +1.714.953.3150

EU/IRELAND

Intepro Systems
Lonsdale Road,
National Technology Park
Limerick / Ireland
Tel: +353.61.33.22.33
Fax: +353.61.33.25.84

UNITED KINGDOM

Intepro Systems
1 Lakeside Business Park
Swan Lane, Sandhurst
Berkshire GU47 9DN / UK
Tel/Fax: +44.1252.875.600

CHINA

No.2405, Block D
Shahe Century Holiday Plaza
Nanshan District
Shenzhen, China 518053
Tel: +86 755 86398564
Fax: +86 755 86398567

40A Load Module - E2010 Series

- REMOTE SENSE IN MASTER LOADS FOR ACCURATE VOLTAGE MEASUREMENT OF THE DUT
- CAN BUS AND CAN OPEN PROTOCOL COMPATIBLE
- ARBITRARY WAVEFORM GENERATOR ALLOWS MULTIPLE SETTINGS AND WAVEFORMS TO BE PROGRAMMED

The 200-Watt DC Load is a variable electronic unit which is capable of sinking up to 40 amps. This is available as an RE2010 module which is for a 6U high rack or as a 1U standalone Ethernet Instrument.

FEATURES

- Programmable slew rate performance
- Parallelable
- Analog to digital converter for on-board measurement of voltage and current to 15-bit resolution
- 1kV isolation

Designed for use in an E2010 system, the 200W Load is 261mm(6U) high, approximately 390mm deep and fits into a 19-inch rack. Each Load possesses local intelligence in the form of a microcontroller. This enables more efficient operation of Constant Voltage mode.

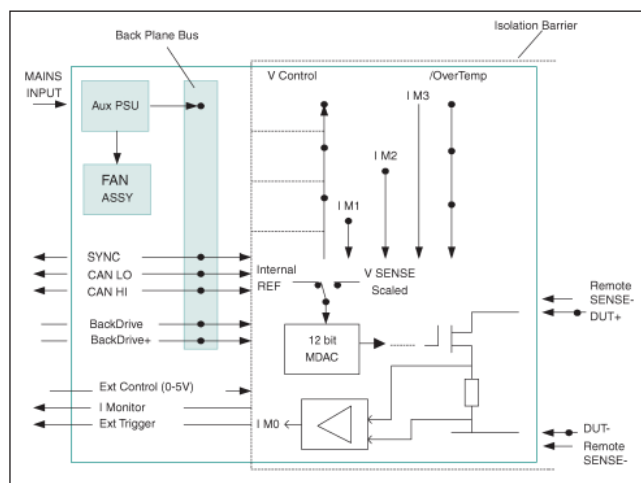

System Load Block Diagram

Controller Module

In an E2010 System, the Loads are controlled via a Controller Module (20mm /4HP wide) that is used to communicate with the host PC over an Ethernet link.

The Controller Module relays commands and information over the internal CAN bus to the Master Loads.



E2010
40A DC Load
721-0006



RE2010
40A DC Load
722-0006

Each Load in a rack system can be addressed individually, as each back plane PCB slot has a unique address.

The sense voltage from each Load can be daisy chained via RJ45 connectors and connected to a high speed Measurement Module which performs transient, peak, counting, timing, ripple and noise, DC, and AC tests on the DUT.

Constant I Mode		
Range	Resolution	Accuracy
0-4A	2.5mA	±0.05%SET±4mA
0-40A	25mA	±0.05%SET±4mA
Constant V Mode		
Range	Resolution	Accuracy
1-2V	0.5mV	±15mV
1-7.5V	2mV	±20mV
1-20V	5mV	±40mV
1-75V	20mV	±120mV

Technical Specifications

POWER	20W	200W	Operating Voltage below 1V	0.5V@20A/0.25V@10A
CURRENT	0-4A	0-40A	Min Voltage on Full Load	1V@40A
VOLTAGE	1-75V	1-75V	Module Power Consumption	12V@0.4A
TEMP. COEFFICIENT	Max 100PPM/°C			
CONSTANT R MODE	Range	Resolution	Accuracy	Temp Coefficient
0-2V INPUT RANGE	40S-20S / 0R025-0R05	19mS	±1% SET ±100mA	200PPM/°C
0-7.5V INPUT RANGE	20S-7.52S / 0R05-0R133	5mS	±1% SET ±100mA	200PPM/°C
0-20V INPUT RANGE	7.52S-2S / 0R133-0R5	1.9mS	±1% SET ±100mA	200PPM/°C
0-75V INPUT RANGE	2S-0.5mS / 0.5R-2K	0.5mS	±1% SET ±120mA	200PPM/°C
MEASUREMENT	Range	Resolution	Accuracy	Output
VOLTAGE READBCK	0-2V	15bit (62.5µV)	±0.05% ACT± 5mV	N/A
	0-7.5V	15bit (0.23mV)	±0.05% ACT ±0.1% FS	N/A
	0-20V	15bit (0.625mV)	±0.05% ACT ±0.1% FS	N/A
	0-75V	15bit (2.3mV)	±0.05% ACT ±0.1% FS	N/A
CURRENT READ- BACK	0-4A / 0-40A	0.125mA / 1.25mA	±0.05% ACT ±0.05%FS	N/A
POWER READBACK	0-20W / 0-200W	0.25mW / 5mW	±0.5% FS	N/A
CURRENT MONITOR OUTPUT ISOLATED	0-4A / 0-40A	N/A	±0.5% FS	N/A
SLEW RATE	16mA/µs ~ 4A/µs	16mA/ms	±10% SET ±10% FS	
EXTERNAL CON- TROL	0-5 V input gives 0-40A output			
OPERATING TEMP.	5°C to 40°C			
DIMENSIONS	261mm (H) 40mm (W) 390mm (D)			
FAMILY SPEC. SAFETY	OTP: (Over Temperature Protection):		Non Latching disable	
	OVP: (Over Voltage Protection):		Greater than 80V crowbar	
	Isolation Voltage to GND:		Safety (1000V DC Peak)	
	Reverse Connection Protection Action:		Fuse protects against overcurrent - no action at nominal current	
ORDERING INFORMATION	Part Number:		721-0006 (for a 6U Rack) 722-0006 (for a 1U Assembly)	
	Description:		40A/75V/200W	
SET: Refers to the set value			ACT: Refers to the set value	

INTEPRO
SYSTEMS

www.InteproATE.com

INTEPRO SYSTEMS EU/IRELAND

1530 S. Lyon Street
Santa Ana, CA 92705
USA
Tel: +1.714.679.9749
Fax: +1.714.953.3150

EU/IRELAND

Intepro Systems
Lonsdale Road,
National Technology Park
Limerick / Ireland
Tel: +353.61.33.22.33
Fax: +353.61.33.25.84

UNITED KINGDOM

Intepro Systems
1 Lakeside Business Park
Swan Lane, Sandhurst
Berkshire GU47 9DN / UK
Tel/Fax: +44.1252.875.600

CHINA

No.2405, Block D
Shahe Century Holiday Plaza
Nanshan District
Shenzhen, China 518053
Tel: +86 755 86398564
Fax: +86 755 86398567

100A Load Module - E2010 Series

- REMOTE SENSE FOR ACCURATE VOLTAGE MEASUREMENTS
- CAN BUS AND CANOPEN PROTOCOL COMPATIBLE
- OPTIMISED FOR LOW VOLTAGE OPERATION

The 200-Watt DC Load is a variable electronic unit which is capable of sinking up to 100 amps at low voltages. This is available as an RE2010 module which is for a 6U high rack or as a 1U standalone Ethernet Instrument.

Designed for use in an E2010 system, the 200W Load is 261mm(6U high, approximately 390mm deep and fits into a 19-inch rack. Each Load possesses local intelligence in the form of a microcontroller This enables more efficient operation of constant voltage mode.



RE2010
100 Amp DC Load
722-0007

FEATURES

- Programmable slew rate performance
- Analog to digital converter for measurement of voltage and current to 15-bit resolution
- 1kV isolation
- Parallelable
- 0.8V operation at 100A

Controller Module

In an Intepro 9000 System, the Loads are controlled via a Controller Module (20mm /4HP wide) that is used to communicate with the host PC over an IEEE link.

The Controller Module relays commands and information over the internal CAN bus to the Master Loads. Each Load in a rack system can be addressed individually, as each back plane PCB slot has a unique address.

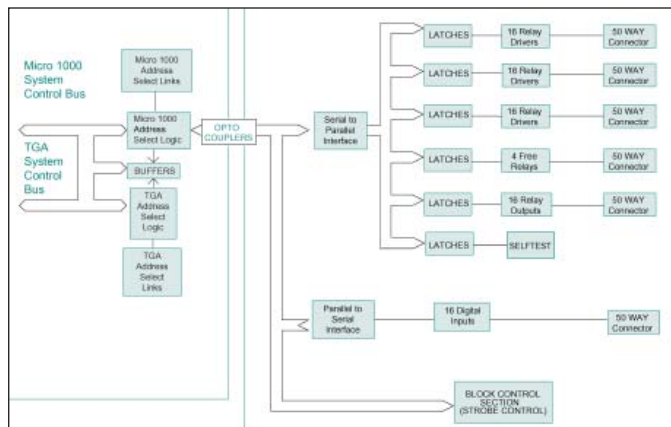

System Load Block Diagram



E2010
100 Amp DC Load
721-0007

The sense voltage from each Load can be daisy chained via RJ45 connectors and connected to a high speed Measurement Module which performs transient, peak, counting, timing, ripple and noise, DC, and AC tests on the DUT.

Constant I Mode		
Range	Resolution	Accuracy
0-10A	2.5mA	±0.05%SET±10mA
0-100A	25mA	±0.05%SET±50mA
Constant V Mode		
Range	Resolution	Accuracy
0.8-2V	0.5mV	±15mV
0.8-7.5V	2mV	±20mV
0.8-20V	5mV	±40mV
0.8-30V	20mV	±120mV

Technical Specifications

POWER	20W	200W	Operating Voltage below 0.8V	0.4V@50A/0.2V@25A
CURRENT	0-10A	0-100A	Min Voltage on Full Load	0.8V@100A
VOLTAGE	0.8-30V	0.8-30V	Module Power Consumption	12V@0.4A
TEMP. COEFFICIENT	Max 100PPM/°C			
CONSTANT R MODE	Range	Resolution	Accuracy	Temp Coefficient
0-2V INPUT RANGE	125S-50S/0R008-0R02	47.5mS	±1% SET ±250mA	200PPM/°C
0-7.5V INPUT RANGE	50S-7.52S/0R02-0R133	12.5mS	±1% SET ±250mA	200PPM/°C
0-20V INPUT RANGE	7.52S-2S/0R133-0R5	4.75mS	±1% SET ±250mA	200PPM/°C
0-30V INPUT RANGE	2S-0.5mS/0.5R-2K	1.25mS	±1% SET ±300mA	200PPM/°C
MEASUREMENT	Range	Resolution	Accuracy	Output
VOLTAGE READBACK	0-2V	15bit (62.5µV)	±0.05% ACT± 5mV	N/A
	0-7.5V	15bit (0.23mV)	±0.05% ACT ±0.1% FS	N/A
	0-20V	15bit (0.625mV)	±0.05% ACT ±0.1% FS	N/A
	0-30V	15bit (2.3mV)	±0.05% ACT ±0.1% FS	N/A
CURRENT READBACK	0-10A/0-100A	0.313mA/3.13mA	±0.05% ACT ±0.05%FS	N/A
POWER READBACK	0-20W/0-200W	0.25mW / 5mW	±0.5% FS	N/A
CURRENT MONITOR OUTPUT ISOLATED	0-10A/0-100A	N/A	±0.5% FS	N/A
SLEW RATE	16mA/µs ~ 4A/µs	16mA/ms	±10% SET ±10% FS	
EXTERNAL CONTROL	0-5V input gives 0-100A output			
OPERATING TEMP.	5°C to 40°C			
DIMENSIONS				
FAMILY SPEC. SAFETY	OTP: (Over Temperature Protection):	Non Latching disable		
	OVP: (Over Voltage Protection):	Greater than 35V crowbar		
	Isolation Voltage to GND:	Safety (1000V DC Peak)		
	Reverse Connection Protection Action:	Fuse protects against overcurrent - no action at nominal current		
ORDER INFORMATION	Part Number:	721-0007 (for a 6U Rack) 722-0007 (for a 1U Assembly)		
	Description:	100A/30V/200W Load		
SET: Refers to the set value		ACT: Refers to the set value		

INTEPRO
SYSTEMS

www.InteproATE.com

INTEPRO SYSTEMS EU/IRELAND

1530 S. Lyon Street
Santa Ana, CA 92705
USA
Tel: +1.714.679.9749
Fax: +1.714.953.3150

EU/IRELAND

Intepro Systems
Lonsdale Road,
National Technology Park
Limerick / Ireland
Tel: +353.61.33.22.33
Fax: +353.61.33.25.84

UNITED KINGDOM

Intepro Systems
1 Lakeside Business Park
Swan Lane, Sandhurst
Berkshire GU47 9DN / UK
Tel/Fax: +44.1252.875.600

CHINA

No.2405, Block D
Shahe Century Holiday Plaza
Nanshan District
Shenzhen, China 518053
Tel: +86 755 86398564
Fax: +86 755 86398567

Quad Load - E2010 Series

- FOUR FULLY ISOLATED ELECTRONIC LOADS, EACH 75 WATTS
- OPERATES STANDALONE OR PARALLEL FOR 300 WATTS
- CONSTANT CURRENT, POWER, AND RESISTANCE MODES
- HIGH SPEED OPERATION, LESS THAN 25USEC LOOP RESPONSE

The E2010 Quad load module is ideal for providing modular load capability in any automatic test system. Each load is fully featured and provides 75Watts of isolated load sink capability, a total of 300Watts per module. This is available as an RE2010 module which is for a 6U high rack or as a 1U standalone Ethernet Instrument.

Multiple modules can be configured in parallel to facilitate higher power outputs. Each E2010 rack can accommodate up to 10 load modules (2.7Kwatts per rack) and multiple racks can be configured in a system.

This makes the Intepro E2010 load system one of the most cost effective and modular load facilities available on the market today. Each load is fully programmable with twelve (12) bit resolution. In addition each load has two ranges to improve overall program accuracy. Each load can operate in constant current and constant resistance mode. The load may also be modulated (pulsed) by an external signal source using the on board pulse relays. Each load also has built in relays to facilitate easy O.V.P. (backdrive) testing in a power supply test system. Each load is also electronically protected from Over Power, Over Current and Over Temperature. This is a key feature to ensure reliable operation in the harsh environments of power supply testing.

The module also has a jumper selectable loop response time setting. The load can be operated at high speed in normal functional test systems. However, the loop response can be slowed down in applications such as Burnin where there may be very significant lead lengths in the fixture wiring to the units. The inductance associated with long wire lengths could cause the load to oscillate if the loop response was too fast.

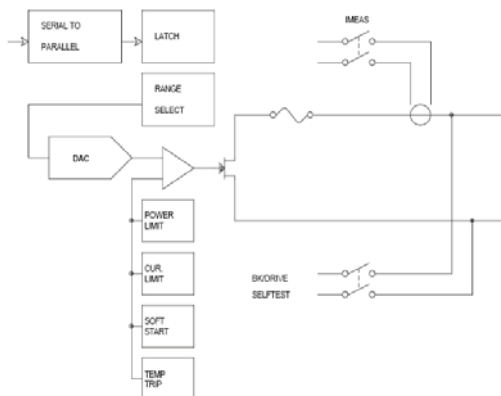

Quad Load

The module is fully supported by POWERSTAR software platforms supplied by Intepro.

The module is designed for simple plug in insertion into an E2010 backplane system (low cost).

User connection to the module is via Positronic 7W2 female connectors. This facilitates high power and signal connection in one easy to remove connector.

The E2010 Quad load is ideal for high specification, medium power, load requirements in an ATE system.

Technical Specifications

	Range	Resolution	Accuracy	
Constant Current	Range 1	0A to 7.5A	2mA	+/- (0.25 % setting + resolution + 3mA)
	Range 2	0A to 15A	8mA	+/- (0.25 % setting + resolution + 3mA)
Constant Resistance	Range 1	0.0667R to 0.667R	0.004*Vin	+/- (0.25% setting 3+ (0.004*vin +3mA))
	Range 2	0.667R to 2730R	0.0004*Vin	+/- (0.25% setting + (0.0004*vin +3mA))
Power Rating	75 Watts max (per load)			
Response time	20uSec (min) - 200uSec (max)		(jumper selectable)	
Operating temp	0degC to 55DegC			
Measure accuracy	0.25 % of actual current+3mA			
Input voltage range	0.5V to 100V DC			
Humidity	10% to 85% Relative			
ORDERING INFORMATION				
Part Number:	721-0008 (for a 6U Rack) 722-0008 (for a 1U Assembly)			
Description	15A/100V/75-Watt Quad Load			

INTEPRO
SYSTEMS

www.InteproATE.com

INTEPRO SYSTEMS EU/IRELAND

1530 S. Lyon Street
Santa Ana, CA 92705
USA

Tel: +1.714.679.9749

Fax: +1.714.953.3150

EU/IRELAND

Intepro Systems
Lonsdale Road,
National Technology Park
Limerick / Ireland

Tel: +353.61.33.22.33

Fax: +353.61.33.25.84

UNITED KINGDOM

Intepro Systems
1 Lakeside Business Park
Swan Lane, Sandhurst
Berkshire GU47 9DN / UK

Tel/Fax: +44.1252.875.600

CHINA

No.2405, Block D
Shahe Century Holiday Plaza
Nanshan District
Shenzhen, China 518053

Tel: +86 755 86398564

Fax: +86 755 86398567

4A Relay Module - E2010 Series

- FLEXIBLE HIGH POWER SWITCHING UP TO 4AMPS / 250V AC / 30V DC
- NORMALLY OPEN AND NORMALLY CLOSED
- IDEAL FOR UTILITY POWER SWITCHING IN ANY TEST SYSTEM

The E2010 4 Amp power relay module is designed for high density cost effective utility switching in an automatic test system. This is available as an RE2010 module which is for a 6U high rack or as a 1U standalone Ethernet Instrument.

There are 24 double pole double throw (DPDT) relays on each module. The relays provide a convenient method of switching power signals within the test system. The fact that the on board relays are rated at 220V AC means that mains signals (less than 4A) can be switched in a test application without the need for fitting contactors in the device under test (DUT) fixture.

Typical application of this module include switching Power Resistors in binary selectable AC load. Turning on and off fans in the fixture and DUT. Short circuiting outputs. Connecting DUT outputs in parallel under program control. Discharging large capacitors under program control, and so on.

Due to the high power switching capability of this module all of the switching circuits are enclosed in an EMI screen to minimize any interference with neighbouring modules in the rack.

Both the normally OPEN and the normally CLOSED contact of each relay are available at the user connectors on the front of the module. If sufficient consideration is given to selecting the right type and number of free relays in a system the users DUT fixturing can usually be reduced to contain simple wiring only.

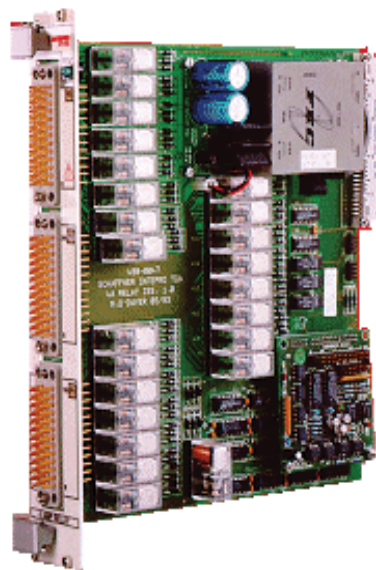

4 Amp Relay Module

The module is fully supported by the POWERSTAR software platforms supplied by Intepro.

The module is designed for simple plug in insertion into an E2010 backplane system (low cost) or into a 1U Ethernet Instrument.

The user interface to the module is via three 24 way Positronic bulk connectors (PLC24F0050) This facilitates swift connection and disconnection in an ATE system.

The E2010 4A relay card is ideal for cost effect, reliable, high density, medium power switching.

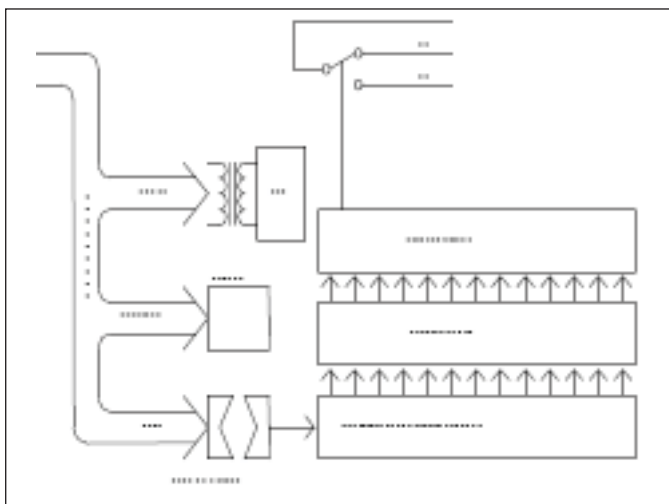

4A Relay Block Diagram

Technical Specifications

Relay Form	Double Pole Double Throw (DPDT)
Maximum Voltage	250V AC /125V DC
User connections	Three 24 way Positronic Connectors (PLC2F0050) (Pin inserts FS114N2)
Maximum current	4 A @ 250V AC/30V DC
Contact resistance	50mOhms
Operate time	15 mS Max
Release time	10mS Max
Operating Conditions	
Operating Temperature	5°C to 40°C
Humidity	10% to 85% relative
Storage Temperature	25°C to 70°C
Dimensions	233mm x 220mm x 45mm
Ordering Information	
Part Number	721-0015 (for a 6U Rack) 722-0015 (for a 1U Assembly)
Description	E2010 4A Relay Module

INTEPRO
SYSTEMS

www.InteproATE.com

INTEPRO SYSTEMS

1530 S. Lyon Street
Santa Ana, CA 92705
USA

Tel: +1.714.679.9749

Fax: +1.714.953.3150

EU/IRELAND

Intepro Systems
Lonsdale Road,
National Technology Park
Limerick / Ireland

Tel: +353.61.33.22.33

Fax: +353.61.33.25.84

UNITED KINGDOM

Intepro Systems
1 Lakeside Business Park
Swan Lane, Sandhurst
Berkshire GU47 9DN / UK

Tel/Fax: +44.1252.875.600

CHINA

No.2405, Block D
Shahe Century Holiday Plaza
Nanshan District
Shenzhen, China 518053

Tel: +86 755 86398564

Fax: +86 755 86398567

15A Relay Module - E2010 Series

- FLEXIBLE HIGH POWER SWITCHING UP TO 15AMPS / 250V AC / 30V DC
- NORMALLY OPEN AND NORMALLY CLOSED
- IDEAL FOR UTILITY POWER SWITCHING IN ANY TEST SYSTEM

The E2010 15 Amp power relay module is designed for cost effective utility switching in an automatic test system. This is available as an RE2010 module which is for a 6U high rack or as a 1U standalone Ethernet Instrument.

There are 24 single pole double throw (SPDT) relays on each module. The relays provide a convenient method of switching power signals within the test system. The relays being rated at 250V AC means that mains signals (less than 15A) can be switched in a test application without the need for fitting contactors in the device under test (DUT) fixture.

Typical applications of this module include switching DUT input power ON and OFF. Turning on and off fans in the fixture and DUT. Short circuiting outputs. Connecting DUT outputs in parallel under program control. Discharging large capacitors under program control, and so on.

Due to the high power switching capability of this module all of the switching circuits are enclosed in an EMI screen to minimize any interference with neighbouring modules in the rack.

Both the normally OPEN and the normally CLOSED contact of each relay are available at the user connectors on the front of the module. If sufficient consideration is given to selecting the right type and number of free relays in a system the users DUT fixturing can usually be reduced to contain simple wiring only.

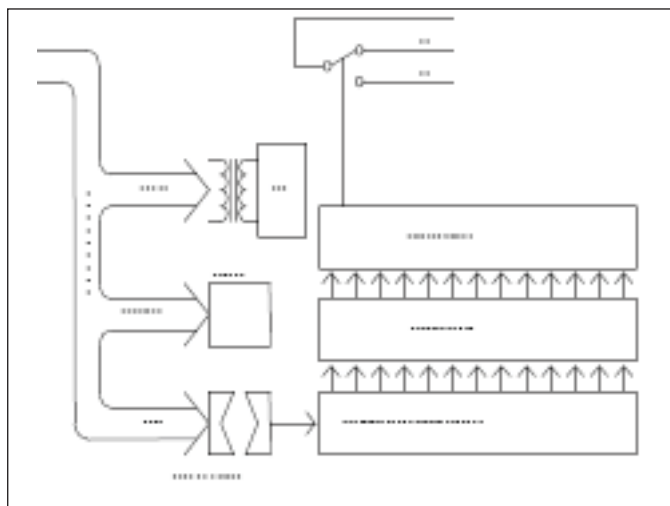

15A Relay Block Diagram



15A Relay Module

The module is fully supported by the POWERSTAR software platforms supplied by Intepro.

The module is designed for simple plug in insertion into an E2010 backplane system (low cost) or into any standard Ethernet 1U Instrument Rack.

The user interface to the module is via three 24 way Positronic bulk connectors (PLC24F0050). This Facilitates swift connection and disconnection in an ATE system.

The E2010 15A power relay card is ideal for cost effect, reliable, high density power switching.

Technical Specifications

Relay Form	Single Pole Double Throw (SPDT)
Maximum Voltage	250V AC /125V DC
User connections	Three 24 way Positronic Connectors (PLC2F0050) (Pin inserts FS114N2)
Maximum current	15 A @ 250V AC/30V DC
Contact resistance	50mOhms
Operate time	15 mS Max
Release time	10mS Max
Operating Conditions	
Operating Temperature	5°C to 40°C
Humidity	10% to 85% relative
Storage Temperature	25°C to 70°C
Dimensions	233mm x 220mm x 45mm
Ordering Information	
Part Number	721-0016 (for a 6U Rack) 722-0016 (for a 1U Assembly)
Description	E2010 15A Relay Module

INTEPRO
SYSTEMS

www.InteproATE.com

INTEPRO SYSTEMS

1530 S. Lyon Street
Santa Ana, CA 92705
USA

Tel: +1.714.679.9749

Fax: +1.714.953.3150

EU/IRELAND

Intepro Systems
Lonsdale Road,
National Technology Park
Limerick / Ireland

Tel: +353.61.33.22.33

Fax: +353.61.33.25.84

UNITED KINGDOM

Intepro Systems
1 Lakeside Business Park
Swan Lane, Sandhurst
Berkshire GU47 9DN / UK

Tel/Fax: +44.1252.875.600

CHINA

No.2405, Block D
Shahe Century Holiday Plaza
Nanshan District
Shenzhen, China 518053

Tel: +86 755 86398564

Fax: +86 755 86398567

Multifunction Module - E2010 Series

- MULTIFUNCTION MODULE FOR E2010 SYSTEMS
- 48 HIGH CURRENT RELAY DRIVERS PER MODULE
- 16 BIT DIGITAL INPUT AND OUTPUT PORTS PER MODULE
- 4 FREE RELAYS PER MODULE

The E2010 Multifunction module is intended for providing control of multiple functions within an Intepro 9000 system. In situations that require a variety of control functions, this module offers a more cost effective solution than fitting separate Digital I/O cards, Relay cards and Driver cards to cover the same utility functions. This is available as an RE2010 module which is for a 6U high rack or as a 1U standalone Ethernet Instrument.

In addition, the Multifunction module could be used to control special "Black Boxes" that are developed for customer specific E2010 solutions. In this way special units such as Turbo Variacs or AC Resistor selectable loads are controlled directly by the Multifunction module and the "Black Box" unit looks like another E2010 module to the software.

For each Multifunction module there are forty eight (48) open collector relay driver outputs. These relay drivers are arranged in three blocks of sixteen. Each relay driver pin is rated up to 48V/250mA rating.

In addition, four (4) programmable single pole relays are available on each module for utility switching.

Each Multifunction module contains a separate sixteen (16) bit input and output port. These non isolated ports are hard wired for TTL logic levels.

Calibration is achieved via software routines and offset adjust-

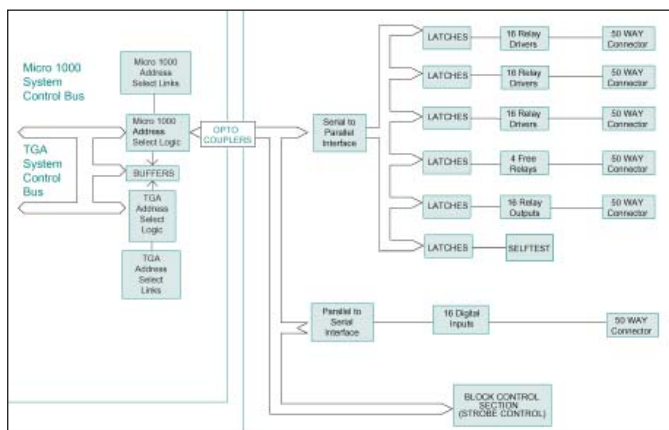

Multifunction module Block Diagram

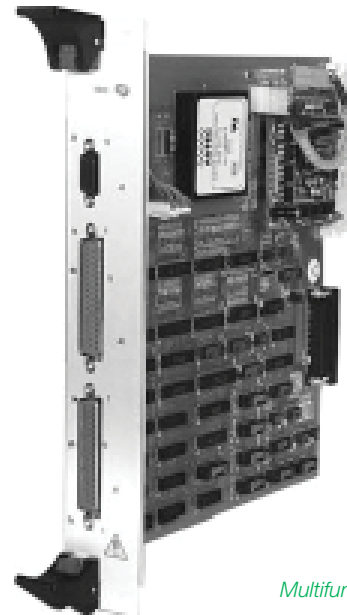

Multifunction Module

ments. There are no potentiometers on the module.

The calibration constants for the Multifunction module are stored in EEPROM on the module and therefore travel with each circuit. This can significantly reduce the time involved in calibrating a system in the field.

The Multifunction module is fully supported by PowerStar 5 software supplied by Intepro and is designed for simple plug-in insertion into an E2010 rack.

User connection to the module is via two 50 Way D Type connectors.

Technical Specifications

Free Relays

Voltage Rating	100VDC
Current Rating	1A Max

Relay Drivers - 48 per module

Voltage Rating	48VDC Max
Current Rating	250mA Max

Digital I/O - 1 input and 1 output port (TTL line)

Output	2.16mA
Input	0.7mA
Num. of bits	16 per port

Operating Conditions

Operating Temperature	5°C to 40°C
Humidity	10% to 85% relative
Storage Temperature	25°C to 70°C
Dimensions	161mm(H) x 50mm(W)

Ordering Information

Part Number	721-0030 (for a 6U Rack) 722-0030 (for a 1U Assembly)
Description	E2010 Digital I/O Module

INTEPRO
SYSTEMS

www.InteproATE.com

INTEPRO SYSTEMS

EU/IRELAND
1530 S. Lyon Street
Santa Ana, CA 92705
USA
Tel: +1.714.679.9749
Fax: +1.714.953.3150

EU/IRELAND

Intepro Systems
Lonsdale Road,
National Technology Park
Limerick / Ireland
Tel: +353.61.33.22.33
Fax: +353.61.33.25.84

UNITED KINGDOM

Intepro Systems
1 Lakeside Business Park
Swan Lane, Sandhurst
Berkshire GU47 9DN / UK
Tel/Fax: +44.1252.875.600

CHINA

No.2405, Block D
Shahe Century Holiday Plaza
Nanshan District
Shenzhen, China 518053
Tel: +86 755 86398564
Fax: +86 755 86398567

Selftest Scanner Module - E2010 Series

- FACILITATES SYSTEM SELFTEST DOWN TO MODULE LEVEL
- 14 SCANNER RELAY CHANNELS PER MODULE (100V)
- 10 FREE RELAYS (4A)

The Selftest Scanner Module is a dual purpose instrument. It acts as a reference and switching module for system Selftest, which is used in conjunction with a Selftest fixture and Selftest software. When the Relay Scanner is not in use as a Selftest application, it is available to be used as a general purpose scanning and switching card. The Relay Scanners in-built selftest is an essential component for “down” time minimization in any high volume manufacturing facility. This is available as an RE2010 module which is for a 6U high rack or as a 1U standalone Ethernet Instrument.

The Selftest facility is designed to help diagnose a failure down to the module level and in many cases component level. For example; checking system free relays will test each individual relay in both the open and closed position and identify a specific faulty relay on a free relay module.

Components of the Selftest option include:

- (1) E2010 Selftest Scanner Module
- (2) System Selftest Fixture
- (3) Selftest Software Package

The system Selftest fixture does not contain any active electronic components. Its purpose is to interconnect various parts of the system across the front panel; use of a simple passive (wiring only) Selftest fixture ensures a reliable Selftest option.

The Selftest software is structured in a modular fashion to check each of the “sub-systems” in the overall E2010 configuration. For example a separate check exists for DC sources, AC sources, Loads, Relays and so on.

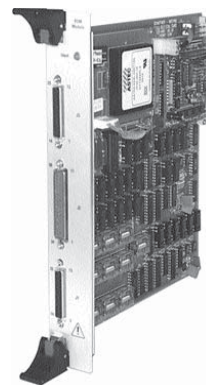
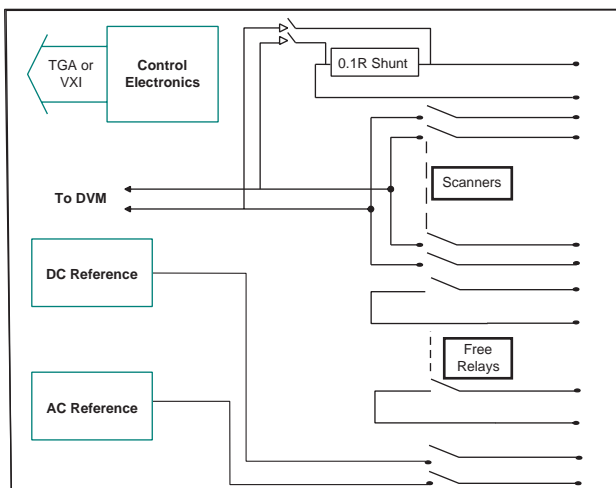

RE2010
Selftest Scanner Module Diagram
721-0040



E2010
Selftest Scanner Module Diagram
722-0040

The Selftest software will setup the E2010 Selftest Scanner Module to provide the relevant stimulus for each test block in Selftest. Selftest will generally checkout the complete chain of modules involved in a sub-system. One example would be, checking a system DC source, Selftest will control the DC source driver card and (via the Selftest fixture) connect the output of the source back to a suitable measurement unit and verify the programmed source voltage level. This verifies that not only is the driver card and DC source functional but that the wiring from the driver card to the source and the wiring from the source to the front panel is also operational.

The E2010 Selftest Scanner Module is designed for simple plug in insertion into an E2010 rack. Connection is via one 50 Way D Type connector and two 25 Way D Type connectors.

Technical Specifications

Circuit Functions	
Reference	5VDC/2.5VDC
Sine Reference	8Vpp@1.25kHz
Triangle Wave	8Vpp@1.25kHz
Square Wave1	24Vpp@1.25kHz
DC Pull-up	12V@150mA
Current Shunt	0.11WOhm±1%
Scanner Relays	14 channels per module (100V@100mA)
Free Relays	10 relays per module (30VDC@4Amps)
Module Characteristics	
Dimensions	261mm(H) x 220mm(D) x 50mm(W)
Operating Temperature	5°C to 40°C
Storage Temperature	-25° to 70°C
Humidity	10% to 85% relative non condensing
Ordering Information	
Part Number	721-0040 (for a 6U Rack) 722-0040 (for a 1U Assembly)
Description	E2010 Selftest Scanner

INTEPRO
SYSTEMS

www.InteproATE.com

INTEPRO SYSTEMS EU/IRELAND

1530 S. Lyon Street
Santa Ana, CA 92705
USA

Tel: +1.714.679.9749

Fax: +1.714.953.3150

EU/IRELAND

Intepro Systems
Lonsdale Road,
National Technology Park
Limerick / Ireland

Tel: +353.61.33.22.33

Fax: +353.61.33.25.84

UNITED KINGDOM

Intepro Systems
1 Lakeside Business Park
Swan Lane, Sandhurst
Berkshire GU47 9DN / UK

Tel/Fax: +44.1252.875.600

CHINA

No.2405, Block D
Shahe Century Holiday Plaza
Nanshan District
Shenzhen, China 518053

Tel: +86 755 86398564

Fax: +86 755 86398567