

## TGA Dual Load

## TGA 706-0005

- **Electronic loads, up to 300 Watts**
- **Plug in module for TGA Architecture<sup>1</sup>**
- **Constant current and resistance modes**
- **Each load independently isolated ( optically)**
- **On board selftest circuitry<sup>2</sup>**
- **Backdrive and current measurement relays on-board**
- **High speed operation, less than 25uSec loop response**

The TGA dual load module is ideal for providing modular load capability in any automatic test system. Each load is fully featured and provides 150Watts of isolated load sink capability, a total of 300Watts per module.

Multiple modules can be configured in parallel to facilitate higher power outputs. Each TGA rack can accommodate up to 9 load modules (2.7Kwatts per rack) and multiple racks can be configured in a system. This makes the Intepro TGA load system one of the most cost effective and modular load facilities available on the market today.

Each load is fully programmable with twelve (12) bit resolution. In addition each load has two ranges to improve overall program accuracy.

Each load can operate in constant current, constant power and constant resistance mode. The load may also be modulated (pulsed) by an external signal source using the on board pulse relays. Each load also has built in relays to facilitate easy O.V.P. (backdrive) testing in a power supply test system.

Each load is also electronically protected from Over Power, Over Current and Over Temperature. This is a key feature to ensure reliable operation in the harsh environments of power supply testing.

All calibration of the module is achieved via software routines. There are no potentiometers on the module. The calibration constants for the module are stored in EEPROM on the module and therefore travel with each circuit. This can significantly reduce the time involved in calibrating a system with several loads installed.



The module also has a jumper selectable loop response time setting. The load can be operated at high speed in normal functional test systems. However, the loop response can be slowed down in applications such as Burnin where there may be very significant lead lengths in the fixture wiring to the units in Burnin. The inductance associated with long wire lengths could cause the load to oscillate if the loop response was too fast.

The module is fully supported by the POWERSUITE and POWERSTAR software platforms supplied by Intepro.

The module is designed for simple plug in insertion into a TGA backplane system ( low cost ).

User connection to the module is via Positronic 7W2 female connectors. This facilitates high power and signal connection in one easy to remove connector.

Due to the rather poor power dissipation capability of a VXI mainframe it is not practical to install the TGA dual load directly into a VXI rack. However, a Intepro VXI commander card may be installed in a VXI rack which can then be used to drive all external TGA racks from a VXI bus. This effectively makes the TGA loads look like VXI message based instruments to the software but also makes use of the high power dissipation capability of the TGA racks.

The TGA dual load is ideal for high specification, medium power, load requirements in an ATE system.

Technical Specifications		Range	Resolution	Accuracy
Constant Current	Range 1	0A to 7.5A	2mA	+/- (0.25 % setting + resolution + 3mA)
	Range 2	0A to 30A	8mA	+/- (0.25 % setting + resolution + 3mA)
Constant Resistance	Range 1	0.0667R to 0.667R	0.004*Vin	+/- (0.5% setting <sup>3</sup> + (0.01*vin +5mA))
	Range 2	0.667R to 2730R	0.0004*Vin	+/- (0.5% setting + (0.001*vin +5mA))

<sup>3</sup> expected current

<b>Power Rating :</b>	150 Watts max (per load)	<b>Operating Temp :</b>	0°C to 55°C
<b>Response time :</b>	20uSec (min) - 200uSec (max) (jumper selectable)	<b>Storage temp :</b>	0°C to 70°C
<b>Measure accuracy :</b>	0.25 % of actual current+3mA	<b>Humidity :</b>	10% to 85% Relative
<b>Input voltage range :</b>	0.5V to 100V DC (* Higher voltages available, contact factory)		

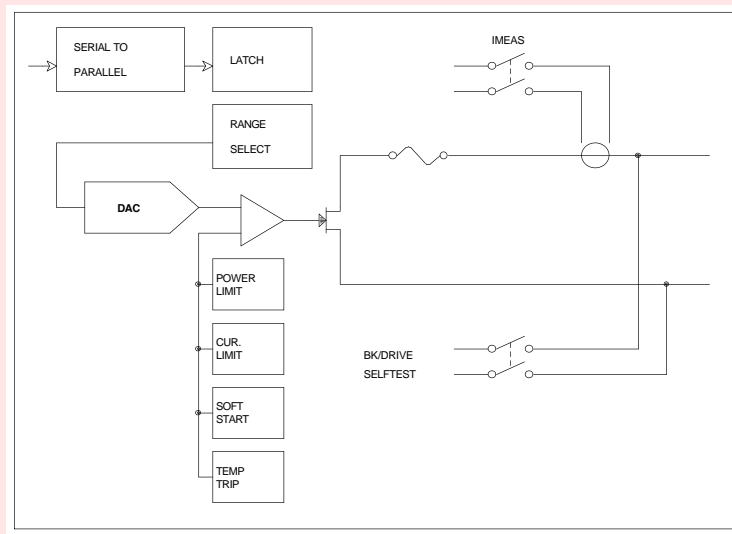

**Ordering information**  
706-0005 TGA Dual Load Module

**Options**

<sup>1</sup> see separate data sheet on TGA backplane

<sup>2</sup> Selftest software available as a separate



**Intepro Systems**  
1530 S. Lyon Street  
Santa Ana, CA 92705  
+1.714.679.9749  
+1.714.835.3441 (Fax)

**EU/Ireland**  
Intepro Systems  
Lonsdale Road  
National Technology Park  
Limerick / Ireland  
+353.61.33.22.33  
+353.61.33.25.84 (Fax)

**UK**  
Intepro Systems  
Ashville Way  
Molly Millar's Lane  
Wokingham / UK  
+44.118.977.0070  
+44.118.979.2969 (Fax)