

PSI 9000 2U Series

1000 W to 3000 W

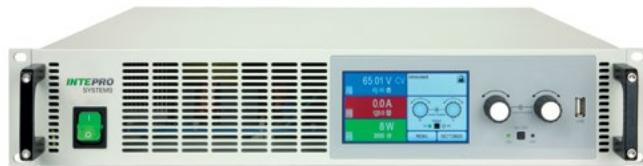

Programmable
DC Power
Supplies

INTEPRO
SYSTEMS

THE POWER TEST EXPERTS

PSI 9000 2U Series

1000 W to 3000 W



Product Overview

The PSI 9000 Series of high performance programmable DC power sources are FPGA controlled and come standard with several advanced features. User-friendly, interactive menu navigation makes the use of this equipment remarkably easy to program.



PSI 9000 2U

User and process profiles can be edited, saved and archived so that the reproducibility of a test or other application is improved.

A single 2U chassis houses up to 3kW of DC power and can be paralleled up to 30kW. Each chassis features a controller which allows the flexibility of separating into individual sources or paralleling for high power applications.

Power

All models feature a flexible Auto-Ranging output stage which provides higher output current at reduced voltages so the source maintains maximum output power across a wide range of voltage operation.

Traditional DC sources offer a square operation curve meaning the source maintains maximum rated current at less than full scale voltage. A traditional 3kW DC source with a voltage range of 600V provides 5A. At 250V the source still offers 5A so only 625W is actually delivered to the unit under test.

Auto-Ranging addresses this issue by automatically increasing the output current at reduced voltages. Take the PS 9750-12 which is 3kW as an example. At 600V the source offers 5A. At 250V the source provides 12A which means the source maintains a 3kW output rating.

Auto-Range is especially useful when testing products that require varied input voltages while maintaining regulated output power. This feature often results in a single chassis solutions versus buying multiple sources to address low and high voltage / current requirements.

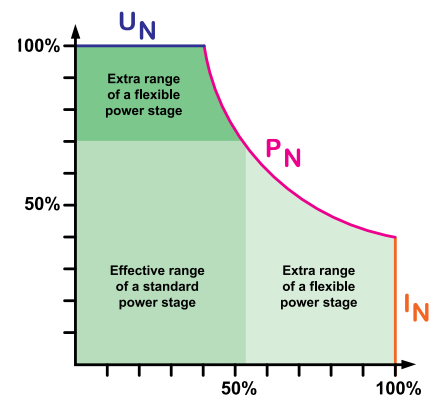

Featured Benefits

- High efficiency up to 93%
- Flexible, power regulated output stage
- Various protection circuits (OVP, OCP, OPP, OTP)
- Intuitive TFT touch panel with display for values, status and notifications
- Integrated true function generator
- Remote sensing with automatic detection
- Galvanically isolated, analog interface with:
- U / I / P programmable via 0...10 V or 0...5 V
- U / I monitoring via 0...10 V or 0...5 V
- Photovoltaic array simulation
- Internal resistance simulation and regulation
- Temperature controlled fans for cooling
- Fuel cell simulation
- SCPI command language supported

Protective Features

For protection of the equipment connected, it is possible to set an overvoltage protection threshold (OVP), as well as one for overcurrent (OCP) and overpower (OPP).

As soon as one of these thresholds is reached for any reason, the DC output will be immediately shut off and a status signal will be generated on the display and via the interfaces.

There is furthermore an overtemperature protection, which will shut off the DC output if the device overheats.

Remote Sensing

The standard sensing input can be connected directly to the load in order to compensate voltage drops along the power cables up to a certain level. If the sensing input is connected to the load, the power supply will adjust the output voltage automatically to make ensure the accurate required voltage is available at the load.

Display & Controls

Set values and actual values of output voltage, output current and output power are clearly represented on the graphic display. The LCD display is touch sensitive and can be intuitively used to control all functions of the device with just a finger.

Set values of voltage, current, power or resistance (internal resistance simulation) can be adjusted using the rotary knobs or entered directly via a numeric pad.

To prevent unintentional operations, all operation controls can be locked.

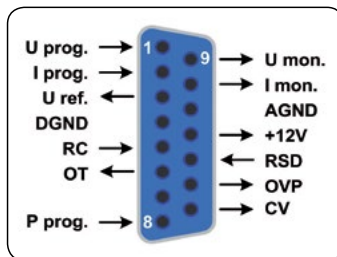

Analog Interface

There is a galvanically isolated analog interface terminal, located on the rear of the device. It offers analog inputs to set voltage, current and power from 0...100% through control voltages of 0 V...10 V or 0 V...5 V.

To monitor the output voltage and current, there are analog outputs with voltage ranges of 0 V...10 V or 0 V...5 V. Also, several inputs and outputs are available for controlling and monitoring the device status.

Display and Control Panel

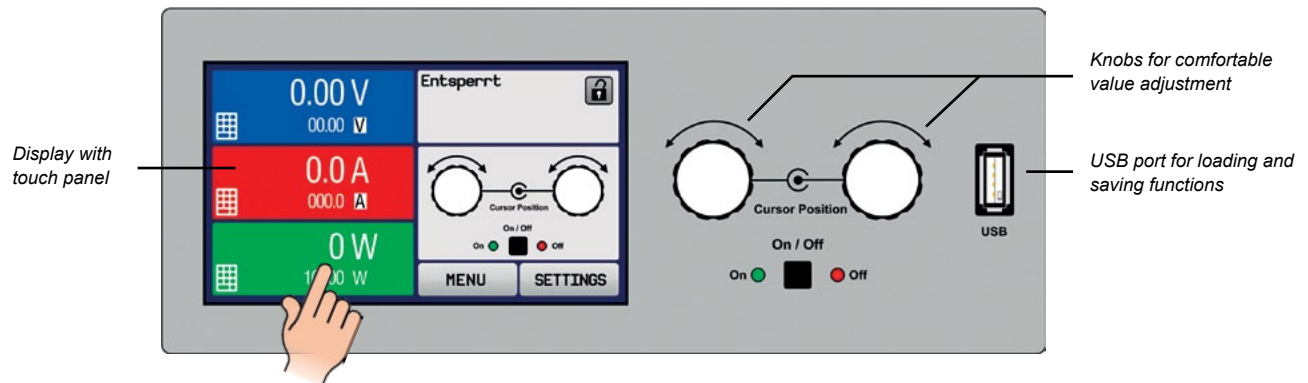

Function Generator

All models within this series is based on 4096 data points and generates typical functions, as displayed in the figures below, and applies them to either the output voltage or the output current. The generator can be completely configured and controlled by using the touch panel on the front of the device, or by remote control via one of the digital interfaces.

The predefined functions offer all necessary parameters to the user, such as Y offset, time / frequency or amplitude, for full configuration ability.

Additionally to the standard functions, which are all based upon a so-called arbitrary generator, this base generator is accessible for the creation and execution of complex sets of functions, separated into up to 100 sequences. Those can be used for testing purposes in development and production.

The sequences can be loaded from and saved to a standard USB flash drive via the USB port on the front panel, making it easy to change between different test sequences.

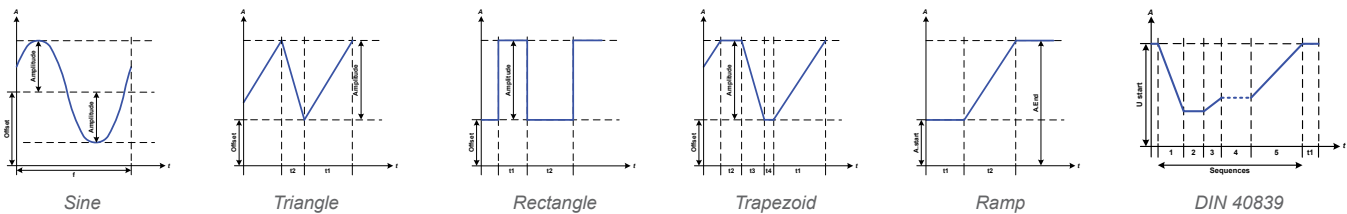

The figure below shows a fictional example of a complex function of 40 sequences, as it can be realized with the arbitrary generator. The function can be created on the device or externally and then loaded or saved:

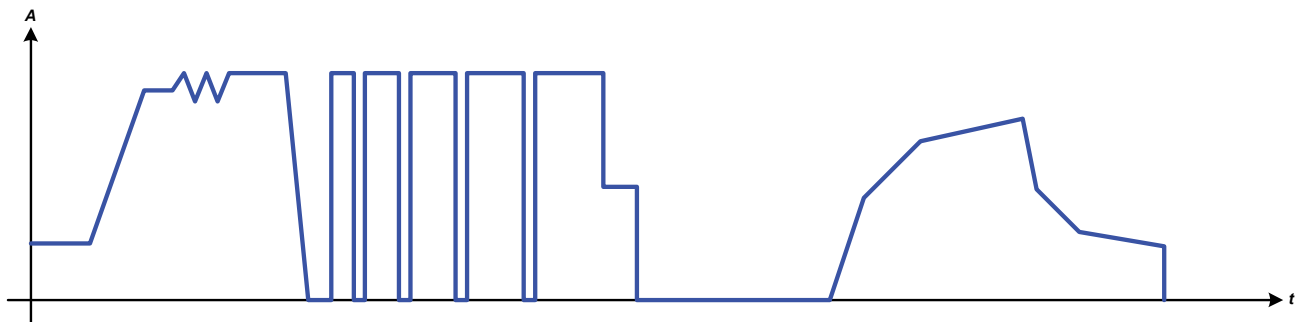

There is furthermore a XY generator, which is used to generate other functions like UI or IU, which are defined by the user in form of tables (CSV file) and then loaded from USB drive.

Photovoltaic Solar Array Simulation

The PSI is an ideal solution for simulating static or dynamic irradiance levels of solar array. The high accuracy irradiance curve is based on 16,400 data points and adjustable in 1% increments. Isc, Uoc, MPP and Imp are user programmable.

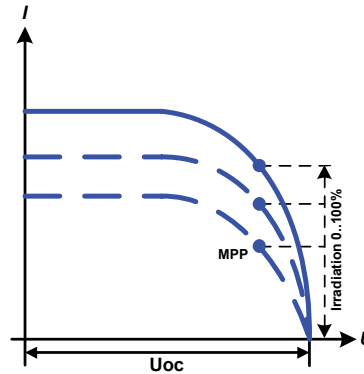
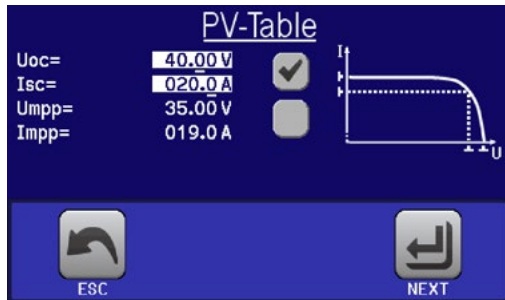

Fuel Cell Simulation

An embedded Fuel Cell table function is used to simulate the characteristics of voltage and current of a fuel cell. Simply define slope points and the data is automatically calculated then transferred to the function generator and output from the DC source.

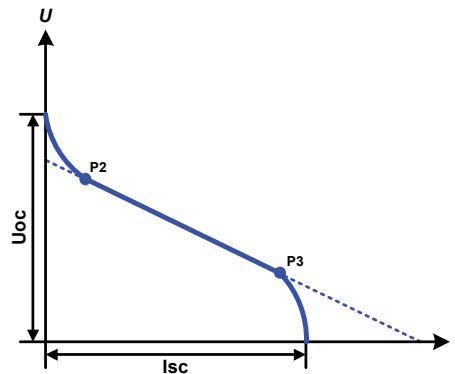
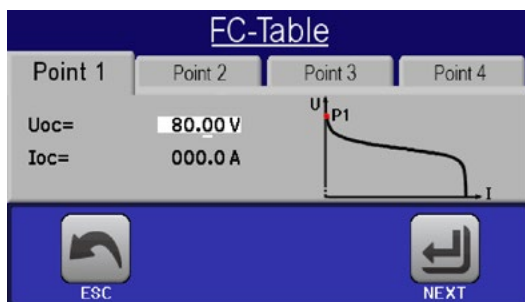

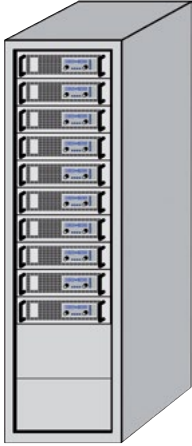

Parallel for High Power

Chassis can be paralalled up to 30kW. Intepro offers turn-key integrated solutions in chassis up to 42U and allow installation of auxiliary equipment such as DC loads, DMM's and oscilloscope. Contact Intepro with your system configuration requirements.

Supervision Features

All models offer supervision features for voltage and current steps. The supervision is configurable to monitor voltage or current over- and undershooting. As a reaction, the device can generate a notification of selectable type:

- Signals are displayed only; even if the fault is still active, without affecting the output.
- Warnings remain active and must be acknowledged after the fault is removed.
- Alarms will shut off the output instantly and can also be signaled acoustically.

Programmable Impedance

Alnternal resistance control provides a means to virtually simulate an internal resistance which is in series to the voltage source and thus also in series to the load. According to Ohm's Law, this causes an voltage drop, which will result in a difference between adjusted output voltage and the actual output voltage.

The adjustable resistance range is generally defined between 0 and 30 * UNOM / INOM of the particular model. The voltage setting in dependency of the resistance set value and the output current is done by calculation of the microcontroller and thus will be significantly slower the other controllers inside the control circuit.

U//P Operation

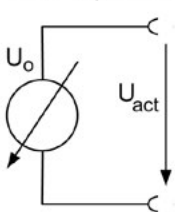

U//R Operation

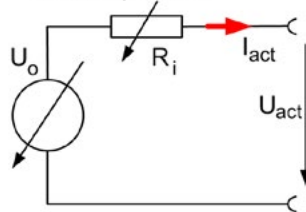

$$U_{Set} = U_0 - I_{Act} * R_{Set} \quad \left| \begin{matrix} P_{Set}, I_{Set} \end{matrix} \right.$$

Options

- Digital interface modules for RS232, CANopen, Modbus TCP, Profibus, Profinet/IO, Devicenet or Ethernet. The interface slot is located on the rear panel (standard models only), making it easy for the user to plug in a new interface or to replace an existing one. The interface will be automatically detected by the device and requires no or only little configuration.
- Three-way interface (3W) with a rigid GPIB port installed instead of the default slot for retrofittable interface modules.
- High Speed ramping*
- Water Cooling **
- High Speed Ramping increases voltage slew rates by as much as 20x. Contact Intepro for details.

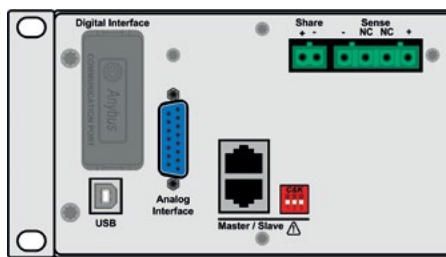

Rear connectors of the standard models

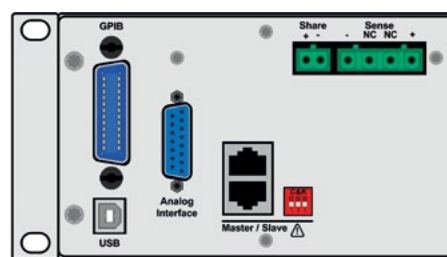

Rear connectors of models with option 3W

* Not available for all voltages - please quote for availability

** Generally available for models up to 200 V, for other models upon request

Technical Data	Series PSI 9000 2U	
Input AC		
- Voltage	100...264 V, 1ph+N (Models 1000W, 1500 W), 180...264 V, 1ph+N (Models 3000 W), 180...265 V, 2ph+N (Models 3000W)	
- Frequency	45...66 Hz	
- Power factor	>0.99	
Output voltage DC		
- Accuracy	<0.1%	
- Load regulation 0-100%	<0.05%	
- Line regulation $\pm 10\% \Delta U_{AC}$	<0.02%	
- Regulation 10-100% load	<2 ms	
- Rise time 10-90%	Max. 30 ms (Standard models) Max. 2ms (High speed versions, see table below)	
- Overvoltage protection	Adjustable, 0...110% U_{Nom}	
Output current		
- Accuracy	<0.2%	
- Load regulation 0-100% ΔU_{DC}	<0.15%	
- Line regulation $\pm 10\% \Delta U_{AC}$	<0.05%	
Output power		
- Accuracy	<1%	
Overvoltage category	2	
Protection	OTP, OVP, OCP, OPP, PF	
Isolation		
- Input to enclosure	2500 V DC	
- Input to output	2500 V DC	
- Output to enclosure (PE)	Negative: max. 400 V DC, positive: max. 400 V DC + output voltage	
Pollution degree	2	
Protection class	1	
Display and panel	Graphics display with touch panel	
Digital interfaces		
- Built-in	1x USB type B for communication 1x GPIB (optional with option 3W)	
- Slot	1x for retrofittable plug-in modules (standard models only)	
Analog interface	Built in, 15-pole D-Sub, female	
- Input range	0...5 V / or 0...10 V (switchable)	
- Accuracy U / I	0...10 V: <0.2%	0...5 V: <0.4%
- Programming resolution	See table below	
Series operation	Possible, with max. potential shift of 400 V against PE on any DC minus pole	
Parallel operation	Yes, with true master-slave, up to 10 units (via Share bus)	
Standards	EN 60950, EN 61326, EN 55022 Class B	
Cooling	Fan(s)	
Operation temperature	0...50 °C	
Storage temperature	-20...70 °C	
Humidity	<80%	
Operation altitude	<2000 m	
	1000 W / 1500 W	3000 W
Weight ⁽¹⁾	25.4lbs / 11.5kg	32.4lbs / 14.7kg
Dimensions (W H D) ⁽²⁾	19" 2 HE/U 465 mm	19" 2 HE/U 465 mm

(1) Standard version, models with options may vary

(2) Enclosure of the standard version and not overall size, versions with options may vary

Standard Models	Voltage	Current	Power	Efficiency	Ripple U max. ⁽²⁾	Ripple I max. ⁽²⁾	Programming ⁽¹⁾		
							U (typ.)	I (typ.)	P (typ.)
PSI 9040-40 2U	0...40 V	0...40 A	0...1000 W	≤92%	114 mV _{pp} / 8 mV _{RMS}	3.7 mA _{RMS}	0.8 mV	0.8 mA	
PSI 9080-40 2U	0...80 V	0...40 A	0...1000 W	≤92%	114 mV _{pp} / 8 mV _{RMS}	3.7 mA _{RMS}	1.5 mV	0.8 mA	
PSI 9200-15 2U	0...200 V	0...15 A	0...1000 W	≤93%	164 mV _{pp} / 34 mV _{RMS}	2.2 mA _{RMS}	4 mV	0.3 mA	
PSI 9360-10 2U	0...360 V	0...10 A	0...1000 W	≤93%	210 mV _{pp} / 59 mV _{RMS}	1.6 mA _{RMS}	7 mV	0.2 mA	
PSI 9500-06 2U	0...500 V	0...6 A	0...1000 W	≤93%	190 mV _{pp} / 48 mV _{RMS}	0.5 mA _{RMS}	10 mV	0.1 mA	
PSI 9750-04 2U	0...750 V	0...4 A	0...1000 W	≤93%	212 mV _{pp} / 60 mV _{RMS}	0.3 mA _{RMS}	15 mV	0.1 mA	
PSI 9040-60 2U	0...40 V	0...60 A	0...1500 W	≤92%	114 mV _{pp} / 8 mV _{RMS}	5.6 mA _{RMS}	0.8 mV	1.1 mA	
PSI 9080-60 2U	0...80 V	0...60 A	0...1500 W	≤92%	114 mV _{pp} / 8 mV _{RMS}	5.6 mA _{RMS}	1.5 mV	1.1 mA	
PSI 9200-25 2U	0...200 V	0...25 A	0...1500 W	≤93%	164 mV _{pp} / 34 mV _{RMS}	3.3 mA _{RMS}	4 mV	0.5 mA	
PSI 9360-15 2U	0...360 V	0...15 A	0...1500 W	≤93%	210 mV _{pp} / 59 mV _{RMS}	2.4 mA _{RMS}	7 mV	0.3 mA	
PSI 9500-10 2U	0...500 V	0...10 A	0...1500 W	≤93%	190 mV _{pp} / 48 mV _{RMS}	0.7 mA _{RMS}	10 mV	0.2 mA	
PSI 9750-06 2U	0...750 V	0...6 A	0...1500 W	≤93%	212 mV _{pp} / 60 mV _{RMS}	0.5 mA _{RMS}	15 mV	0.1 mA	
PSI 9040-120 2U	0...40 V	0...120 A	0...3000 W	≤92%	114 mV _{pp} / 8 mV _{RMS}	11 mA _{RMS}	0.8 mV	2.3 mA	
PSI 9080-120 2U	0...80 V	0...120 A	0...3000 W	≤92%	114 mV _{pp} / 8 mV _{RMS}	11 mA _{RMS}	1.5 mV	2.3 mA	
PSI 9200-50 2U	0...200 V	0...50 A	0...3000 W	≤93%	164 mV _{pp} / 34 mV _{RMS}	6.5 mA _{RMS}	4 mV	1 mA	
PSI 9360-30 2U	0...360 V	0...30 A	0...3000 W	≤93%	210 mV _{pp} / 59 mV _{RMS}	5 mA _{RMS}	7 mV	0.6 mA	
PSI 9500-20 2U	0...500 V	0...20 A	0...3000 W	≤93%	190 mV _{pp} / 48 mV _{RMS}	1.5 mA _{RMS}	10 mV	0.4 mA	
PSI 9750-12 2U	0...750 V	0...12 A	0...3000 W	≤93%	212 mV _{pp} / 60 mV _{RMS}	0.9 mA _{RMS}	15 mV	0.2 mA	

(1 Programmable resolution disregarding device errors

(2 RMS value: measures at LF with BWL 300 kHz, PP value: measured at HF with BWL 20MHz

(3 Ordering number of the standard version, models with option 3W installed have different ordering numbers

High Speed Models	Voltage	Current	Power	Ripple U max. ⁽²⁾	Output capacity	Times
						Fall
PSI 9040-40 2U HS	0...40 V	0...40 A	0...1000 W	114 mV _{pp} / 8 mV _{RMS}	86 µF	
PSI 9080-40 2U HS	0...80 V	0...40 A	0...1000 W	114 mV _{pp} / 8 mV _{RMS}	86 µF	
PSI 9200-15 2U HS	0...200 V	0...15 A	0...1000 W	164 mV _{pp} / 34 mV _{RMS}	40 µF	
PSI 9360-10 2U HS	0...360 V	0...10 A	0...1000 W	210 mV _{pp} / 59 mV _{RMS}	20 µF	
PSI 9500-06 2U HS	0...500 V	0...6 A	0...1000 W	190 mV _{pp} / 48 mV _{RMS}	15 µF	
PSI 9750-04 2U HS	0...750 V	0...4 A	0...1000 W	212 mV _{pp} / 60 mV _{RMS}	9 µF	
PSI 9040-60 2U HS	0...40 V	0...60 A	0...1500 W	114 mV _{pp} / 8 mV _{RMS}	86 µF	
PSI 9080-60 2U HS	0...80 V	0...60 A	0...1500 W	114 mV _{pp} / 8 mV _{RMS}	86 µF	
PSI 9200-25 2U HS	0...200 V	0...25 A	0...1500 W	164 mV _{pp} / 34 mV _{RMS}	40 µF	
PSI 9360-15 2U HS	0...360 V	0...15 A	0...1500 W	210 mV _{pp} / 59 mV _{RMS}	20 µF	
PSI 9500-10 2U HS	0...500 V	0...10 A	0...1500 W	190 mV _{pp} / 48 mV _{RMS}	15 µF	
PSI 9750-06 2U HS	0...750 V	0...6 A	0...1500 W	212 mV _{pp} / 60 mV _{RMS}	9 µF	
PSI 9040-120 2U HS	0...40 V	0...120 A	0...3000 W	114 mV _{pp} / 8 mV _{RMS}	172 µF	
PSI 9080-120 2U HS	0...80 V	0...120 A	0...3000 W	114 mV _{pp} / 8 mV _{RMS}	172 µF	
PSI 9200-50 2U HS	0...200 V	0...50 A	0...3000 W	164 mV _{pp} / 34 mV _{RMS}	80 µF	
PSI 9360-30 2U HS	0...360 V	0...30 A	0...3000 W	210 mV _{pp} / 59 mV _{RMS}	40 µF	
PSI 9500-20 2U HS	0...500 V	0...20 A	0...3000 W	190 mV _{pp} / 48 mV _{RMS}	30 µF	
PSI 9750-12 2U HS	0...750 V	0...12 A	0...3000 W	212 mV _{pp} / 60 mV _{RMS}	18 µF	

(1 Programmable resolution without device error

(2 RMS value: measures at LF with BWL 300 kHz, PP value: measured at HF with BWL 20MHz

(3 Ordering number of the HS base version, models with option 3W installed have different ordering numbers

Note: the models only differ from the standard models regarding output capacity, voltage controller speed and voltage dynamics.

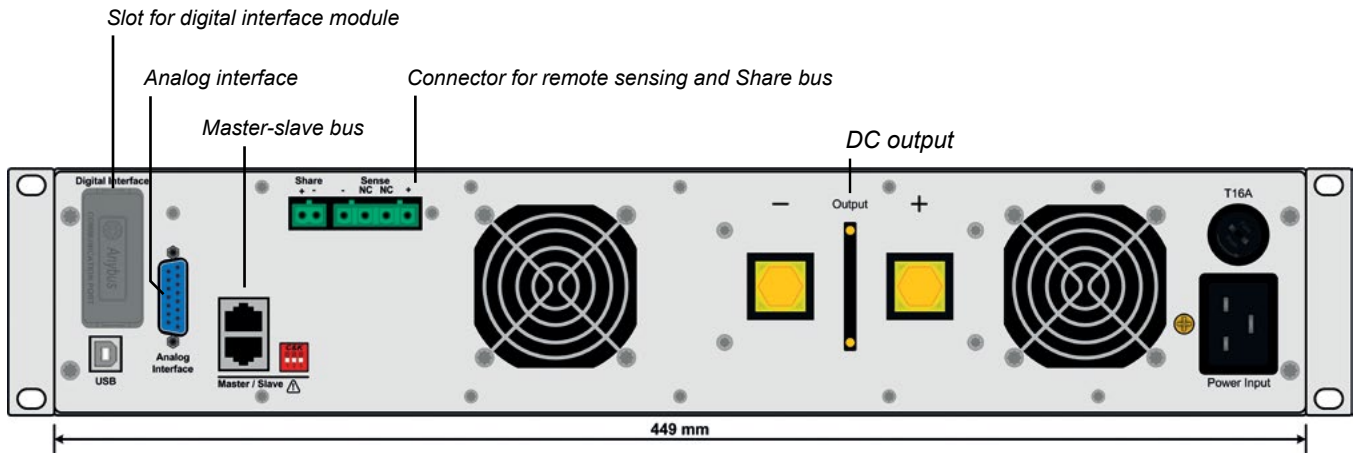
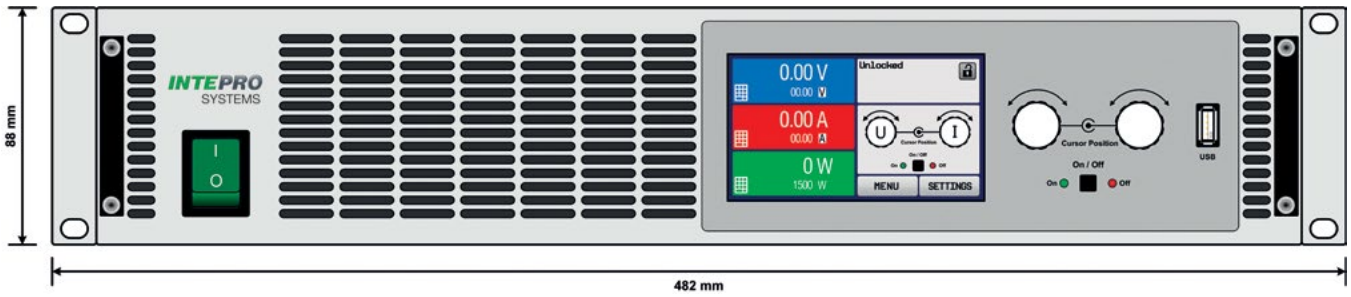

Rear view of base model

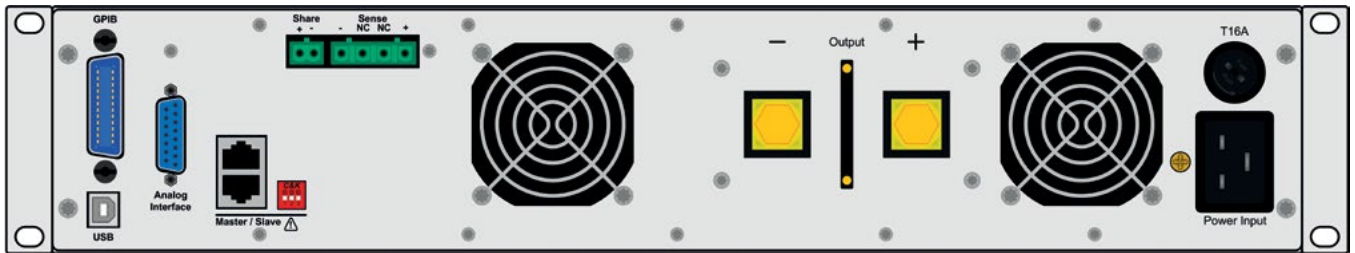

Rear view with option 3W

Contact Us

United States

Intepro Systems America, LP
14712-A Franklin Ave
Tustin, CA 92780
Tel: 1 714 953 2686
sales@inteproate.com
www.inteproate.com

United Kingdom

Intepro UK Ltd.
9 Lakeside Business Park
Swan Lane, Sandhurst Berkshire
GU47 9DN / UK
Tel: 44 012 5287 5600

China

Intepro Power Electronics
(Shenzhen) Co., Ltd
No. 828, Block 7,
Fourth Industrial Area
Nanyou, Nashan District
Shenzhen, China 518052
Tel: 0086 755 86500020